

CROSSMAN[®]

PROFESSIONAL



CONTENTS

4 Socket Sets

25 Hand Sockets

60 Impact Sockets



76 Wrenches



95 Hex Key Wrenches



102 Screwdrivers

119 Fastener Drive Tools



136 Hand Tools



162 Files

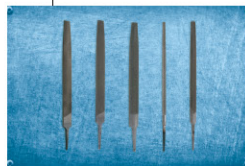

167 Hole Saws



170 Pneumatic Tools



189 Diamond Tip



SOCKET SETS



P5 1/4" Socket Sets

P8 3/8" Socket Sets

P12 1/2" Socket Sets

P22 3/4" Socket Sets

1/4" Socket Sets



1/4" Drive E-Socket Set - 6 Pcs.		
Item No.		kgs
87-041	12/72	1.2/8.2
<ul style="list-style-type: none"> 6 Pcs. E-Sockets: E4, E5, E6, E7, E8, E10. 		



1/4" Drive Metric Socket Set - 14 Pcs.		
Item No.		kgs
87-042	12/72	3.12/19.72
<ul style="list-style-type: none"> 14 Pcs. Sockets (Metric, 6-Point): 3.5, 4, 4.5, 5, 5.5, 6, 7, 8, 9, 10, 11, 12, 13, 14 mm. 		



1/4" Drive Metric Socket Set - 15 Pcs.		
Item No.		kgs
87-043	12/72	4.08/25.48
<ul style="list-style-type: none"> 14 Pcs. Sockets (Metric, 6-Point): 3.5, 4, 4.5, 5, 5.5, 6, 7, 8, 9, 10, 11, 12, 13, 14 mm. 1 Pc. 4-1/2" Sliding "T" Bar. 		



1/4" Bit Socket Set - 10 Pcs.		
Item No.		kgs
87-044	6/48	1.8/14.8
<ul style="list-style-type: none"> 3 Pcs. Phillips Bit Sockets: PH1, PH2, PH3 3 Pcs. Slotted Bit Sockets: 4.0, 5.5, 6.5 mm. 3 Pcs. POZIDRIV[®] Bit Sockets: PZ1, PZ2, PZ3. 1 Pc. 6" Spinner. 		



1/4" Hex Bit Socket Set - 8 Pcs.		
Item No.		kgs
87-045	6/48	1.6/13.5
<ul style="list-style-type: none"> 7 Pcs. Hex Bit Sockets: 3, 4, 5, 5.5, 6, 7, 8 mm. 1 Pc. 4-1/2" Sliding "T" Bar. 		



1/4" TORX [®] Tamper Proof Bit Socket Set - 8 Pcs.		
Item No.		kgs
87-046	6/48	1.5/12.5
<ul style="list-style-type: none"> 7 Pcs. TORX[®] Tamper Proof Bit Sockets: T10, T15, T20, T25, T27, T30, T40. 1 Pc. 4-1/2" Sliding "T" Bar. 		

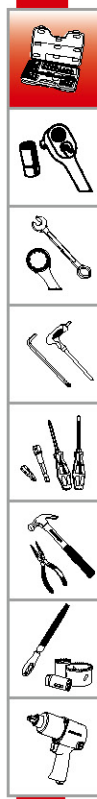

1/4" Socket Sets



1/4" Drive SAE Socket Set - 16 Pcs.

Item No.		kgs
99-081	1/20	0.8/17.3

- 10 Pcs. Sockets (SAE, 6-Point):
5/32", 3/16", 7/32", 1/4", 9/32", 5/16", 11/32", 3/8", 7/16", 1/2".
- 1 Pc. 6" Ratchet (Round Head).
- 2 Pcs. 3" & 6" Extension.
- 1 Pc. 4-1/2" Sliding "T" Bar.
- 1 Pc. 6" Flex Handle.
- 1 Pc. 1-5/16" Universal Joint.

▲ Blow Mold Box



1/4" Drive Metric Socket Set - 17 Pcs.

Item No.		kgs
99-080	1/20	0.8/17.3

- 11 Pcs. Sockets (Metric, 6-Point):
4, 5, 5.5, 6, 7, 8, 9, 10, 11, 12, 13 mm.
- 1 Pc. 6" Ratchet (Round Head).
- 2 Pcs. 3" & 6" Extension.
- 1 Pc. 4-1/2" Sliding "T" Bar.
- 1 Pc. 6" Flex Handle.
- 1 Pc. 1-5/16" Universal Joint.

▲ Blow Mold Box



1/4" Drive Metric & SAE Socket Set - 24 Pcs.

Item No.		kgs
99-024	1/24	1.6/23.4

- 10 Pcs. Sockets (Metric, 6-Point):
4, 5, 6, 7, 8, 9, 10, 11, 12, 13 mm.
- 9 Pcs. Sockets (SAE, 6-Point):
3/16", 7/32", 1/4", 9/32", 5/16", 11/32", 3/8", 7/16", 1/2".
- 1 Pc. 6" Quick Release Ratchet (Compact Pear Head w/Steel Handle).
- 1 Pc. 6" Flex Handle.
- 2 Pcs. 2" & 6" Extensions.
- 1 Pc. 1-5/16" Universal Joint.

▲ Metal Box



1/4" Drive Metric Socket Set - 32 Pcs.

Item No.		kgs
87-048	1/6	1.4/9.4

- 14 Pcs. Sockets (Metric, 6-Point):
3.5, 4, 4.5, 5, 5.5, 6, 7, 8, 9, 10, 11, 12, 13, 14 mm.
- 7 Pcs. Deep Sockets (Metric, 6-Point):
6, 8, 10, 11, 12, 13, 14 mm.
- 6 Pcs. E- Sockets: E4, E5, E6, E7, E8, E10.
- 1 Pc. 1-5/16" Universal Joint.
- 1 Pc. 4-1/2" Sliding "T" Bar.
- 1 Pc. 6" Quick Release Ratchet(45 Teeth).
- 2 Pcs. 2" & 4" Extension.

▲ Blow Mold Box



1/4" Socket Sets

1/4" & 3/8" Drive Socket Set - 38 Pcs.



Item No.		 kgs
99-028	1/4	2.8/12.2

- 14 Pcs. Sockets (1/4" Dr., 6-Point):
4, 5, 6, 7, 8, 9, 10 mm &
3/16", 7/32", 1/4", 9/32", 5/16", 11/32", 3/8".
- 15 Pcs. Sockets (3/8" Dr., 12-Point):
10, 11, 12, 13, 14, 15, 17, 19 mm &
3/8", 7/16", 1/2", 9/16", 5/8", 11/16", 3/4".
- 1 Pc. 1/4" Dr. - 6" Spinner.
- 1 Pc. 3/8" Dr. - 2" Universal Joint.
- 2 Pcs. 3/8" Dr. - 16mm (5/8") & 21mm (13/16") Spark Plug Socket.
- 1 Pc. 3/8" Dr. - 8" Quick Release Ratchet (Pear Head).
- 2 Pcs. 3/8" Dr. - 3" & 6" Extension.
- 1 Pc. 3/8" Dr. - 8" Flex Handle.
- 1 Pc. 3/8" Dr. - 3/8" F x 1/4"M Adapter.

▲ Blow Mold Box

1/4" & 3/8" Drive Socket Set - 42 Pcs.



Item No.		 kgs
99-091	1/4	2.2/10.7

- 16 Pcs. Sockets (3/8" Dr., 6-Point):
9, 10, 11, 12, 13, 14, 15, 17, 19 mm &
3/8", 7/16", 1/2", 9/16", 5/8", 11/16", 3/4".
- 19 Pcs. Sockets (1/4" Dr., 6-Point):
4.5, 5, 5.5, 6, 7, 8, 9, 10, 11, 12 mm &
3/16", 7/32", 1/4", 9/32", 5/16", 11/32", 3/8", 7/16", 1/2".
- 1 Pc. 3/8" Dr. - 3/8" F x 1/4"M Adapter.
- 2 Pcs. 3/8" Dr. - 16mm (5/8") & 21mm (13/16") Spark Plug Socket.
- 1 Pc. 3/8" Dr. - 3" Extension.
- 1 Pc. 1/4" Dr. - 6" Spinner.
- 1 Pc. 3/8" Dr. - 8" Ratchet (Round Head).

▲ Blow Mold Box

1/4" Drive Metric Socket Set - 42 Pcs.



Item No.		 kgs
87-047	1/6	2/12

- 14 Pcs. Sockets (Metric, 6-Point):
3.5, 4, 4.5, 5, 5.5, 6, 7, 8, 9, 10, 11, 12, 13, 14 mm.
- 6 Pcs. Hex Bit Sockets: 3, 4, 5, 6, 7, 8 mm.
- 7 Pcs. TORX[®] Tamper Proof Bit Sockets:
T10, T15, T20, T25, T27, T30, T40.
- 3 Pcs. POZIDRIV[®] Bit Sockets: PZ1, PZ2, PZ3.
- 3 Pcs. Phillips Bit Sockets: PH1, PH2, PH3.
- 3 Pcs. Slotted Bit Sockets: 4, 5.5, 6.5 mm.
- 1 Pc. 6" (45 Teeth) Quick Release Ratchet.
- 1 Pc. 6" Spinner.
- 1 Pc. 1-5/16" Universal Joint.
- 1 Pc. 4-1/2" Sliding "T" Bar.
- 2 Pcs. 2" & 4" Extension.

▲ Blow Mold Box



3/8" Socket Sets

3/8" Drive Metric Socket Set - 14 Pcs.



Item No.		 kgs
87-052	6/24	5.28/22.12

- 13 Pcs. Sockets (Metric, 6-Point):
6, 8, 10, 11, 12, 13, 14, 16, 17, 19, 21, 22, 24 mm.
- 1 Pc. 8" Sliding "T" Bar.

3/8" Drive E-Socket Set - 8 Pcs.



Item No.		 kgs
87-053	12/72	4.08/25.48

- 8 Pcs. E-Sockets : E8, E10, E11, E12, E14, E16, E18, E20.

3/8" Drive Metric Socket Set - 13 Pcs.



Item No.		 kgs
87-054	12/24	7.92/16.84

- 13 Pcs. Sockets (Metric, 6-Point):
6, 8, 10, 11, 12, 13, 14, 16, 17, 19, 21, 22, 24 mm.

3/8" Drive TORX® Tamper Proof Bit Socket Set - 10 Pcs.



Item No.		 kgs
87-051	6/48	2.1/17

- 9 Pcs. TORX® Tamper Proof Bit Sockets:
T10, T15, T20, T27, T30, T40, T45, T50, T55.
- 1 Pc. 8" Sliding "T" Bar.

3/8" Drive Bit Socket Set - 12 Pcs.



Item No.		 kgs
87-055	4/24	3.6/23

- 3 Pcs. Phillips Bit Sockets: PH1, PH2, PH3.
- 4 Pcs. Slotted Bit Sockets: 4, 5, 6, 8 mm.
- 3 Pcs. POZIDRIV® Bit Sockets: PZ1, PZ2, PZ3.
- 1 Pc. 6" Quick Release Extension.
- 1 Pc. 8" Quick Release Sliding "T" Bar.

3/8" Drive Metric Hex Bit Socket Set - 10 Pcs.



Item No.		 kgs
87-057	4/24	3.2/20

- 9 Pcs. Hex Bit Sockets: 3, 4, 5, 6, 7, 8, 10, 12, 14 mm.
- 1 Pc. 8" Quick Release Sliding "T" Bar.



3/8" Socket Sets

3/8" Drive Metric Socket Set - 9 Pcs.



Item No.		kgs
99-094	1/20	1.0/21.0

- 5 Pcs. Sockets (Metric, 6-Point):
10, 12, 14, 17, 19 mm.
- 2 Pcs. 16mm (5/8") & 21mm (13/16") Spark Plug Socket.
- 1 Pc. 8" Ratchet (Round Head).
- 1 Pc. 6" Extension.

▲ Nylon Zipper Pouch

120 in 1 3/8" Drive Metric Socket Set - 19 Pcs.



Item No.		kgs
99-065	1/10	1.7/17.5

- 9 Pcs. Sockets (Metric, 6-Point):
8, 10, 11, 12, 13, 14, 15, 17, 19 mm.
- 5 Pcs. Deep Sockets (Metric, 6 Point):
8, 10, 12, 13, 14 mm.
- 1 Pc. 2" Universal Joint.
- 2 Pcs. 6" & 10" Quick Release Extension.
- 1 Pc. 8" Quick Release Sliding "T" Bar.
- 1 Pc. 16mm (5/8") Spark Plug Socket - Magnetic.

▲ Nylon Zipper Pouch

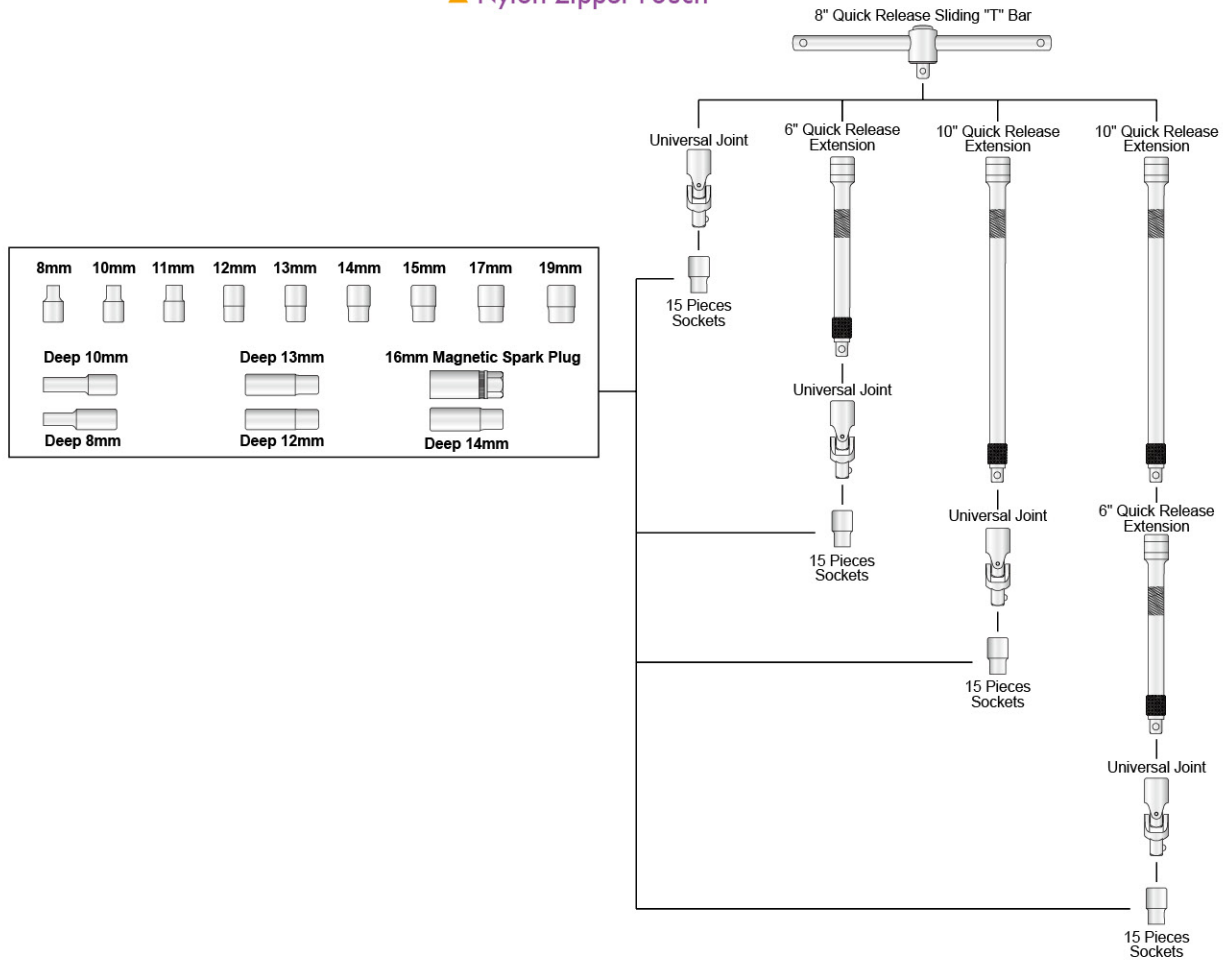

3/8" Socket Sets

3/8" Drive Metric Socket Set - 32 Pcs.



Item No.		 kgs
99-092 (6-Point)	1/4	3.3/14.4
99-032 (12-Point)	1/4	3.3/14.4

- 16 Pcs. Sockets (Metric):
8, 9, 10, 11, 12, 13, 14, 15, 16, 17, 18, 19, 20, 21, 22, 24 mm.
- 9 Pcs. Deep Sockets (Metric):
8, 10, 11, 12, 13, 14, 15, 17, 19 mm.
- 2 Pcs. 16mm (5/8") & 21mm (13/16") Spark Plug Socket.
- 1 Pc. 8" Ratchet (Round Head).
- 2 Pcs. 3" & 10" Extension.
- 1 Pc. 1/2"F x 3/8"M 3-Function Adapter.
- 1 Pc. 2" Universal Joint.

▲ Blow Mold Box

3/8" Drive SAE Socket Set - 32 Pcs.



Item No.		 kgs
99-089	1/4	3.3/14.4

- 16 Pcs. Sockets (SAE, 6-Point):
1/4", 5/16", 11/32", 3/8", 7/16", 15/32", 1/2", 9/16", 19/32",
5/8", 11/16", 3/4", 25/32", 13/16", 7/8", 15/16".
- 9 Pcs. Deep Sockets (SAE, 6-Point):
1/4", 5/16", 3/8", 7/16", 1/2", 9/16", 5/8", 11/16", 3/4".
- 2 Pcs. 16mm (5/8") & 21mm (13/16") Spark Plug Socket.
- 1 Pc. 8" Ratchet (Round Head).
- 2 Pcs. 3" & 10" Extension.
- 1 Pc. 1/2"F x 3/8"M 3-Function Adapter.
- 1 Pc. 2" Universal Joint.

▲ Blow Mold Box



3/8" Socket Sets

3/8" Drive Socket Set - 122 Pcs.

Item No.	 	 kgs
87-058	1/4	5.8/24.2



- 19 Pcs. Sockets (Metric, 6-Point):
6, 7, 8, 9, 10, 11, 12, 13, 14, 15, 16, 17, 18, 19, 20, 21, 22, 23, 24 mm.
- 11 Pcs. Sockets (SAE, 12-Point):
1/4", 5/16", 3/8", 7/16", 1/2", 9/16", 5/8", 11/16", 3/4", 13/16", 7/8".
- 8 Pcs. Deep Sockets (Metric, 6-Point):
8, 10, 11, 12, 13, 14, 17, 19 mm.
- 8 Pcs. E-Sockets : E8, E10, E11, E12, E14, E16, E18, E20.
- 2 Pcs. 16mm (5/8") & 21mm (13/16") Spark Plug Sockets.
- 1 Pc. 8" (45Teeth) Quick Release Ratchet (Pear Head).
- 1 Pc. 2" Universal Joint.
- 1 Pc. 5/16" (8mm) Hex Quick Release Bit Holder.
- 2 Pcs. 6" & 10" Quick Release Extension.
- 1 Pc. 8" Sliding "T" Bar
- 28 Pcs. Insert Bits (8mm x 75mm L); **Ideal for pneumatic & power tool use.**
 - ⊕ TORX® Tamper Proof:
T10, T15, T20, T25, T27, T30, T40, T45, T50, T55.
 - ⊕ POZIDRIV®: PZ1, PZ2, PZ3, PZ4.
 - ⊖ Slotted: 4, 6, 8, 10 mm.
 - ⊕ Phillips: PH1, PH2, PH3, PH4.
 - ⊖ Hex: 4, 5, 6, 8, 10, 12 mm.
- 40 Pcs. Insert Bits (8mm x 30mm L); **Ideal for pneumatic & power tool use.**
 - ⊕ TORX® Tamper Proof:
T10, T15, T20, T25, T27, T30, T40, T45, T50, T55.
 - ⊖ Hex: 4, 5, 6, 8, 10, 12 mm.
 - ⊕ Phillips: PH1, PH2, PH3, PH4.
 - ⊕ POZIDRIV®: PZ1, PZ2, PZ3, PZ4.
 - ⊕ Reinforced TORX®: RM5, RM6, RM8, RM10, RM12.
 - ⊖ Spline: M5, M6, M7, M8, M9, M10, M12.
 - ⊖ Slotted: 4, 6, 8, 10 mm.

▲ Blow Mold Box

Up to **1,856** functions is allowed for multiple combinations & applications.

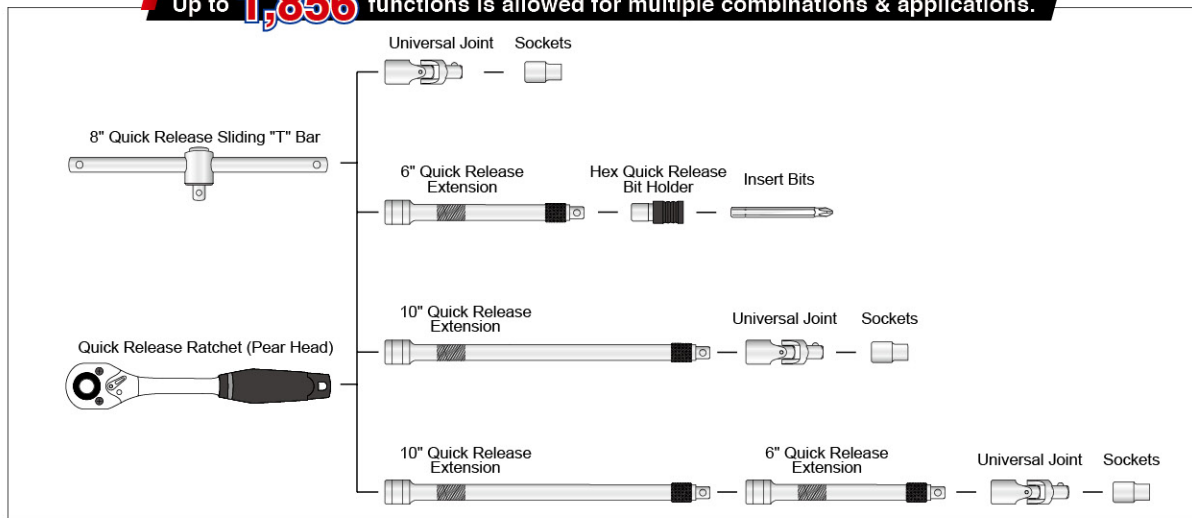

1/2" Socket Sets

1/2" Drive E-Socket Set - 9 Pcs.



Item No.		kgs
87-059	12/24	7.68/16.36

- 9 Pcs. E-Sockets: E10, E11, E12, E14, E16, E18, E20, E22, E24.

1/2" Drive Metric Socket Set - 9 Pcs.



Item No.		kgs
87-060	12/24	8.16/17.32

- 9 Pcs. Sockets (Metric, 6-Point):
10, 11, 12, 13, 14, 17, 19, 21, 24 mm.

1/2" Drive Metric Socket Set - 15 Pcs.



Item No.		kgs
87-066	6/12	9/19

- 14 Pcs. Sockets (Metric, 6-Point):
8, 10, 11, 12, 13, 14, 15, 16, 17, 18, 19, 21, 22, 24 mm.
- 1 Pc. 12" Sliding "T" Bar.

1/2" Drive Hex Bit Socket Set - 10 Pcs.



Item No.		kgs
87-061	6/12	7.8/15.7

- 9 Pcs. Hex Bit Sockets: 5, 6, 7, 8, 10, 12, 14, 17, 19 mm.
- 1 Pc. 12" Sliding "T" Bar.

1/2" Drive Bit Socket Set - 12 Pcs.



Item No.		kgs
87-062	6/12	10.2/20

- 3 Pcs. Phillips Bit Sockets: PH2, PH3, PH4.
- 4 Pcs. Slotted Bit Sockets: 8, 10, 12, 14 mm.
- 3 Pcs. POZIDRIV® Bit Sockets: PZ2, PZ3, PZ4.
- 1 Pc. 10" Quick Release Extension.
- 1 Pc. 10" Quick Release Sliding "T" Bar.

1/2" TORX® Tamper Proof Bit Socket Set - 10 Pcs.



Item No.		kgs
87-063	6/12	7.8/15.6

- 9 Pcs. TORX® Tamper Proof Bit Sockets:
T20, T25, T27, T30, T40, T45, T50, T55, T60.
- 1 Pc. 12" Sliding "T" Bar.



1/2" Socket Sets



1/2" Drive Metric Socket Set - 12 Pcs.

Item No.		 kgs
99-068	1/10	1.4/14.7

- 10 Pcs. Sockets (Metric, 6-Point):
8, 10, 11, 12, 13, 14, 15, 17, 19, 21 mm.
- 1 Pc. 10" 2-Way "L" Handle.
- 1 Pc. 1/2" F x 1/2" M 3-Function Adapter.

▲ Blow Mold Box



1/2" Drive Metric Socket Set - 11 Pcs.

Item No.		 kgs
99-090	1/20	1.2/24.1

- 11 Pcs. Sockets (Metric, 6-Point):
10, 11, 12, 13, 14, 15, 17, 19, 21, 24, 27 mm.

▲ Blow Mold Box



1/2" Drive Deep Metric Socket Set - 15 Pcs.

Item No.		 kgs
87-010	1/6	2.8/17.2

- 13 Pcs. Deep Sockets (Metric, 6-Point):
8, 10, 11, 12, 13, 14, 15, 16, 17, 19, 21, 22, 24 mm.
- 1 Pc. 10" Quick Release Ratchet (Pear Head).
- 1 Pc. Blow Mold Box.

▲ Blow Mold Box



1/2" Drive Metric Socket Set - 17 Pcs.

Item No.		 kgs
99-097 (6-Point)	1/6	3.4/21.3
87-008 (12-Point)	1/6	3.4/21.3

- 13 Pcs. Sockets (Metric):
8, 10, 11, 12, 13, 14, 15, 16, 17, 19, 21, 22, 24 mm.
- 1 Pc. 10" Quick Release Ratchet (Pear Head).
- 1 Pc. 5" Extension.
- 1 Pc. 15" Flex Handle.
- 1 Pc. Metal Box.

▲ Metal Box



1/2" Socket Sets

1/2" Drive Metric Socket Set - 17 Pcs.



Item No.		 kgs
99-057 W (6-Point)	1/6	3.1/19.2
99-047 W (12-Point)	1/6	3.1/19.2

- 13 Pcs. Sockets (Metric):
8, 10, 11, 12, 13, 14, 15, 17, 19, 20, 21, 22, 24 mm.
- 1 Pc. 10" Quick Release Ratchet (Round Head).
- 2 Pcs. 5" & 10" Extension.
- 1 Pc. 1/2" F x 1/2" M 3-Function Adapter.

▲ Metal Box

1/2" Drive Metric Socket Set - 18 Pcs.



Item No.		 kgs
99-096	1/6	3.7/22.7

- 13 Pcs. Sockets (Metric, 6-Point):
8, 10, 12, 13, 14, 15, 16, 17, 18, 19, 22, 24, 27 mm.
- 1 Pc. 10" Quick Release Ratchet (Round Head).
- 1 Pc. 2-7/8" Universal Joint.
- 1 Pc. 21mm (13/16") Spark Plug Socket.
- 1 Pc. 5" Extension.
- 1 Pc. 10" Sliding "T" Bar.

▲ Metal Box

1/2" Drive Metric Socket Set - 25 Pcs.



Item No.		 kgs
99-085 (6-Point)	1/4	4.1/21.3
87-007 (12-Point)	1/4	4.1/21.3

- 20 Pcs. Sockets (Metric):
8, 9, 10, 11, 12, 13, 14, 15, 16, 17, 18, 19, 20,
21, 22, 23, 24, 27, 30, 32 mm.
- 1 Pc. 10" Ratchet (Round Head).
- 2 Pcs. 5" & 10" Extension.
- 1 Pc. 10" Sliding "T" Bar.
- 1 Pc. 2-7/8" Universal Joint.

▲ Blow Mold Box



1/2" Socket Sets



1/2" Drive Metric Socket Set - 25 Pcs.

Item No.		 kgs
99-071 (6-Point)	1/4	4.2/21.6
99-031 (12-Point)	1/4	4.2/21.6

- 20 Pcs. Sockets (Metric):
8, 9, 10, 11, 12, 13, 14, 15, 16, 17, 18, 19, 20, 21, 22, 23, 24, 27, 30, 32 mm.
- 1 Pc. 10" Quick Release Ratchet (Pear Head).
- 2 Pcs. 5" & 10" Extension.
- 1 Pc. 10" Sliding "T" Bar.
- 1 Pc. 2-7/8" Universal Joint.

▲ Blow Mold Box



1/2" Drive Metric Socket Set - 25 Pcs.

Item No.		 kgs
99-095 (6-Point)	1/4	5.6/23.5
99-082 (12-Point)	1/4	5.6/23.5

- 18 Pcs. Sockets (Metric):
10, 11, 12, 13, 14, 15, 16, 17, 18, 19, 20, 21, 22, 23, 24, 27, 30, 32 mm.
- 1 Pc. 10" Quick Release Ratchet (Pear Head).
- 1 Pc. 21mm (13/16") Spark Plug Socket.
- 1 Pc. 2-7/8" Universal Joint.
- 1 Pc. 10" Sliding "T" Bar.
- 1 Pc. 17" Flex Handle.
- 2 Pcs. 5" & 10" Extension.

▲ Metal Box



1/2" Drive Metric Socket Set - 27 Pcs.

Item No.		 kgs
99-026 W (6-Point)	1/4	5.6/23.0
99-027 W (12-Point)	1/4	5.6/23.0

- 18 Pcs. Sockets (Metric):
10, 11, 12, 13, 14, 15, 16, 17, 18, 19, 20, 21, 22, 23, 24, 27, 30, 32 mm.
- 1 Pc. 10" Quick Release Ratchet (Pear Head).
- 2 Pcs. 5" & 10" Extension.
- 1 Pc. CRW10 - Helical Curved Jaw 10" Locking Pliers.
- 1 Pc. 16mm (5/8") Spark Plug Socket - Magnetic.
- 1 Pc. 15" Flex Handle.
- 1 Pc. 2-7/8" Universal Joint.
- 1 Pc. 3" Extension (with LED Light).
- 1 Set 3Pcs. 0% Hg Cell.

▲ Blow Mold Box



1/2" Socket Sets

1/2" Drive Metric Socket Set - 32 Pcs.



Item No.		kgs
99-093	1/4	4.5/23.0

- 19 Pcs. Sockets (Metric, 6-Point):
8, 9, 10, 11, 12, 13, 14, 15, 16, 17, 18, 19, 20, 21, 22, 24, 27, 30, 32 mm.
- 6 Pcs. Sockets (Metric, 12-Point):
10, 12, 14, 15, 17, 19 mm.
- 2 Pcs. 16mm (5/8") & 21mm (13/16") Spark Plug Socket.
- 1 Pc. 10" Ratchet (Round Head).
- 2 Pcs. 5" & 10" Extension.
- 1 Pc. 1/2" F x 1/2" M 3-Function Adapter.
- 1 Pc. 2-7/8" Universal Joint.

▲ Blow Mold Box

1/2" Drive SAE Socket Set - 32 Pcs.



Item No.		kgs
87-001	1/4	4.5/23.0

- 18 Pcs. Sockets (SAE, 6-Point):
5/16", 3/8", 7/16", 15/32", 1/2", 9/16", 19/32", 5/8", 11/16", 3/4", 25/32", 13/16", 7/8", 15/16", 1", 1-1/16", 1-1/8", 1-1/4".
- 7 Pcs. Sockets (SAE, 12-Point):
3/8", 7/16", 1/2", 9/16", 5/8", 11/16", 3/4".
- 2 Pcs. 16mm (5/8") & 21mm (13/16") Spark Plug Socket.
- 1 Pc. 10" Ratchet (Round Head).
- 2 Pcs. 5" & 10" Extension.
- 1 Pc. 1/2" F x 1/2" M 3-Function Adapter.
- 1 Pc. 2-7/8" Universal Joint.

▲ Blow Mold Box

1/2" Drive Metric Socket Set - 32 Pcs.



Item No.		kgs
87-009	1/4	4.5/23.0

- 19 Pcs. Sockets (Metric, 6-Point):
8, 9, 10, 11, 12, 13, 14, 15, 16, 17, 18, 19, 20, 21, 22, 24, 27, 30, 32 mm.
- 6 Pcs. Sockets (Metric, 12-Point):
10, 12, 14, 15, 17, 19 mm.
- 2 Pcs. 16mm (5/8") & 21mm (13/16") Spark Plug Socket.
- 1 Pc. 10" Quick Release Ratchet (Round Head).
- 2 Pcs. 5" & 10" Extension.
- 1 Pc. 1/2" F x 1/2" M 3-Function Adapter.
- 1 Pc. 2-7/8" Universal Joint.

▲ Blow Mold Box

1/2" Socket Sets



1/2" Drive Metric Socket Set - 32 Pcs.

Item No.		 kgs
99-099	1/4	4.5/23.0

- 19 Pcs. Sockets (Metric, 6-Point):
8, 9, 10, 11, 12, 13, 14, 15, 16, 17, 18, 19, 20,
21, 22, 24, 27, 30, 32 mm.
- 6 Pcs. Sockets (Metric, 12-Point):
10, 12, 14, 15, 17, 19 mm.
- 1 Pc. 10" Quick Release Ratchet (Pear Head).
- 2 Pcs. 5" & 10" Extension.
- 1 Pc. 1/2" F x 1/2"M 3-Function Adapter.
- 2 Pcs. 16mm (5/8") & 21mm (13/16") Spark Plug Socket.
- 1 Pc. 2-7/8" Universal Joint.

▲ Blow Mold Box



1/2" Drive Metric Socket Set - 32 Pcs.

Item No.		 kgs
99-023	1/4	4.5/23.0

- 19 Pcs. Sockets (Metric, 6-Point):
8, 9, 10, 11, 12, 13, 14, 15, 16, 17, 18, 19, 20,
21, 22, 24, 27, 30, 32 mm.
- 6 Pcs. Sockets (Metric, 12-Point):
10, 12, 14, 15, 17, 19 mm.
- 2 Pcs. 16mm (5/8") & 21mm (13/16") Spark Plug Socket.
- 1 Pc. 10" Quick Release Ratchet (Pear Head).
- 2 Pcs. 5" & 10" Extension.
- 1 Pc. 1/2"F x 1/2"M 3-Function Adapter.
- 1 Pc. 2-7/8" Universal Joint.

▲ Blow Mold Box

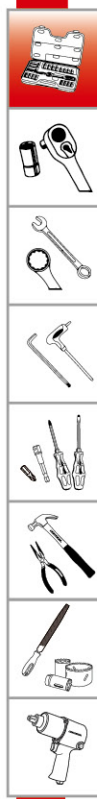

1/2" Socket Sets

1/2" Drive Metric & SAE Socket Set - 40 Pcs.



Item No.		 kgs
99-035 (12-Point)	1/4	4.5/23.0

- 18 Pcs. Sockets (Metric, 12-Point):
10, 11, 12, 13, 14, 15, 16, 17, 18, 19, 21, 22, 23, 24, 26, 27, 30, 32 mm.
- 15 Pcs. Sockets (SAE, 12-Point):
3/8", 7/16", 1/2", 9/16", 5/8", 11/16", 3/4", 13/16", 7/8", 15/16", 1", 1-1/16", 1-1/8", 1-3/16", 1-1/4".
- 1 Pc. 21mm (13/16") Spark Plug Socket.
- 1 Pc. 10" Quick Release Ratchet (Pear Head).
- 3 Pcs. 3", 5" & 10" Extension.
- 1 Pc. 10" Flex Handle.
- 1 Pc. 2-7/8" Universal Joint.

▲ Metal Box

1/2" Drive Metric Socket Set - 85 Pcs.



Item No.		 kgs
87-067	1/2	11/23

- 22 Pcs. Sockets (Metric, 6-Point):
8, 9, 10, 11, 12, 13, 14, 15, 16, 17, 18, 19, 20, 21, 22, 23, 24, 25, 27, 29, 30, 32 mm.
- 3 Pcs. Slotted Bit Sockets: 8, 10, 12 mm.
- 3 Pcs. Phillips Bit Sockets: PH2, PH3, PH4.
- 3 Pcs. POZIDRIV[®] Bit Sockets: PZ2, PZ3, PZ4.
- 9 Pcs. Hex Bit Sockets: 5, 6, 7, 8, 10, 12, 14, 17, 19 mm.
- 9 Pcs. TORX[®] Tamper Proof Bit Sockets:
T20, T25, T27, T30, T40, T45, T50, T55, T60.
- 2 Pcs. 16mm (5/8") & 21mm (13/16") Spark Plug Socket.
- 1 Pc. 10" (45 Teeth) Quick Release Ratchet (Pear Head).
- 2 Pcs. 5" & 10" Quick Release Extension.
- 1 Pc. 17" Flex Handle.
- 1 Pc. 12" Quick Release Sliding "T" Bar.
- 1 Pc. 2-7/8" Universal Joint.
- 1 Pc. 3" Extension (with LED Light).
- 9 Pcs. Deep Hex Bit Sockets: 5, 6, 7, 8, 10, 12, 14, 17, 19 mm.
- 9 Pcs. TORX[®] Deep Tamper Proof Bit Sockets:
T20, T25, T27, T30, T40, T45, T50, T55, T60.
- 9 Pcs. E-Sockets: E10, E11, E12, E14, E16, E18, E20, E22, E24.

▲ Blow Mold Box



1/2" Socket Sets

1/4" & 1/2" Drive Metric Socket Set - 87 Pcs.

Item No.		 kgs
87-049	1/2	9/18



- 14 Pcs. 1/4" Dr. - Sockets (Metric, 6-Point):
3.5, 4, 4.5, 5, 5.5, 6, 7, 8, 9, 10, 11, 12, 13, 14 mm.
- 8 Pcs. 1/4" Dr. - Deep Sockets (Metric, 6-Point):
6, 7, 8, 9, 10, 11, 12, 13 mm.
- 15 Pcs. 1/2" Dr. - Sockets (Metric, 6-Point):
10, 11, 12, 13, 14, 15, 17, 18, 19, 21, 22, 24, 27, 30, 32 mm.
- 4 Pcs. 1/4" Dr. - Deep Sockets (Metric, 6-Point):
14, 17, 19, 22 mm.
- 3 Pcs. 1/4" Dr. - Slotted Bit Sockets: 4, 5.5, 6.5 mm.
- 2 Pcs. 1/4" Dr. - Phillips Bit Sockets: PH1, PH2.
- 2 Pcs. 1/4" Dr. - POZIDRIV® Bit Sockets: PZ1, PZ2.
- 6 Pcs. 1/4" Dr. - TORX® Tamper Proof Bit Sockets:
T8, T10, T15, T20, T25, T30.
- 4 Pcs. 3/8" Dr. - Hex Bit Sockets: 3, 4, 5, 6 mm.
- 15 Pcs. Insert Bit (3/8" Hex x 25mm L):
 - ⊖ Slotted: 8, 10, 12 mm.
 - ⊕ Phillips: PH3, PH4.
 - ⊕ POZIDRIV® : PZ3, PZ4.
 - ⊕ TORX® Tamper Proof: T40, T45, T50, T55.
 - Hex: 8, 10, 12, 14 mm.
- 1 Pc. 1/2" Dr. - 10" (45 Teeth) Quick Release Ratchet (Pear Head).
- 1 Pc. 1/4" Dr. - 6" (45 Teeth) Quick Release Ratchet (Pear Head).
- 2 Pcs. 1/4" Dr. - 2" & 4" Extension.
- 2 Pcs. 1/2" Dr. - 5" & 10" Extension.
- 1 Pc. 1/2" Dr. - 3/8" (10mm) Hex Quick Release Bit Holder.
- 1 Pc. 1/4" Dr. - 1-5/16" Universal Joint.
- 1 Pc. 1/2" Dr. - 2-7/8" Universal Joint.
- 1 Pc. 1/4" Dr. - 6" Spinner.
- 2 Pcs. 1/2" Dr. - 16mm (5/8") & 21mm (13/16") Spark Plug Socket.
- 1 Pc. 1/4" Dr. - 4-1/2" Sliding "T" Bar.
- 1 Pc. Blow Mold Box.

▲ Blow Mold Box



3/8" Socket Sets

90 Pcs. Tool Set

Item No.		 kgs
99-060	1/4	5.3/22.2



- 10 Pcs. 3/8" Dr. - Sockets (Metric, 6-Point):
8, 9, 10, 11, 12, 13, 14, 15, 17, 19 mm.
- 7 Pcs. 3/8" Dr. - Sockets (SAE, 6-Point):
3/8", 7/16", 1/2", 9/16", 5/8", 11/16", 3/4".
- 10 Pcs. 1/4" Dr. - Sockets (Metric, 6-Point):
4, 4.5, 5, 6, 7, 8, 9, 10, 11, 12 mm.
- 9 Pcs. 1/4" Dr. - Sockets (SAE, 6-Point):
3/16", 7/32", 1/4", 9/32", 5/16", 11/32", 3/8", 7/16", 1/2".
- 36 Pcs. Insert Bits: (1/4" Hex x 25mm L)
 - ⊕ Phillips: PH0, PH1, (PH2 * 2), PH3.
 - Hex: 1.5, 2, 2.5, 3, 4, 5, 6 mm.
 - ⊕ POZIDRIV®: PZ0, PZ1, (PZ2 * 2), PZ3.
 - ⊕ TORX® Tamper Proof: T10, T15, T20, T25, T27, T30, T40.
 - ⊖ Slotted: 3, 4, 5, 6, 7mm.
 - Spline: M4, M5, M6.
 - Square Recess: S0, S1, S2, S3.
- 1 Pc. ○ Ball-Lock Socket Adapter: 1/4" Hex x 25mm L.
- 1 Pc. 5M x 19mm Measuring Tape.
- 1 Pc. 1/4" Dr. - 1/4" Hex Bit Adapter.
- 1 Pc. 3/8" Dr. - 1/4" Hex Bit Adapter.
- 1 Pc. 3/8" Dr. - 3/8"F x 1/4"M Socket Drive Adapter.
- 1 Pc. 3/8" Dr. - 6" Extension.
- 1 Pc. 3/8" Dr. - 8" Ratchet (Round Head).
- 1 Pc. Ratchet Screwdriver Handle (2" depth of bit holding chamber).
- 1 Pc. 1/4" Dr. - 6" L Handle.
- 1 Pc. 3/8" Dr. - 16mm (5/8") Spark Plug Socket.
- 2 Pcs. Screwdrivers - 3800 Type
 - ⊖ Slotted: 6mm x 100mm L.
 - ⊕ Phillips: 6mm x 100mm L.
- 1 Pc. 6-1/2" Long Nose Pliers.
- 1 Pc. 9" Lineman's Pliers.
- 1 Pc. Zinc Alloy with Rubber grip Utility Knife; 3 Extra Blades.
- 1 Pc. 8" Adjustable Wrench - European Type.
- 1 Pc. 12 oz. Claw Hammer with Fiberglass Handle.
- 1 Pc. 8" Mill File (Smooth Cut).

▲ Blow Mold Box



3/4" Socket Sets

3/4" Drive Metric Socket Set - 14 Pcs.



Item No.		kgs
99-012 (6-Point)	1/1	10.6/11.3
99-014 (12-Point)	1/1	10.6/11.3

- 10 Pcs. Sockets (Metric):
22, 24, 27, 30, 32, 36, 38, 41, 46, 50 mm.
- 1 Pc. 18" Sliding "T" Bar.
- 1 Pc. 20" Quick Release Ratchet (Round Head).
- 2 Pcs. 4" & 8" Extension.

▲ Blow Mold Box

3/4" Drive Metric Socket Set - 14 Pcs.



Item No.		kgs
99-072 (6-Point)	1/1	10.6/11.3
99-074 (12-Point)	1/1	10.6/11.3

- 10 Pcs. Sockets (Metric):
22, 24, 27, 30, 32, 36, 38, 41, 46, 50 mm.
- 1 Pc. 18" Quick Release Sliding "T" Bar.
- 1 Pc. 20" Quick Release Ratchet (Round Head).
- 2 Pcs. 4" & 8" Quick Release Extension.

▲ Blow Mold Box

3/4" Drive SAE Socket Set - 14 Pcs.



Item No.		kgs
99-073 (6-Point)	1/1	10.6/11.3
99-075 (12-Point)	1/1	10.6/11.3

- 10 Pcs. Sockets (SAE):
7/8", 15/16", 1", 1-1/8", 1-1/4", 1-7/16", 1-1/2", 1-5/8", 1-3/4", 2".
- 1 Pc. 18" Quick Release Sliding "T" Bar.
- 1 Pc. 20" Quick Release Ratchet (Round Head).
- 2 Pcs. 4" & 8" Quick Release Extension.

▲ Blow Mold Box

3/4" Socket Sets



3/4" Drive Metric Socket Set - 21 Pcs.

Item No.		kgs
99-076 (6-Point)	1/1	15.5/16.2
99-078 (12-Point)	1/1	15.5/16.2

- 16 Pcs. Sockets (Metric):
19, 21, 22, 23, 24, 26, 27, 29, 30, 32, 35, 36, 38, 41, 46, 50 mm.
 - 1 Pc. 20" Quick Release Ratchet (Round Head).
 - 1 Pc. 20" Quick Release Flex Handle.
 - 2 Pcs. 8" & 16" Quick Release Extension.
 - 1 Pc. 4" Universal Joint.
- ▲ Blow Mold Box



3/4" Drive SAE Socket Set - 21 Pcs.

Item No.		kgs
99-077 (6-Point)	1/1	15.5/16.2
99-079 (12-Point)	1/1	15.5/16.2

- 16 Pcs. Sockets (SAE):
7/8", 15/16", 1", 1-1/16", 1-1/8", 1-3/16", 1-1/4", 1-5/16",
1-3/8", 1-7/16", 1-1/2", 1-5/8", 1-3/4", 1-13/16", 1-7/8", 2".
 - 1 Pc. 20" Quick Release Ratchet (Round Head).
 - 1 Pc. 20" Quick Release Flex Handle.
 - 2 Pcs. 8" & 16" Quick Release Extension.
 - 1 Pc. 4" Universal Joint.
- ▲ Blow Mold Box



3/4" Drive Metric Socket Set - 22 Pcs.

Item No.		kgs
87-068	1/1	18/18.5

- 17 Pcs. Sockets (Metric, 12-Point):
21, 22, 24, 27, 29, 30, 32, 34, 35, 36, 38, 41, 46, 50, 55, 60, 65 mm.
 - 2 Pcs. 4" & 8" Extension.
 - 1 Pc. 20" (43Teenth) Quick Release Ratchet (Extendable); 500~830mm.
 - 1 Pc. 18" Sliding "T" Bar.
 - 1 Pc. 4" Universal Joint.
- ▲ Metal Box

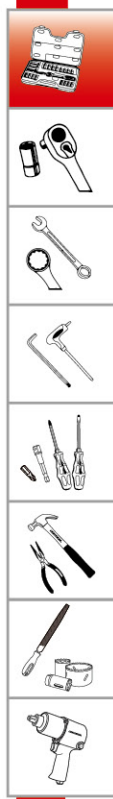

3/4" Socket Sets

3/4" Drive Metric Socket Set - 21 Pcs.



Item No.		 kgs
99-086 (6-Point)	1/1	15.3/15.7
87-004 (12-Point)	1/1	15.3/15.7

- 16 Pcs. Sockets (Metric):
17, 19, 21, 22, 23, 24, 27, 29, 30, 32, 35, 36, 38, 41, 46, 50 mm.
- 3 Pcs. 4" & 8" & 16" Extension.
- 1 Pc. 20" Quick Release Ratchet (Round Head).
- 1 Pc. 20" Sliding "T" Bar.

▲ Metal Box

3/4" Drive SAE Socket Set - 21 Pcs.



Item No.		 kgs
87-003 (6-Point)	1/1	15.3/15.7
99-087 (12-Point)	1/1	15.3/15.7

- 16 Pcs. Sockets (SAE):
3/4", 7/8", 15/16", 1", 1-1/16", 1-1/8", 1-3/16", 1-1/4", 1-5/16",
1-3/8", 1-7/16", 1-1/2", 1-9/16", 1-5/8", 1-3/4", 2".
- 3 Pcs. 4" & 8" & 16" Extension.
- 1 Pc. 20" Quick Release Ratchet (Round Head).
- 1 Pc. 20" Sliding "T" Bar.

▲ Metal Box

3/4" Drive Metric & SAE Socket Set - 26 Pcs.



Item No.		 kgs
99-033 (12-Point)	1/1	22.3/22.7

- 10 Pcs. Sockets (Metric, 12-Point):
22, 24, 27, 30, 32, 36, 38, 41, 46, 50 mm.
- 12 Pcs. Sockets (SAE, 12-Point):
7/8", 15/16", 1", 1-1/8", 1-1/4", 1-5/16", 1-3/8", 1-7/16",
1-5/8", 1-3/4", 1-7/8", 2".
- 2 Pcs. 4" & 8" Extension.
- 1 Pc. 20" Quick Release Ratchet (Pear Head).
- 1 Pc. 18" Flex Handle.

▲ Metal Box

1/4" Drive



Ratchet (Round Head)

Item No.	Size (L)		kgs
96-119	6" 43 Teeth	6/120	1.0/20.2



Quick Release Ratchet (Round Head)

Item No.	Size (L)		kgs
96-713	6" 43 Teeth	6/120	1.0/21.0



Quick Release Ratchet (Pear Head)

Item No.	Size (L)		kgs
97-927	6" 24 Teeth	6/120	1.0/21.0
97-925	6" 45 Teeth	6/120	1.0/21.0



Quick Release Ratchet (Compact Pear Head w/Steel Handle)

Item No.	Size (L)		kgs
97-924	6" 72 Teeth	6/120	1.0/20.5



Spinner

Item No.	Size (L)		kgs
96-004	6"	6/120	0.8/14.0



Flex Handle

Item No.	Size (L)		kgs
96-012	6"	6/72	0.8/10.2



2-Way "L" Handle

Item No.	Size (L)		kgs
96-492	6"	20/200	1.6/16.0

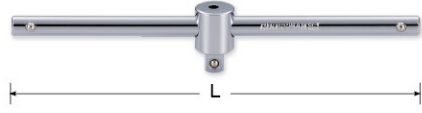

Sliding "T" Bar

Item No.	Size (L)		kgs
96-010	4-1/2"	20/240	1.0/13.0



1/4" Drive

1/4" Drive Standard - 6 Point Sockets (Metric)

Item No.	Size (A)	Length		 kgs
96-113	3.5 mm	25 mm	10/300	0.1/4.2
96-101	4 mm	25 mm	10/300	0.1/4.2
96-110	4.5 mm	25 mm	10/300	0.1/4.2
96-102	5 mm	25 mm	10/300	0.1/4.2
96-111	5.5 mm	25 mm	10/300	0.1/4.3
96-103	6 mm	25 mm	10/300	0.1/4.4
96-104	7 mm	25 mm	10/300	0.1/4.6
96-105	8 mm	25 mm	10/300	0.1/4.7
96-106	9 mm	25 mm	10/300	0.2/5.6
96-107	10 mm	25 mm	10/300	0.2/5.9
96-108	11 mm	25 mm	10/300	0.2/7.7
96-109	12 mm	25 mm	10/300	0.3/8.8
96-112	13 mm	25 mm	10/300	0.3/9.5
96-114	14 mm	25 mm	10/300	0.4/12.0

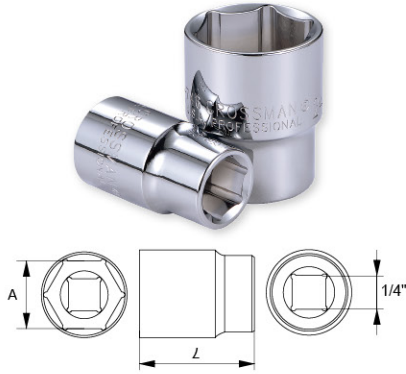

1/4" Drive Standard - 6 Point Sockets (SAE)

Item No.	Size (A)	Length		 kgs
96-021	5/32"	25 mm	10/300	0.1/4.1
96-022	3/16"	25 mm	10/300	0.1/4.3
96-023	7/32"	25 mm	10/300	0.1/4.3
96-024	1/4"	25 mm	10/300	0.1/4.3
96-025	9/32"	25 mm	10/300	0.1/4.6
96-026	5/16"	25 mm	10/300	0.1/4.7
96-027	11/32"	25 mm	10/300	0.2/5.5
96-028	3/8"	25 mm	10/300	0.2/6.1
96-029	7/16"	25 mm	10/300	0.2/7.6
96-030	1/2"	25 mm	10/300	0.3/9.5
96-020	9/16"	25 mm	10/300	0.4/12.0



1/4" Drive Standard - 12 Point Sockets (Metric)

Item No.	Size (A)	Length		 kgs
96-050	3.5 mm	25 mm	10/300	0.1/4.2
96-051	4 mm	25 mm	10/300	0.1/4.2
96-052	4.5 mm	25 mm	10/300	0.1/4.2
96-053	5 mm	25 mm	10/300	0.1/4.2
96-054	5.5 mm	25 mm	10/300	0.1/4.3
96-055	6 mm	25 mm	10/300	0.1/4.4
96-056	7 mm	25 mm	10/300	0.1/4.6
96-057	8 mm	25 mm	10/300	0.1/4.7
96-058	9 mm	25 mm	10/300	0.2/5.6
96-059	10 mm	25 mm	10/300	0.2/5.9
96-060	11 mm	25 mm	10/300	0.2/7.7
96-061	12 mm	25 mm	10/300	0.3/8.8
96-062	13 mm	25 mm	10/300	0.3/9.5
96-063	14 mm	25 mm	10/300	0.4/12.0



1/4" Drive

1/4" Drive Standard - 12 Point Sockets (SAE)

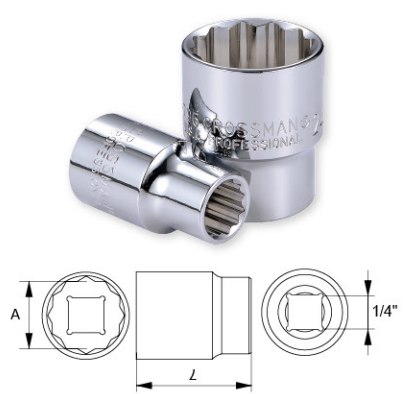

Item No.	Size (A)	Length		kgs
96-049	5/32"	25 mm	10/300	0.1/4.1
96-045	3/16"	25 mm	10/300	0.1/4.3
96-046	7/32"	25 mm	10/300	0.1/4.3
96-039	1/4"	25 mm	10/300	0.1/4.3
96-047	9/32"	25 mm	10/300	0.1/4.6
96-040	5/16"	25 mm	10/300	0.1/4.7
96-048	11/32"	25 mm	10/300	0.2/5.5
96-041	3/8"	25 mm	10/300	0.2/6.1
96-042	7/16"	25 mm	10/300	0.2/7.6
96-043	1/2"	25 mm	10/300	0.3/9.5
96-044	9/16"	25 mm	10/300	0.4/12.0

1/4" Drive Deep - 6 Point Sockets (Metric)



Item No.	Size (A)	Length		kgs
98-935	4 mm	50 mm	12/312	0.2/6.5
96-179	4.5 mm	50 mm	12/312	0.3/6.9
96-093	5 mm	50 mm	12/312	0.3/7.0
96-361	5.5 mm	50 mm	12/312	0.3/7.2
96-094	6 mm	50 mm	12/312	0.3/7.5
96-195	7 mm	50 mm	12/312	0.3/8.0
96-096	8 mm	50 mm	12/312	0.3/8.2
96-097	9 mm	50 mm	12/312	0.4/10.2
96-098	10 mm	50 mm	12/312	0.4/11.8
96-099	11 mm	50 mm	12/312	0.5/14.4
96-100	12 mm	50 mm	12/312	0.6/16.0
96-116	13 mm	50 mm	12/312	0.7/17.4
96-289	14 mm	50 mm	12/312	0.9/23.2

1/4" Drive Deep - 6 Point Sockets (SAE)



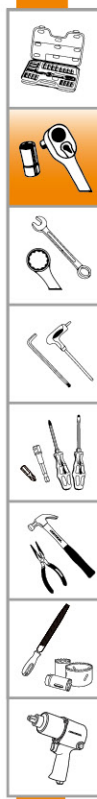

Item No.	Size (A)	Length		kgs
96-031	5/32"	50 mm	12/312	0.2/6.6
96-032	3/16"	50 mm	12/312	0.3/7.0
96-033	7/32"	50 mm	12/312	0.3/7.3
96-034	1/4"	50 mm	12/312	0.3/7.6
96-035	9/32"	50 mm	12/312	0.3/7.8
96-036	5/16"	50 mm	12/312	0.3/7.7
96-037	11/32"	50 mm	12/312	0.4/11.8
96-038	3/8"	50 mm	12/312	0.4/11.1



1/4" Drive

1/4" Drive Deep -12 Point Sockets (Metric)

Item No.	Size (A)	Length		 kgs
98-330	4 mm	50 mm	12/312	0.2/6.5
98-331	4.5 mm	50 mm	12/312	0.3/6.9
98-332	5 mm	50 mm	12/312	0.3/7.0
98-333	5.5 mm	50 mm	12/312	0.3/7.2
98-334	6 mm	50 mm	12/312	0.3/7.5
98-335	7 mm	50 mm	12/312	0.3/8.0
98-336	8 mm	50 mm	12/312	0.3/8.2
98-337	9 mm	50 mm	12/312	0.4/10.2
98-338	10 mm	50 mm	12/312	0.4/11.8
98-339	11 mm	50 mm	12/312	0.5/14.4
98-340	12 mm	50 mm	12/312	0.6/16.0
98-341	13 mm	50 mm	12/312	0.7/17.4
98-342	14 mm	50 mm	12/312	0.9/23.2



1/4" Drive Deep -12 Point Sockets (SAE)

Item No.	Size (A)	Length		 kgs
96-181	5/32"	50 mm	12/312	0.2/6.6
96-182	3/16"	50 mm	12/312	0.3/7.0
96-183	7/32"	50 mm	12/312	0.3/7.3
96-184	1/4"	50 mm	12/312	0.3/7.6
96-185	9/32"	50 mm	12/312	0.3/7.8
96-186	5/16"	50 mm	12/312	0.3/7.7
96-187	11/32"	50 mm	12/312	0.4/11.8
96-188	3/8"	50 mm	12/312	0.4/11.1



1/4" Drive E-Sockets (For TORX® Head Screws)

Item No.	Size (A)	Length		 kgs
93-701	E4	25 mm	10/300	0.1/4.4
93-702	E5	25 mm	10/300	0.1/4.4
93-703	E6	25 mm	10/300	0.1/4.4
93-704	E7	25 mm	10/300	0.1/4.7
93-705	E8	25 mm	10/300	0.2/4.8
93-707	E10	25 mm	10/300	0.2/6.0



1/4" Drive Phillips Bit Sockets

Item No.	Size	Length		 kgs
99-401	PH1	37 mm	12/480	0.2/8.1
99-402	PH2	37 mm	12/480	0.2/8.1
99-403	PH3	37 mm	12/480	0.2/8.1



1/4" Drive



1/4" Drive Slotted Bit Sockets

Item No.	Size	Length		kgs
99-411	4.0 mm	37 mm	12/480	0.2/8.1
99-414	5.5 mm	37 mm	12/480	0.2/8.3
99-416	6.5 mm	37 mm	12/480	0.2/8.6
99-417	7.0 mm	37 mm	12/480	0.2/8.8
99-418	8.0 mm	37 mm	12/480	0.2/8.9



1/4" Drive Hex Bit Sockets (Metric)

Item No.	Size	Length		kgs
99-423	3.0 mm	37 mm	12/480	0.2/7.8
99-424	4.0 mm	37 mm	12/480	0.2/8.1
99-425	5.0 mm	37 mm	12/480	0.2/8.4
99-426	6.0 mm	37 mm	12/480	0.2/8.6
99-427	7.0 mm	37 mm	12/480	0.2/9.2
99-428	8.0 mm	37 mm	12/480	0.2/9.9



1/4" Drive TORX[®] Bit Sockets

Item No.	Size	Length		kgs
99-455	T10	37 mm	12/480	0.2/7.8
99-456	T15	37 mm	12/480	0.2/7.8
99-457	T20	37 mm	12/480	0.2/7.9
99-458	T25	37 mm	12/480	0.2/8.0
99-459	T27	37 mm	12/480	0.2/8.1
99-460	T30	37 mm	12/480	0.2/8.2
99-462	T40	37 mm	12/480	0.2/8.4



1/4" Drive TORX[®] Tamper Proof Bit Sockets

Item No.	Size	Length		kgs
99-475	T10	37 mm	12/480	0.2/7.8
99-476	T15	37 mm	12/480	0.2/8.1
99-477	T20	37 mm	12/480	0.2/7.9
99-478	T25	37 mm	12/480	0.2/8.0
99-479	T27	37 mm	12/480	0.2/8.0
99-480	T30	37 mm	12/480	0.2/8.1
99-482	T40	37 mm	12/480	0.2/8.4



1/4" Drive POZIDRIV[®] Bit Sockets

Item No.	Size	Length		kgs
99-406	PZ1	37 mm	12/480	0.2/8.1
99-407	PZ2	37 mm	12/480	0.2/8.1
99-408	PZ3	37 mm	12/480	0.2/8.1



3/8" Drive



Ratchet (Round Head)

Item No.	Size (L)		kgs
96-203	8" 41 Teeth	6/60	2.2/22.8



Quick Release Ratchet (Round Head)

Item No.	Size (L)		kgs
96-714	8" 41 Teeth	6/60	2.2/23.0



Quick Release Ratchet (Pear Head)

Item No.	Size (L)		kgs
97-931	8" 24 Teeth	6/60	2.1/22.0
97-932	8" 45 Teeth	6/60	2.1/22.0



Quick Release Ratchet (Compact Pear Head w/Steel Handle)

Item No.	Size (L)		kgs
97-934	8" 72 Teeth	6/60	2.0/20.0



Flex Handle

Item No.	Size (L)		kgs
96-213	8"	6/60	1.9/15.2



2-Way "L" Handle

Item No.	Size (L)		kgs
96-218	8"	10/100	2.0/21.1



Sliding "T" Bar

Item No.	Size (L)		kgs
96-202	8"	6/60	1.2/12.0

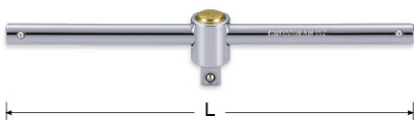

Quick Release Sliding "T" Bar

Item No.	Size (L)		kgs
97-308	8"	6/60	1.1/11.0

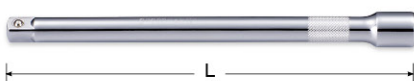

Extensions

Item No.	Size (L)		kgs
96-206	3"	20/240	1.6/19.2
96-207	6"	15/150	2.2/22.8
96-209	8"	20/120	3.9/24.2
96-208	10"	20/80	4.8/19.8



3/8" Drive

3/8" Drive Standard - 6 Point Sockets (Metric)

Item No.	Size (A)	Length		 kgs
96-301	6 mm	28 mm	10/300	0.3/8.9
96-302	7 mm	28 mm	10/300	0.3/8.9
96-303	8 mm	28 mm	10/300	0.3/8.9
96-304	9 mm	28 mm	10/300	0.3/8.9
96-305	10 mm	28 mm	10/300	0.3/9.0
96-306	11 mm	28 mm	10/300	0.3/9.3
96-307	12 mm	28 mm	10/300	0.3/9.3
96-308	13 mm	28 mm	10/300	0.3/9.7
96-309	14 mm	28 mm	10/200	0.4/8.0
96-310	15 mm	28 mm	10/200	0.5/10.5
96-311	16 mm	28 mm	10/200	0.5/10.5
96-312	17 mm	30 mm	10/200	0.7/13.5
96-313	18 mm	30 mm	10/200	0.7/15.2
96-314	19 mm	30 mm	10/200	0.8/15.7
98-133	20 mm	30 mm	10/200	0.9/18.6
96-316	21 mm	30 mm	10/200	0.9/18.6
96-317	22 mm	30 mm	10/200	1.0/20.4
98-136	23 mm	30 mm	10/200	1.2/23.8
98-137	24 mm	30 mm	10/200	1.2/23.8



3/8" Drive Standard - 6 Point Sockets (SAE)

Item No.	Size (A)	Length		 kgs
96-255	1/4"	28 mm	10/300	0.3/8.6
96-256	5/16"	28 mm	10/300	0.3/8.6
98-973	11/32"	28 mm	10/300	0.3/8.9
98-976	3/8"	28 mm	10/300	0.3/8.9
98-977	7/16"	28 mm	10/300	0.3/9.2
98-974	15/32"	28 mm	10/300	0.3/9.2
98-978	1/2"	28 mm	10/300	0.3/9.9
98-979	9/16"	28 mm	10/200	0.4/7.8
98-975	19/32"	28 mm	10/200	0.5/9.6
98-980	5/8"	28 mm	10/200	0.5/9.6
98-161	11/16"	30 mm	10/200	0.6/13.0
98-162	3/4"	30 mm	10/200	0.7/14.5
98-163	25/32"	30 mm	10/200	0.9/18.2
98-164	13/16"	30 mm	10/200	0.9/18.2
98-165	7/8"	30 mm	10/200	1.1/21.6
98-166	15/16"	30 mm	10/200	1.1/23.2



3/8" Drive

3/8" Drive Standard - 12 Point Sockets (Metric)

Item No.	Size (A)	Length		 kgs
96-342	7 mm	28 mm	10/300	0.3/8.9
96-343	8 mm	28 mm	10/300	0.3/8.9
96-344	9 mm	28 mm	10/300	0.3/8.9
96-345	10 mm	28 mm	10/300	0.3/9.0
96-346	11 mm	28 mm	10/300	0.3/9.3
96-347	12 mm	28 mm	10/300	0.3/9.3
96-348	13 mm	28 mm	10/300	0.3/9.7
96-349	14 mm	28 mm	10/200	0.4/8.0
96-350	15 mm	28 mm	10/200	0.5/10.5
96-351	16 mm	28 mm	10/200	0.5/10.5
96-352	17 mm	30 mm	10/200	0.7/13.5
98-146	18 mm	30 mm	10/200	0.7/15.2
98-147	19 mm	30 mm	10/200	0.8/15.7
98-148	20 mm	30 mm	10/200	0.9/18.6
98-149	21 mm	30 mm	10/200	0.9/18.6
98-150	22 mm	30 mm	10/200	1.0/20.4
98-152	24 mm	30 mm	10/200	1.2/23.8



3/8" Drive Standard - 12 Point Sockets (SAE)

Item No.	Size (A)	Length		 kgs
96-260	1/4"	28 mm	10/300	0.3/8.6
96-261	5/16"	28 mm	10/300	0.3/8.6
98-173	11/32"	28 mm	10/300	0.3/8.9
96-262	3/8"	28 mm	10/300	0.3/8.9
96-263	7/16"	28 mm	10/300	0.3/9.2
96-264	1/2"	28 mm	10/300	0.3/9.9
96-265	9/16"	28 mm	10/200	0.4/7.8
96-266	5/8"	28 mm	10/200	0.5/9.6
98-176	11/16"	30 mm	10/200	0.6/13.0
98-177	3/4"	30 mm	10/200	0.7/14.5
98-179	13/16"	30 mm	10/200	0.9/18.2
98-180	7/8"	30 mm	10/200	1.1/21.6

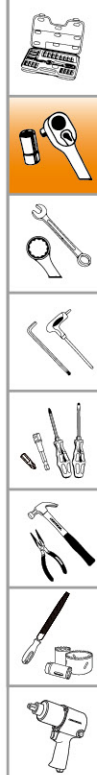

3/8" Drive

3/8" Drive Deep - 6 Point Sockets (Metric)

Item No.	Size (A)	Length		 kgs
96-320	8 mm	63 mm	12/360	0.7/19.8
96-321	9 mm	63 mm	12/360	0.7/21.7
96-322	10 mm	63 mm	12/360	0.7/22.1
96-323	11 mm	63 mm	12/360	0.8/23.2
96-324	12 mm	63 mm	12/240	0.8/17.3
96-325	13 mm	63 mm	12/240	0.8/17.3
96-326	14 mm	63 mm	12/240	1.0/20
96-327	15 mm	63 mm	12/240	1.3/25
98-825	16 mm	63 mm	12/240	1.3/25
96-328	17 mm	63 mm	12/120	1.5/15
98-326	18 mm	63 mm	12/120	1.9/19
96-329	19 mm	63 mm	12/120	1.9/19
98-328	21 mm	63 mm	12/120	2.0/21



3/8" Drive Deep - 6 Point Sockets (SAE)

Item No.	Size (A)	Length		 kgs
98-983	1/4"	63 mm	12/360	0.7/19.8
98-984	5/16"	63 mm	12/360	0.7/21.7
98-985	3/8"	63 mm	12/360	0.7/22.1
98-986	7/16"	63 mm	12/360	0.8/23.2
98-987	1/2"	63 mm	12/240	0.8/16.0
98-988	9/16"	63 mm	12/240	1.0/20.6
98-989	5/8"	63 mm	12/240	1.2/23
98-990	11/16"	63 mm	12/120	1.5/15
98-991	3/4"	63 mm	12/120	1.7/17.3
98-992	13/16"	63 mm	12/120	2.1/21.3



3/8" Drive Deep - 12 Point Sockets (Metric)

Item No.	Size (A)	Length		 kgs
96-520	8 mm	63 mm	12/360	0.7/19.8
96-521	9 mm	63 mm	12/360	0.7/21.7
96-522	10 mm	63 mm	12/360	0.7/22.1
96-523	11 mm	63 mm	12/360	0.8/23.2
96-524	12 mm	63 mm	12/240	0.8/17.3
96-525	13 mm	63 mm	12/240	0.8/17.3
96-526	14 mm	63 mm	12/240	1.0/20
96-527	15 mm	63 mm	12/240	1.3/25
98-528	16 mm	63 mm	12/240	1.3/25
96-529	17 mm	63 mm	12/120	1.5/15
98-530	18 mm	63 mm	12/120	1.9/19
96-531	19 mm	63 mm	12/120	1.9/19
98-532	21 mm	63 mm	12/120	2.0/21



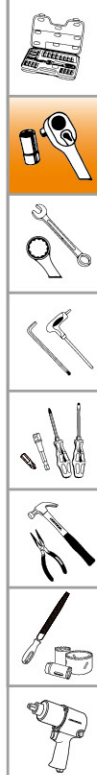



3/8" Drive

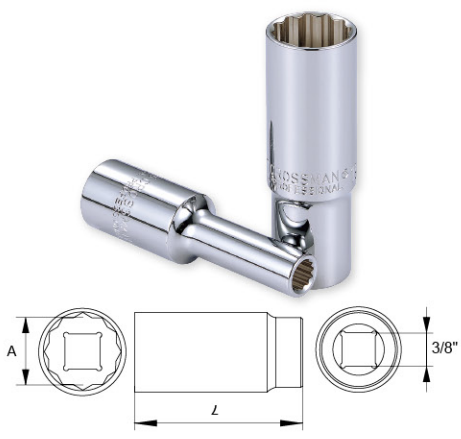

3/8" Drive Deep - 12 Point Sockets (SAE)



Item No.	Size (A)	Length	 	 kgs
98-350	1/4"	63 mm	12/360	0.7/19.8
98-351	5/16"	63 mm	12/360	0.7/21.7
98-352	3/8"	63 mm	12/360	0.7/22.1
98-353	7/16"	63 mm	12/360	0.8/23.2
98-354	1/2"	63 mm	12/240	0.8/16.0
98-355	9/16"	63 mm	12/240	1.0/20.6
98-356	5/8"	63 mm	12/240	1.2/23
98-357	11/16"	63 mm	12/120	1.5/15
98-358	3/4"	63 mm	12/120	1.7/17.3
98-359	13/16"	63 mm	12/120	2.1/21.3



3/8" Drive Spark Plug Sockets



Item No.	Size (A)	Length	 	 kgs
96-380	16 mm (5/8")	65 mm	10/120	1.0/13.0
96-385	18 mm (23/32")	67 mm	10/100	1.3/13.2
96-381	21 mm (13/16")	67 mm	10/100	1.5/15.6



3/8" Drive Spark Plug Sockets - Magnetic 



Item No.	Size (A)	Length	 	 kgs
96-382	16 mm (5/8")	65 mm	10/120	1.0/13.0
96-384	18 mm (23/32")	67 mm	10/100	1.3/13.7
98-383	21 mm (13/16")	67 mm	10/100	1.6/16.4



3/8" Drive E-Sockets (For TORX[®] Head Screws)



Item No.	Size (A)	Length	 	 kgs
99-731	E6	27.5 mm	10/300	0.2/7.0
99-732	E7	27.5 mm	10/300	0.2/5.2
99-733	E8	27.5 mm	10/300	0.3/8.3
99-735	E10	27.5 mm	10/300	0.3/8.8
99-736	E11	27.5 mm	10/300	0.3/8.9
99-737	E12	27.5 mm	10/300	0.3/9.0
99-739	E14	27.5 mm	10/300	0.3/10
99-741	E16	27.5 mm	10/200	0.4/8.8
99-743	E18	28.5 mm	10/200	0.6/11.5
99-745	E20	28.5 mm	10/200	1.1/21.6

3/8" Drive

■ **3/8" Drive Phillips Bit Sockets**

Item No.	Size	Length	 	 kgs
96-335	PH1	48 mm	12/360	0.48/16.8
96-177	PH2	48 mm	12/360	0.48/16.8
96-336	PH3	48 mm	12/360	0.48/16.8
96-337	PH4	48 mm	12/360	0.48/16.8



■ **3/8" Drive Slotted Bit Sockets**

Item No.	Size	Length	 	 kgs
99-151	4.0 mm	48 mm	12/360	0.48/16.8
99-158	5.0 mm	48 mm	12/360	0.48/16.8
99-153	5.5 mm	48 mm	12/360	0.48/16.8
99-159	6.0 mm	48 mm	12/360	0.48/16.8
99-154	6.5 mm	48 mm	12/360	0.48/16.8
99-155	7.0 mm	48 mm	12/360	0.48/16.8
99-156	8.0 mm	48 mm	12/360	0.48/16.8
99-157	10.0 mm	48 mm	12/360	0.48/16.8





■ **3/8" Drive Hex Bit Sockets (Metric)**

Item No.	Size	Length	 	 kgs
97-965	3 mm	48 mm	12/360	0.48/16.8
97-971	4 mm	48 mm	12/360	0.48/16.8
97-972	5 mm	48 mm	12/360	0.48/16.8
97-973	6 mm	48 mm	12/360	0.48/16.8
97-974	7 mm	48 mm	12/360	0.48/16.8
97-975	8 mm	48 mm	12/360	0.48/16.8
97-976	10 mm	48 mm	12/360	0.48/16.8
97-977	12 mm	48 mm	12/360	0.48/16.8
97-978	14 mm	48 mm	12/360	0.48/16.8



■ **3/8" Drive Hex Bit Sockets (SAE)**

Item No.	Size	Length	 	 kgs
96-387	1/8"	48 mm	12/360	0.48/16.8
96-388	5/32"	48 mm	12/360	0.48/16.8
96-389	3/16"	48 mm	12/360	0.48/16.8
96-390	7/32"	48 mm	12/360	0.48/16.8
96-391	1/4"	48 mm	12/360	0.48/16.8
96-392	5/16"	48 mm	12/360	0.48/16.8



3/8" Drive



3/8" Drive TORX[®] Bit Sockets



Item No.	Size	Length		 kgs
97-404	T-10	48 mm	12/360	0.48/16.8
97-141	T-15	48 mm	12/360	0.48/16.8
97-142	T-20	48 mm	12/360	0.48/16.8
97-143	T-25	48 mm	12/360	0.48/16.8
97-406	T-27	48 mm	12/360	0.48/16.8
97-144	T-30	48 mm	12/360	0.48/16.8
97-145	T-40	48 mm	12/360	0.48/16.8
97-146	T-45	48 mm	12/360	0.48/16.8
97-147	T-50	48 mm	12/360	0.48/16.8



3/8" Drive TORX[®] Tamper Proof Bit Sockets



Item No.	Size	Length		 kgs
97-510	T-10	48 mm	12/360	0.48/16.8
97-515	T-15	48 mm	12/360	0.48/16.8
97-520	T-20	48 mm	12/360	0.48/16.8
97-525	T-25	48 mm	12/360	0.48/16.8
97-527	T-27	48 mm	12/360	0.48/16.8
97-530	T-30	48 mm	12/360	0.48/16.8
97-540	T-40	48 mm	12/360	0.48/16.8
97-545	T-45	48 mm	12/360	0.48/16.8
97-550	T-50	48 mm	12/360	0.48/16.8
97-555	T-55	48 mm	12/360	0.48/16.8
97-560	T-60	48 mm	12/360	0.48/16.8

3/8" Drive POZIDRIV[®] Bit Sockets



Item No.	Size	Length		 kgs
99-506	PZ1	48 mm	12/360	0.48/16.8
99-507	PZ2	48 mm	12/360	0.48/16.8
99-508	PZ3	48 mm	12/360	0.48/16.8
97-509	PZ4	48 mm	12/360	0.48/16.8

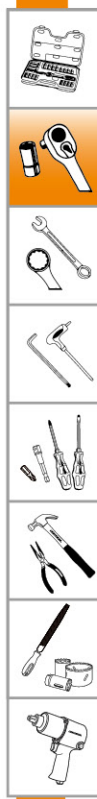

1/2" Drive



Ratchet (Round Head)

Item No.	Size (L)		kgs
96-404	10" 45 Teeth	4/40	2.5/25



Quick Release Ratchet (Round Head)

Item No.	Size (L)		kgs
96-715	10" 45 Teeth	4/40	2.6/24.8



Quick Release Ratchet (Pear Head)

Item No.	Size (L)		kgs
97-935	10" 24 Teeth	4/40	2.5/24.8
97-937	10" 45 Teeth	4/40	2.5/24.8
97-928	10" 72 Teeth	4/40	2.5/24.8



Quick Release Ratchet (Compact Pear Head w/Steel Handle)

Item No.	Size (L)		kgs
97-938	10" 72 Teeth	4/40	2.6/24.8



Flex Handles

Item No.	Size (L)		kgs
96-405	10"	6/36	3.1/18.6
96-415	15"	4/24	3.1/19.1
96-413	17"	4/16	3.6/14.4



"L" Knurled Handle

Item No.	Size (L)		kgs
96-493	8"	10/60	4.0/24.0



1/2" Drive



2-Way "L" Handles

Item No.	Size (L)		kgs
96-494	10"	10/40	4.5/19
96-495	12"	10/40	5.1/21.6

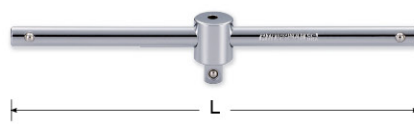

Sliding "T" Bars

Item No.	Size (L)		kgs
96-440	10"	6/60	2.2/22.2
96-448	12"	6/36	2.6/15.6

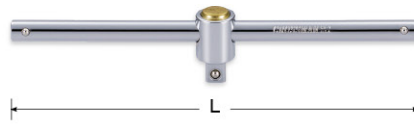

Quick Release Sliding "T" Bar

Item No.	Size (L)		kgs
96-449	10"	6/48	2.1/17.4



Extensions

Item No.	Size (L)		kgs
96-406	3"	10/120	1.3/16.1
96-407	5"	10/100	2.1/21.3
96-408	10"	10/60	4.0/24.0

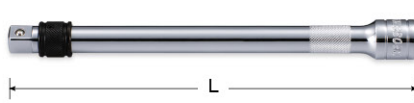

Quick Release Extensions

Item No.	Size (L)		kgs
96-516	3"	10/120	1.6/20.0
96-517	5"	10/100	2.4/25.0
96-518	10"	10/60	4.5/27.0



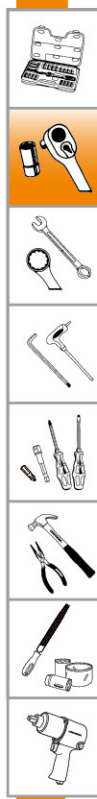

Wobble Extensions(2-Stage)

Item No.	Size (L)		kgs
97-003	3"	10/120	1.4/17.6
97-005	5"	10/100	2.2/23.0
97-010	10"	10/60	4.3/25.8



1/2" Drive

1/2" Drive Standard - 6 Point Sockets (Metric)

Item No.	Size (A)	Length		 kgs
96-508	8 mm	38 mm	10/200	0.5/10.5
96-509	9 mm	38 mm	10/200	0.5/10.8
96-510	10 mm	38 mm	10/200	0.5/10.8
96-511	11 mm	38 mm	10/200	0.5/11.2
96-512	12 mm	38 mm	10/200	0.6/11.5
96-513	13 mm	38 mm	10/200	0.5/11.5
96-514	14 mm	38 mm	10/200	0.6/11.9
96-515	15 mm	38 mm	10/200	0.6/12.3
98-738	16 mm	38 mm	10/200	0.6/11.4
98-739	17 mm	38 mm	10/200	0.7/14.5
98-740	18 mm	38 mm	10/200	0.9/18.6
98-741	19 mm	38 mm	10/200	0.8/16.5
98-742	20 mm	38 mm	10/200	1.0/20.4
98-743	21 mm	38 mm	10/200	1.0/19.3
98-744	22 mm	38 mm	10/200	0.9/19.3
98-745	23 mm	38 mm	10/200	1.1/22.6
98-746	24 mm	38 mm	10/200	1.1/21.4
98-747	25 mm	42 mm	10/100	1.4/14.5
98-748	26 mm	42 mm	10/100	1.3/13.6
98-749	27 mm	42 mm	10/100	1.5/15.5
98-750	28 mm	42 mm	10/100	1.5/15.7
98-751	29 mm	42 mm	10/100	1.6/16.9
98-752	30 mm	44 mm	10/100	2.0/20.8
98-754	31 mm	44 mm	10/100	2.0/20.2
98-753	32 mm	44 mm	10/100	2.2/22.8



1/2" Drive Standard - 6 Point Sockets (SAE)



Item No.	Size (A)	Length		 kgs
96-441	5/16"	38 mm	10/200	0.5/10.4
96-442	3/8"	38 mm	10/200	0.5/10.7
96-443	7/16"	38 mm	10/200	0.5/10.9
98-777	15/32"	38 mm	10/200	0.5/10.9
96-444	1/2"	38 mm	10/200	0.6/11.6
96-445	9/16"	38 mm	10/200	0.6/11.4
98-778	19/32"	38 mm	10/200	0.6/12.0
98-766	5/8"	38 mm	10/200	0.6/11.6
98-767	11/16"	38 mm	10/200	0.7/14.5
98-779	23/32"	38 mm	10/200	0.9/18.6
98-768	3/4"	38 mm	10/200	0.8/16.4
98-780	25/32"	38 mm	10/200	1.0/20.4
98-769	13/16"	38 mm	10/200	1.0/20.2
98-770	7/8"	38 mm	10/200	0.9/19.0
98-771	15/16"	38 mm	10/200	1.1/23.0
98-773	1"	42 mm	10/100	1.4/14.2
98-774	1-1/16"	42 mm	10/100	1.5/14.9
96-458	1-1/8"	42 mm	10/100	1.6/16.5
98-775	1-3/16"	44 mm	10/100	1.8/18.9
98-776	1-1/4"	44 mm	10/100	2.0/21.0



Hand Sockets

1/2" Drive

1/2" Drive Standard - 12 Point Sockets (Metric)

Item No.	Size (A)	Length		 kgs
96-540	8 mm	38 mm	10/200	0.5/10.4
96-541	9 mm	38 mm	10/200	0.5/10.4
96-542	10 mm	38 mm	10/200	0.5/10.5
96-543	11 mm	38 mm	10/200	0.5/10.9
96-544	12 mm	38 mm	10/200	0.5/11.2
96-545	13 mm	38 mm	10/200	0.6/11.5
96-546	14 mm	38 mm	10/200	0.6/11.9
96-547	15 mm	38 mm	10/200	0.6/11.9
98-788	16 mm	38 mm	10/200	0.5/11.0
98-789	17 mm	38 mm	10/200	0.7/14.5
98-790	18 mm	38 mm	10/200	0.9/18.6
98-791	19 mm	38 mm	10/200	0.8/15.4
98-792	20 mm	38 mm	10/200	1.0/20.4
98-793	21 mm	38 mm	10/200	0.9/18.5
98-794	22 mm	38 mm	10/200	0.9/18.0
98-795	23 mm	38 mm	10/200	1.1/21.7
98-796	24 mm	38 mm	10/200	1.0/19.9
98-797	25 mm	42 mm	10/100	1.3/13.7
98-798	26 mm	42 mm	10/100	1.3/13.1
98-799	27 mm	42 mm	10/100	1.4/14.7
98-800	28 mm	42 mm	10/100	1.6/16.9
98-801	29 mm	42 mm	10/100	1.6/16.1
98-802	30 mm	44 mm	10/100	1.8/18.9
98-804	31 mm	44 mm	10/100	2.0/21.0
98-803	32 mm	44 mm	10/100	2.4/24.0





1/2" Drive Standard - 12 Point Sockets (SAE)

Item No.	Size (A)	Length		 kgs
96-460	5/16"	38 mm	10/200	0.5/10.9
96-461	3/8"	38 mm	10/200	0.5/10.4
96-462	7/16"	38 mm	10/200	0.5/10.6
96-463	1/2"	38 mm	10/200	0.6/11.5
96-464	9/16"	38 mm	10/200	0.5/11.1
98-815	5/8"	38 mm	10/200	0.5/11.1
98-816	11/16"	38 mm	10/200	0.7/14.5
98-817	3/4"	38 mm	10/200	0.8/15.6
98-818	13/16"	38 mm	10/200	0.9/19.0
98-819	7/8"	38 mm	10/200	0.9/17.8
98-820	15/16"	38 mm	10/200	1.0/21.3
98-821	1"	42 mm	10/100	1.4/14.0
98-822	1-1/16"	42 mm	10/100	1.4/14.4
96-496	1-1/8"	42 mm	10/100	1.5/15.8
98-823	1-3/16"	44 mm	10/100	1.9/19.3
98-824	1-1/4"	44 mm	10/100	2.0/20.8



1/2" Drive

1/2" Drive Deep - 6 Point Sockets (Metric)

Item No.	Size (A)	Length		 kgs
96-416	8 mm	77 mm	12/144	1.5/18.3
96-417	9 mm	77 mm	12/144	1.3/15.8
96-418	10 mm	77 mm	12/144	1.3/16.2
96-419	11 mm	77 mm	12/144	1.3/15.5
96-420	12 mm	77 mm	12/144	1.4/17.2
96-421	13 mm	77 mm	12/144	1.5/17.9
96-422	14 mm	77 mm	12/144	1.4/17.5
96-423	15 mm	77 mm	12/144	1.4/17.7
96-424	16 mm	77 mm	12/144	1.4/16.9
96-425	17 mm	77 mm	12/120	1.8/18.3
96-426	18 mm	77 mm	12/120	2.2/22.6
96-427	19 mm	77 mm	12/120	2.0/20.3
96-428	20 mm	77 mm	12/120	2.5/25.0
96-429	21 mm	77 mm	12/120	2.2/22.6
96-430	22 mm	77 mm	12/72	2.8/17.1
96-431	23 mm	77 mm	12/72	3.2/19.7
96-432	24 mm	77 mm	12/72	3.2/19.5
96-433	25 mm	77 mm	12/72	3.6/22.1
96-434	26 mm	77 mm	12/72	3.5/21.6
96-435	27 mm	77 mm	12/48	4.0/16.5
96-436	28 mm	77 mm	12/48	4.7/19.2
96-438	30 mm	77 mm	12/48	4.6/18.8
96-439	32 mm	77 mm	12/48	5.7/23.1



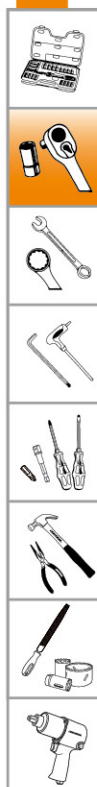

1/2" Drive Deep - 6 Point Sockets (SAE)

Item No.	Size (A)	Length		 kgs
96-479	3/8"	77 mm	12/144	1.3/16.2
96-480	7/16"	77 mm	12/144	1.3/15.5
96-481	1/2"	77 mm	12/144	1.5/17.9
96-482	9/16"	77 mm	12/144	1.5/17.8
96-483	5/8"	77 mm	12/144	1.5/17.8
96-484	11/16"	77 mm	12/120	1.6/16.0
96-485	3/4"	77 mm	12/120	2.0/20.6
96-486	13/16"	77 mm	12/120	2.2/22.6
96-487	7/8"	77 mm	12/72	2.8/17.1
96-488	15/16"	77 mm	12/72	3.2/19.5
96-489	1"	77 mm	12/72	3.6/22.1
96-490	1-1/16"	77 mm	12/48	4.0/16.5
96-491	1-1/8"	77 mm	12/48	4.6/18.8
96-497	1-1/4"	77 mm	12/48	5.7/23.1



1/2" Drive

1/2" Drive Deep - 12 Point Sockets (Metric)

Item No.	Size (A)	Length		 kgs
96-716	8 mm	77 mm	12/144	1.5/18.3
96-717	9 mm	77 mm	12/144	1.3/15.8
96-718	10 mm	77 mm	12/144	1.3/16.2
96-719	11 mm	77 mm	12/144	1.3/15.5
96-720	12 mm	77 mm	12/144	1.4/17.2
96-721	13 mm	77 mm	12/144	1.5/17.9
96-722	14 mm	77 mm	12/144	1.4/17.5
96-723	15 mm	77 mm	12/144	1.4/17.7
96-724	16 mm	77 mm	12/144	1.4/16.9
96-725	17 mm	77 mm	12/120	1.8/18.3
96-726	18 mm	77 mm	12/120	2.2/22.6
96-727	19 mm	77 mm	12/120	2.0/20.3
96-728	20 mm	77 mm	12/120	2.5/25.0
96-729	21 mm	77 mm	12/120	2.2/22.6
96-730	22 mm	77 mm	12/72	2.8/17.1
96-731	23 mm	77 mm	12/72	3.2/19.7
96-732	24 mm	77 mm	12/72	3.2/19.5
96-735	27 mm	77 mm	12/48	4.2/16.5
96-738	30 mm	77 mm	12/48	4.6/18.8
96-739	32 mm	77 mm	12/48	5.7/23.1



1/2" Drive Deep - 12 Point Sockets (SAE)

Item No.	Size (A)	Length		 kgs
96-550	3/8"	77 mm	12/144	1.3/16.2
96-551	7/16"	77 mm	12/144	1.3/15.5
96-552	1/2"	77 mm	12/144	1.5/17.9
96-553	9/16"	77 mm	12/144	1.5/17.8
96-554	5/8"	77 mm	12/144	1.5/17.8
96-555	11/16"	77 mm	12/120	1.6/16.0
96-556	3/4"	77 mm	12/120	2.0/20.6
96-557	13/16"	77 mm	12/120	2.2/22.6
96-558	7/8"	77 mm	12/72	2.8/17.1
96-559	15/16"	77 mm	12/72	3.2/19.5
96-560	1"	77 mm	12/72	3.6/22.1
96-561	1-1/16"	77 mm	12/48	4.0/16.5
96-562	1-1/8"	77 mm	12/48	4.6/18.8
96-563	1-1/4"	77 mm	12/48	5.7/23.1



1/2" Drive

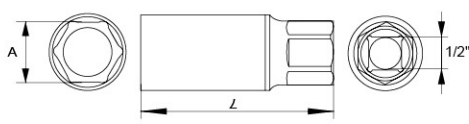

1/2" Drive Spark Plug Sockets

Item No.	Size (A)	Length		kgs
96-580	16 mm (5/8")	65 mm	10/100	1.0/10.3
96-585	18 mm (23/32")	67 mm	10/100	1.5/15.0
96-581	21 mm (13/16")	67 mm	10/100	1.5/15.4

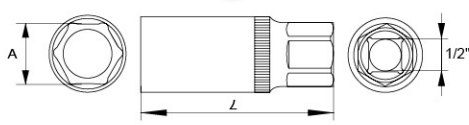

1/2" Drive Spark Plug Sockets-Magnetic

Item No.	Size (A)	Length		kgs
96-582	16 mm (5/8")	65 mm	10/100	1.1/11.7
96-584	18 mm (23/32")	67 mm	10/100	1.5/15.0
96-583	21 mm (13/16")	67 mm	10/100	1.6/15.9

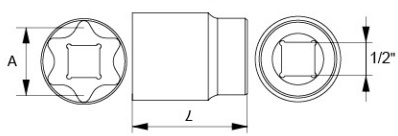

1/2" Drive E-Sockets (For TORX[®] Head Screws)

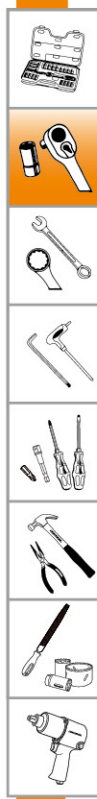

Item No.	Size (A)	Length		kgs
93-503	E10	38 mm	10/200	0.5/10.9
93-504	E11	38 mm	10/200	0.5/10.9
93-505	E12	38 mm	10/200	0.5/11.2
93-507	E14	38 mm	10/200	0.5/11.2
93-509	E16	38 mm	10/200	0.6/11.5
93-511	E18	38 mm	10/200	0.7/14.7
93-513	E20	38 mm	10/200	0.7/14.9
93-515	E22	38 mm	10/200	0.8/17.0
93-517	E24	38 mm	10/200	1.1/21.6



1/2" Drive



■ **1/2" Drive Phillips Bit Sockets**

Item No.	Size	Length		 kgs
99-102	PH2	60 mm	12/240	0.9/17.6
99-103	PH3	60 mm	12/240	0.9/17.6
99-104	PH4	60 mm	12/240	0.9/17.8



■ **1/2" Drive Slotted Bit Sockets**

Item No.	Size	Length		 kgs
99-268	8 mm	60 mm	12/240	0.9/17.9
99-270	10 mm	60 mm	12/240	1.0/20.0
99-272	12 mm	60 mm	12/240	1.2/24.0
99-274	14 mm	60 mm	12/240	1.2/25.1





■ **1/2" Drive Hex Bit Sockets (Metric)**

Item No.	Size	Length		 kgs
99-113	3 mm	60 mm	12/240	0.9/17.5
99-114	4 mm	60 mm	12/240	0.9/17.5
99-115	5 mm	60 mm	12/240	0.9/17.6
99-188	6 mm	60 mm	12/240	0.9/17.9
99-117	7 mm	60 mm	12/240	0.9/18.6
99-189	8 mm	60 mm	12/240	0.9/18.6
99-190	10 mm	60 mm	12/240	1.0/20.0
99-191	12 mm	60 mm	12/240	1.1/23.1
99-192	14 mm	60 mm	12/240	1.2/24.9
99-193	17 mm	60 mm	12/120	2.0/19.8
99-194	19 mm	60 mm	12/96	2.8/21.7



■ **1/2" Drive Hex Bit Sockets (SAE)**

Item No.	Size	Length		 kgs
99-180	5/16"	60 mm	12/240	0.9/18.3
99-181	3/8"	60 mm	12/240	1.0/20.0
99-182	7/16"	60 mm	12/240	1.2/22.3
99-183	1/2"	60 mm	12/240	1.2/23.4
99-184	9/16"	60 mm	12/120	1.7/17.5
99-185	5/8"	60 mm	12/120	1.8/18.3



1/2" Drive

1/2" Drive Deep Hex Bit Sockets (Metric)



Item No.	Size	Length		 kgs
99-118	3 mm	80 mm	12/240	0.9/19.5
99-119	4 mm	80 mm	12/240	0.9/19.5
99-200	5 mm	80 mm	12/240	1.0/19.5
99-201	6 mm	80 mm	12/240	1.0/19.8
99-202	7 mm	80 mm	12/240	1.0/20.1
99-203	8 mm	80 mm	12/240	1.0/20.3
99-204	10 mm	80 mm	12/240	1.1/23.4
99-205	12 mm	80 mm	12/144	1.4/16.9
99-120	14 mm	80 mm	12/120	1.6/15.9
99-121	17 mm	80 mm	12/120	2.2/22.6
99-122	19 mm	80 mm	12/96	2.7/22.1

1/2" Drive TORX[®] Bit Sockets



Item No.	Size	Length		 kgs
99-215	T-20	60 mm	12/240	0.8/17.3
99-216	T-25	60 mm	12/240	0.8/17.4
99-217	T-27	60 mm	12/240	0.8/17.5
99-218	T-30	60 mm	12/240	0.8/17.5
99-219	T-40	60 mm	12/240	0.9/17.6
99-230	T-45	60 mm	12/240	0.9/17.9
99-231	T-50	60 mm	12/240	0.9/18.0
99-232	T-55	60 mm	12/240	1.0/21.0
99-233	T-60	60 mm	12/240	1.2/23.6

1/2" Drive TORX[®] Deep Bit Sockets



Item No.	Size	Length		 kgs
99-123	T-20	80 mm	12/144	0.9/11.6
99-124	T-25	80 mm	12/144	1.0/11.9
99-125	T-27	80 mm	12/144	1.0/11.9
99-126	T-30	80 mm	12/144	1.0/11.9
99-127	T-40	80 mm	12/144	1.0/11.9
99-128	T-45	80 mm	12/144	1.0/12.2
99-129	T-50	80 mm	12/144	1.0/12.2
99-130	T-55	80 mm	12/144	1.2/14.4
99-131	T-60	80 mm	12/144	1.4/17.0



1/2" Drive

■ **1/2" Drive TORX® Tamper Proof Bit Sockets**

Item No.	Size	Length		 kgs
99-243	T-20	60 mm	12/240	0.8/17.5
99-244	T-25	60 mm	12/240	0.9/17.9
99-245	T-27	60 mm	12/240	0.9/17.9
99-246	T-30	60 mm	12/240	0.9/17.9
99-247	T-40	60 mm	12/240	0.9/17.9
99-248	T-45	60 mm	12/240	0.9/17.9
99-249	T-50	60 mm	12/240	0.9/18.1
99-250	T-55	60 mm	12/240	1.0/20.8
99-251	T-60	60 mm	12/240	1.1/22.0



■ **1/2" Drive TORX® Deep Tamper Proof Bit Sockets**

Item No.	Size	Length		 kgs
99-163	T-20	80 mm	12/144	0.9/11.6
99-164	T-25	80 mm	12/144	1.0/11.9
99-165	T-27	80 mm	12/144	1.0/11.9
99-166	T-30	80 mm	12/144	1.0/11.9
99-167	T-40	80 mm	12/144	1.0/11.9
99-168	T-45	80 mm	12/144	1.0/12.2
99-169	T-50	80 mm	12/144	1.0/12.2
99-170	T-55	80 mm	12/144	1.2/14.4
99-171	T-60	80 mm	12/144	1.4/17.0



■ **1/2" Drive POZIDRIV® Bit Sockets**

Item No.	Size	Length		 kgs
99-107	PZ2	60 mm	12/240	0.9/17.6
99-108	PZ3	60 mm	12/240	0.9/17.6
99-109	PZ4	60 mm	12/240	0.9/17.8



3/4" Drive

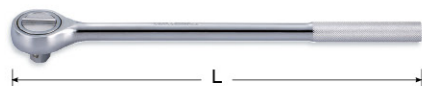

Ratchet (Round Head)

Item No.	Size (L)			kgs
99-302	20" 43 Teeth	1/8		2.4/20.0



Quick Release Ratchet (Round Head)

Item No.	Size (L)			kgs
98-907	20" 43 Teeth	1/8		2.5/20.7



Quick Release Ratchet (Extendable)

Item No.	Size (L)			kgs
98-910	20" - 33" 43 Teeth	1/4		3.5/15.0
98-911	28" - 44" 43 Teeth	1/4		4.5/19.5



Quick Release Ratchet (Pear Head)

Item No.	Size (L)			kgs
98-909	20" 24 Teeth	1/8		2.2/20.8
98-908	25" 24 Teeth	1/4		2.4/11.6



Flex Handles

Item No.	Size (L)			kgs
99-303	18"	1/8		1.9/16.2
99-310	20"	1/8		2.0/16.6
99-312	24"	1/8		2.4/9.8



Quick Release Flex Handle

Item No.	Size (L)			kgs
99-370	20"	1/8		2.1/17.0

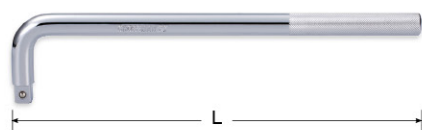

"L" knurled Handle

Item No.	Size (L)			kgs
99-315	18"	1/10		1.9/19.2
99-313	24"	1/10		2.4/25.0

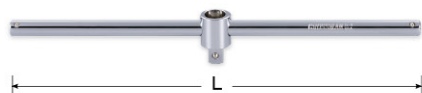

Sliding "T" Bars

Item No.	Size (L)			kgs
99-304	18"	1/10		1.5/16.6
99-305	20"	1/8		1.5/12.8

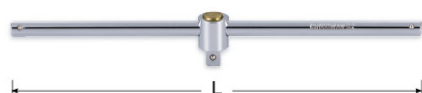

Quick Release Sliding "T" Bars

Item No.	Size (L)			kgs
99-301	18"	1/8		1.9/12.3
99-311	20"	1/8		1.5/12.9

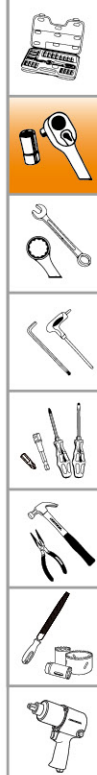

3/4" Drive



Extensions

Item No.	Size (L)		kgs
99-306	4"	6/36	2.6/16.2
99-309	6"	6/24	3.9/16.1
99-307	8"	6/24	5.0/20.2
99-308	16"	3/12	4.8/19.8

Quick Release Extensions

Item No.	Size (L)		kgs
99-356	4"	6/36	2.8/16.9
99-357	8"	6/24	5.2/21.1
99-358	16"	3/12	4.8/20.0

Socket Drive Adapter

Item No.	Size		kgs
99-909	3/4"F x 1/2"M	6/36	1.2/7.8

Universal Joint



Item No.	Size (L)		kgs
99-911	4"	6/36	3.4/21.0

3/4" Drive Standard - 6 Point Sockets (Metric)

Item No.	Size (A)	Length		kgs
99-317	17 mm	50 mm	10/80	1.9/15.4
99-319	19 mm	50 mm	10/80	1.9/15.4
99-321	21 mm	50 mm	10/80	1.9/15.4
99-322	22 mm	50 mm	10/80	2.2/18.3
99-323	23 mm	50 mm	10/80	2.2/18.4
99-324	24 mm	51 mm	10/80	2.3/19.0
99-325	25 mm	52 mm	10/80	2.4/19.6
99-326	26 mm	52 mm	10/80	2.6/21.3
99-327	27 mm	52 mm	10/80	2.6/21.3
99-328	28 mm	52 mm	10/80	2.7/22.1
99-329	29 mm	54 mm	6/36	1.6/10.0
99-330	30 mm	56 mm	6/36	1.8/11.0
99-331	31 mm	56 mm	6/36	2.0/12.6
99-332	32 mm	56 mm	6/36	2.0/12.6
99-333	33 mm	56 mm	6/36	2.1/13.0
99-334	34 mm	56 mm	6/36	2.1/13.0
99-335	35 mm	58 mm	6/36	2.5/15.6
99-336	36 mm	58 mm	6/36	2.6/16.2
99-337	37 mm	58 mm	6/36	3.1/19.1
99-338	38 mm	60 mm	6/36	3.1/19.1
99-339	39 mm	62 mm	24	12.9
99-340	40 mm	62 mm	24	12.9



3/4" Drive

3/4" Drive Standard - 6 Point Sockets (Metric)

Item No.	Size (A)	Length		 kgs
99-341	41 mm	64 mm	24	13.9
99-342	42 mm	64 mm	24	14.2
99-343	43 mm	65 mm	24	14.8
99-344	44 mm	66 mm	24	15.9
99-345	45 mm	66 mm	24	15.9
99-346	46 mm	68 mm	20	14.4
99-347	47 mm	70 mm	20	15.2
99-348	48 mm	70 mm	20	15.2
99-350	50 mm	72 mm	20	17.2
99-354	54 mm	72 mm	12	11.1
99-355	55 mm	76 mm	12	11.9
99-256	56 mm	76 mm	12	12.9
99-360	60 mm	78 mm	12	13.4
99-363	63 mm	80 mm	8	10.3
99-365	65 mm	82 mm	8	12.1





3/4" Drive Standard - 6 Point Sockets (SAE)

Item No.	Size (A)	Length		 kgs
99-661	3/4"	50 mm	10/80	2.1/17.6
99-662	13/16"	50 mm	10/80	2.1/17.6
99-663	7/8"	50 mm	10/80	2.2/18.3
99-664	15/16"	51 mm	10/80	2.2/18.4
99-665	1"	52 mm	10/80	2.3/19.0
99-666	1-1/16"	52 mm	10/80	2.3/19.0
99-667	1-1/8"	52 mm	6/36	1.6/10.1
99-668	1-3/16"	54 mm	6/36	1.8/11.0
99-669	1-1/4"	56 mm	6/36	1.9/11.6
99-670	1-5/16"	56 mm	6/36	2.1/12.7
99-671	1-3/8"	58 mm	6/36	2.4/15.0
99-672	1-7/16"	60 mm	6/36	2.6/15.9
99-673	1-1/2"	60 mm	6/36	2.8/17.4
99-680	1-9/16"	62 mm	24	12.9
99-674	1-5/8"	64 mm	24	13.5
99-675	1-11/16"	64 mm	24	14.1
99-676	1-3/4"	66 mm	24	16.4
99-677	1-13/16"	68 mm	20	14.7
99-678	1-7/8"	70 mm	20	14.7
99-679	2"	72 mm	20	16.2
98-960	2-1/4"	76 mm	12	11.6
98-961	2-3/8"	78 mm	8	9.2
98-962	2-1/2"	80 mm	8	10.3
98-963	2-3/4"	86 mm	4	7.1



3/4" Drive

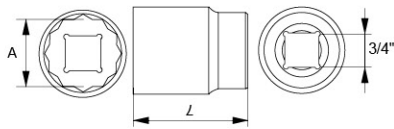

3/4" Drive Standard - 12 Point Sockets (Metric)

Item No.	Size (A)	Length	 	 kgs
93-317	17 mm	50 mm	10/80	1.9/15.4
93-319	19 mm	50 mm	10/80	1.9/15.4
93-321	21 mm	50 mm	10/80	1.9/15.4
93-322	22 mm	50 mm	10/80	2.2/18.3
93-323	23 mm	50 mm	10/80	2.2/18.4
93-324	24 mm	51 mm	10/80	2.3/19.0
93-325	25 mm	52 mm	10/80	2.4/19.6
93-326	26 mm	52 mm	10/80	2.6/21.3
93-327	27 mm	52 mm	10/80	2.6/21.3
93-328	28 mm	52 mm	10/80	2.7/22.1
93-329	29 mm	52 mm	6/36	1.6/10.0
93-330	30 mm	54 mm	6/36	1.8/11.0
93-331	31 mm	54 mm	6/36	2.0/12.6
93-332	32 mm	56 mm	6/36	2.0/12.6
93-333	33 mm	56 mm	6/36	2.0/12.6
93-334	34 mm	56 mm	6/36	2.1/13.0
93-335	35 mm	58 mm	6/36	2.1/13.0
93-336	36 mm	58 mm	6/36	2.5/15.6
93-337	37 mm	60 mm	6/36	2.6/16.2
93-338	38 mm	60 mm	6/36	2.6/16.2
93-339	39 mm	62 mm	6/36	3.2/16.0
93-340	40 mm	62 mm	6/36	13.9
93-341	41 mm	62 mm	24	13.9
93-343	43 mm	62 mm	24	14.1
93-344	44 mm	62 mm	24	14.6
93-345	45 mm	62 mm	24	14.4
93-346	46 mm	70 mm	20	14.4
93-347	47 mm	70 mm	20	15.0
93-350	50 mm	72 mm	20	17.2
93-354	54 mm	72 mm	12	11.1
93-355	55 mm	76 mm	12	11.9
93-356	56 mm	76 mm	12	12.9
93-360	60 mm	78 mm	12	13.4
93-363	63 mm	80 mm	8	10.3
93-365	65 mm	82 mm	8	12.1



3/4" Drive

3/4" Drive Standard - 12 Point Sockets (SAE)

Item No.	Size (A)	Length		 kgs
93-661	3/4"	50 mm	10/80	2.1/17.6
93-662	13/16"	50 mm	10/80	2.1/17.6
93-663	7/8"	50 mm	10/80	2.2/18.3
93-664	15/16"	51 mm	10/80	2.2/18.4
93-665	1"	52 mm	10/80	2.3/19.0
93-666	1-1/16"	52 mm	10/80	2.3/19.0
93-667	1-1/8"	52 mm	6/36	1.6/10.1
93-668	1-3/16"	54 mm	6/36	1.8/11.0
93-669	1-1/4"	56 mm	6/36	1.9/11.6
93-670	1-5/16"	56 mm	6/36	2.1/12.7
93-671	1-3/8"	58 mm	6/36	2.4/15.0
93-672	1-7/16"	60 mm	6/36	2.6/15.9
93-673	1-1/2"	60 mm	6/36	2.8/17.4
93-680	1-9/16"	62 mm	24	12.9
93-674	1-5/8"	64 mm	24	13.5
93-675	1-11/16"	64 mm	24	14.1
93-676	1-3/4"	66 mm	24	16.4
93-677	1-13/16"	68 mm	20	14.7
93-678	1-7/8"	70 mm	20	14.7
93-679	2"	72 mm	20	16.2
93-681	2-1/4"	76 mm	12	11.6
93-682	2-3/8"	78 mm	8	9.2
93-683	2-1/2"	80 mm	8	10.3
93-684	2-3/4"	87 mm	4	7.1



1" Drive



Quick Release Ratchet (Extendable)

Item No.	Size (L)			kgs
91-801	500-830 mm	1/5		3.52/18.6
91-802	700-1000 mm	1/5		4.05/20.2



"L" knurled Handle

Item No.	Size (L)			kgs
91-820	26"	1/4		5.1/21.5

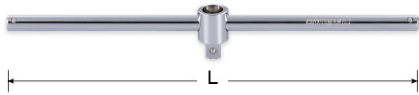

Sliding "T" Bar

Item No.	Size (L)			kgs
96-379	22"	1/5		3.2/16.5

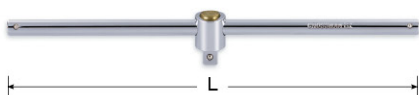

Quick Release Sliding "T" Bar

Item No.	Size (L)			kgs
91-809	22"	1/5		3.3/16.5



Extensions

Item No.	Size (L)			kgs
96-373	8"	1/5		1.35/6.95
91-807	16"	1/5		2.57/12.95



Quick Release Extensions

Item No.	Size (L)			kgs
91-814	8"	1/5		1.47/6.55
91-815	16"	1/5		2.62/13.45



Socket Drive Adapter

Item No.	Size			kgs
91-812	1"F x 3/4"M	1/5		0.45/2.35



3-Function Adapter

Item No.	Size			kgs
91-813	1"F x 1"M	1/5		0.6/3.25



1" Drive



1" Drive Standard - 6 Point Sockets (Metric)

	Size (A)	Length		kgs
91-836	36 mm	65 mm	6/36	0.5/17.8
91-838	38 mm	65 mm	6/36	0.5/19.6
91-841	41 mm	70 mm	26	0.6/15.5
91-846	46 mm	75 mm	20	0.9/17.5
91-850	50 mm	75 mm	18	1.1/19.2
91-854	54 mm	80 mm	16	1.1/18.0
91-855	55 mm	80 mm	14	1.2/17.2
91-858	58 mm	80 mm	14	1.3/18.3
91-860	60 mm	84 mm	14	1.4/19.6
91-863	63 mm	87 mm	12	1.5/18.1
91-865	65 mm	87 mm	12	1.6/18.7
91-867	67 mm	90 mm	12	1.7/20.4
91-870	70 mm	93 mm	10	2.0/20.0
91-871	71 mm	93 mm	10	2.1/20.6
91-875	75 mm	97 mm	8	2.1/17.2
91-877	77 mm	103 mm	8	2.2/17.6
91-880	80 mm	103 mm	8	2.2/18.0

Specialty Sockets



L-Handle Sockets

Item No.	Size	Length		kgs
94-571	8 mm	6"	1/200	0.09/18.0
94-572	10 mm	6"	1/200	0.09/19.2

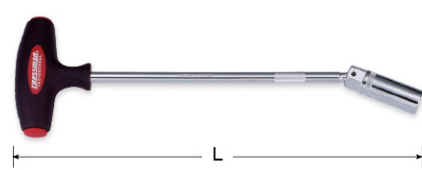

T-Handle Spark Plug Sockets

Item No.	Size	Length		kgs
94-576	16 mm	13-1/2"	6/60	0.4/22.1
94-578	21 mm	13-1/2"	6/60	0.4/25.7

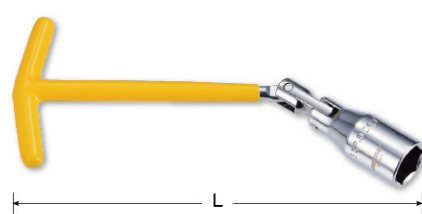

T-Handle Spark Plug Sockets w/o Spring

Item No.	Size	Length		kgs
95-835	16 mm	13-1/2"	6/36	2/12
95-821	21 mm	13-1/2"	6/36	2/12

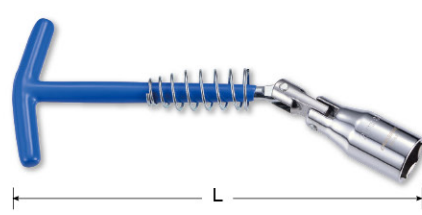

T-Handle Spark Plug Sockets w/spring

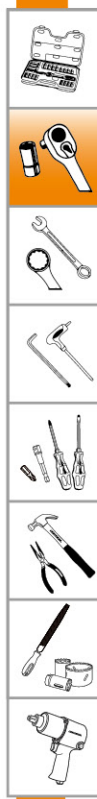

Item No.	Size	Length		kgs
95-836	16 mm	13-1/2"	6/36	2/12
95-831	21 mm	13-1/2"	6/36	2/12





Specialty Sockets

T-Handle Magnetic Spark Plug Sockets

Item No.	Size	Length		 kgs
94-556	16 mm	200 x 450 mm	1/50	0.48/25.2
94-558	18 mm	200 x 450 mm	1/50	0.53/22.5
94-560	21 mm	200 x 450 mm	1/50	0.58/24.2

T-Handle Swivel Sockets (Long Arm) - 6 Point

Item No.	Size	Length		 kgs
94-541	8 mm	200 x 600 mm	1/30	0.52/16.5
94-542	10 mm	200 x 600 mm	1/30	0.53/16.9
94-543	12 mm	200 x 600 mm	1/30	0.53/16.9
94-544	14 mm	200 x 600 mm	1/30	0.53/16.9
94-545	17 mm	200 x 600 mm	1/40	0.54/23.0
94-546	19 mm	200 x 600 mm	1/40	0.54/23.0

T-Handle Standard Sockets - 6 Point

Item No.	Size	Length		 kgs
94-521	8 mm	200 x 250 mm	1/100	0.19/19.6
94-522	10 mm	200 x 250 mm	1/100	0.23/23.7
94-523	12 mm	200 x 300 mm	1/60	0.42/26.4
94-524	14 mm	200 x 300 mm	1/50	0.43/22.2
94-525	17 mm	200 x 300 mm	1/40	0.53/22.0

T-Handle Deep Sockets - 6 Point

Item No.	Size	Length		 kgs
94-561	8 mm	200 x 300 mm	1/80	0.32/26.0
94-562	10 mm	200 x 300 mm	1/80	0.32/26.0
94-563	12 mm	200 x 300 mm	1/80	0.32/26.0
94-564	14 mm	200 x 300 mm	1/80	0.32/26.0
94-565	17 mm	250 x 300 mm	1/40	0.61/25.0
94-566	19 mm	250 x 300 mm	1/40	0.61/25.0



Torque Wrench

Torque Wrench



Item No.	Drive	Size (L)		kgs
97-921	1/4"	14"(250 In-LB)	1/20	1.0/20.2
97-941	3/8"	14"(250 In-LB)	1/20	1.0/20.2
97-942	3/8"	15"(80 Ft-LB)	1/12	1.2/15.3
97-951	1/2"	25"(250 Ft-LB)	1/6	3.0/18.9
97-966	3/4"	34"(400 Ft-LB)	1/4	4.3/17.7
97-962	3/4"	43"(600 Ft-LB)	1/4	6.7/27.5

** Accuracy Rate: Forward \pm 4%, Reverse \pm 6%.

Torque Wrench



Item No.	Drive	Size (L)		kgs
97-922	1/4"	11"(200 In-LB)	1/20	0.8/15.7
97-944	3/8"	11"(200 In-LB)	1/20	0.8/15.7
97-943	3/8"	14"(80 Ft-LB)	1/20	1.1/22.5
97-950	1/2"	18"(150 Ft-LB)	1/10	1.7/17.8

** Accuracy Rate: Forward \pm 4%, Reverse \pm 6%.

Torque Wrench



Item No.	Drive	Size (L)		kgs
97-981	1/4"	11"(5~25 Nm)	1/20	0.42/8.4
97-982	3/8"	14"(10~50 Nm)	1/20	0.92/18.4
97-983	3/8"	16"(20~100 Nm)	1/12	1.02/12.24
97-984	1/2"	20"(40~200 Nm)	1/12	1.2/14.4
97-985	1/2"	23"(60~300 Nm)	1/12	1.33/15.96
97-986	1/2"	27"(80~400 Nm)	1/6	1.82/10.92
97-987	3/4"	38"(110~550 Nm)	1/6	3.7/22.2
97-988	3/4"	45"(150~750 Nm)	1/4	5.6/22.4
97-989	1"	49"(200~1000 Nm)	1/2	7.2/14.4

** Ideal For Industrial Use.

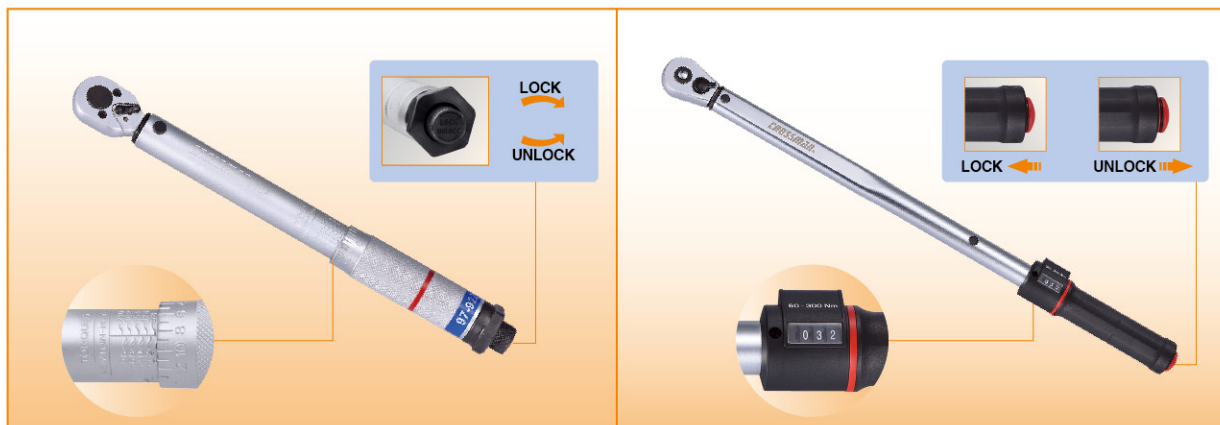

3/8" Impact Socket

■ **3/8" Drive Impact Sockets (Metric)**

Item No.	Size (A)	Length		 kgs
73-106	6 mm	30 mm	10/200	0.4/7.5
73-107	7 mm	30 mm	10/200	0.4/7.5
73-108	8 mm	30 mm	10/200	0.4/7.5
73-109	9 mm	30 mm	10/200	0.4/7.5
73-110	10 mm	30 mm	10/200	0.4/7.7
73-111	11 mm	30 mm	10/200	0.4/8.1
73-112	12 mm	30 mm	10/200	0.4/8.1
73-113	13 mm	30 mm	10/200	0.5/10.3
73-114	14 mm	30 mm	10/200	0.5/10.3
73-115	15 mm	30 mm	10/200	0.5/11.1
73-116	16 mm	30 mm	10/200	0.6/11.9
73-117	17 mm	30 mm	10/200	0.6/12.6
73-118	18 mm	30 mm	10/200	0.7/14.2
73-119	19 mm	30 mm	10/200	0.8/15.8
73-120	20 mm	30 mm	10/200	0.8/15.8
73-121	21 mm	30 mm	10/200	0.8/15.8
73-122	22 mm	30 mm	10/200	0.9/18.4



■ **3/8" Drive Impact Sockets (SAE)**

Item No.	Size (A)	Length		 kgs
73-205	5/16"	30 mm	10/200	0.4/7.5
73-206	3/8"	30 mm	10/200	0.4/7.7
73-207	7/16"	30 mm	10/200	0.4/8.1
73-208	1/2"	30 mm	10/200	0.5/10.3
73-209	9/16"	30 mm	10/200	0.5/10.3
73-210	5/8"	30 mm	10/200	0.6/11.9
73-211	11/16"	30 mm	10/200	0.6/12.6
73-212	3/4"	30 mm	10/200	0.8/15.8
73-213	13/16"	30 mm	10/200	0.8/15.8
73-214	7/8"	30 mm	10/200	0.9/18.8





3/8" Impact Socket

3/8" Drive Deep Impact Sockets (Metric)

Item No.	Size (A)	Length		 kgs
73-306	6 mm	65 mm	15/300	1.2/23.6
73-307	7 mm	65 mm	15/300	1.2/23.6
73-308	8 mm	65 mm	15/300	1.2/23.6
73-309	9 mm	65 mm	15/300	1.2/23.6
73-310	10 mm	65 mm	15/300	1.2/23.6
73-311	11 mm	65 mm	15/300	1.2/23.6
73-312	12 mm	65 mm	15/300	1.2/25.1
73-313	13 mm	65 mm	12/192	1.3/21.3
73-314	14 mm	65 mm	12/192	1.3/21.3
73-315	15 mm	65 mm	12/192	1.4/22.3
73-316	16 mm	65 mm	12/192	1.6/25.2
73-317	17 mm	65 mm	12/96	1.6/13.0
73-318	18 mm	65 mm	12/96	1.7/13.9
73-319	19 mm	65 mm	12/96	2.1/16.8
73-320	20 mm	65 mm	12/96	2.7/22.1
73-321	21 mm	65 mm	12/96	2.8/23.0
73-322	22 mm	65 mm	12/96	3.0/24.0



3/8" Drive Deep Impact Sockets (SAE)

Item No.	Size (A)	Length		 kgs
73-405	5/16"	65 mm	15/300	1.2/23.6
73-406	3/8"	65 mm	15/300	1.2/23.6
73-407	7/16"	65 mm	15/300	1.2/23.6
73-408	1/2"	65 mm	12/192	1.3/21.3
73-409	9/16"	65 mm	12/192	1.3/21.3
73-410	5/8"	65 mm	12/192	1.6/25.2
73-411	11/16"	65 mm	12/96	1.6/13.0
73-412	3/4"	65 mm	12/96	2.1/16.8
73-413	13/16"	65 mm	12/96	2.8/23.0
73-414	7/8"	65 mm	12/96	3.0/24.0



3/8" Drive Hex Head Impact Sockets (Metric)

Item No.	Size	Length		 kgs
73-604	4 mm	60 mm	10/200	0.5/11.1
73-605	5 mm	60 mm	10/200	0.5/11.1
73-606	6 mm	60 mm	10/200	0.7/14.1
73-607	7 mm	60 mm	10/200	0.8/16.1
73-608	8 mm	60 mm	10/200	0.8/17.1
73-609	9 mm	60 mm	10/200	0.9/18.1
73-610	10 mm	60 mm	10/200	0.9/19.1
73-611	11 mm	60 mm	10/200	0.9/19.1
73-612	12 mm	60 mm	10/200	1.0/20.1
73-613	13 mm	60 mm	10/200	1.0/21.1
73-614	14 mm	60 mm	10/200	1.1/23.1
73-615	15 mm	60 mm	10/200	1.2/24.1
73-616	16 mm	60 mm	10/200	1.2/25.1
73-617	17 mm	60 mm	10/200	1.3/26.8

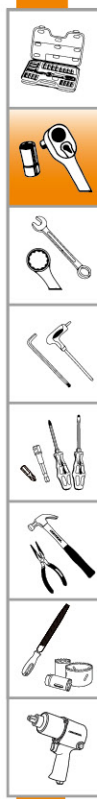
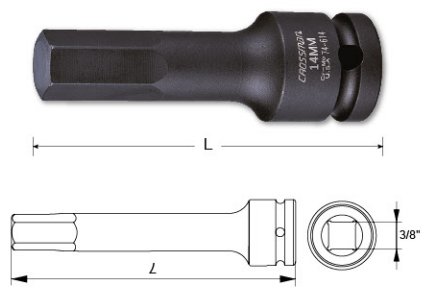

3/8" Impact Socket

3/8" Drive Hex Head Impact Sockets (SAE)

Item No.	Size	Length		 kgs
73-625	5/32"	60 mm	10/200	0.5/11.1
73-626	3/16"	60 mm	10/200	0.5/11.1
73-627	7/32"	60 mm	10/200	0.6/11.5
73-628	1/4"	60 mm	10/200	0.7/15.1
73-629	5/16"	60 mm	10/200	0.8/17.1
73-630	3/8"	60 mm	10/200	0.9/19.1
73-631	7/16"	60 mm	10/200	0.9/19.1
73-632	1/2"	60 mm	10/200	1.0/21.1
73-633	9/16"	60 mm	10/200	1.2/24.1
73-634	5/8"	60 mm	10/200	1.2/25.1

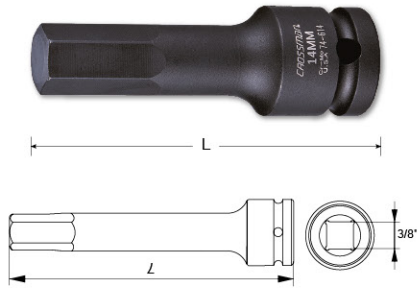

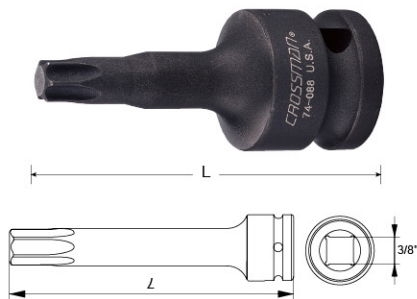

3/8" Drive TORX® Impact Sockets

Item No.	Size	Length		 kgs
73-640	T10	52 mm	10/200	0.5/11.1
73-641	T15	52 mm	10/200	0.5/11.1
73-642	T20	52 mm	10/200	0.7/14.1
73-643	T25	52 mm	10/200	0.8/16.1
73-644	T27	52 mm	10/200	0.8/16.1
73-645	T30	52 mm	10/200	0.9/18.1
73-646	T40	52 mm	10/200	0.9/19.1
74-647	T45	52 mm	10/200	0.9/19.1
74-648	T50	52 mm	10/200	1.0/20.1
74-649	T55	52 mm	10/200	1.0/20.1
74-650	T60	52 mm	10/200	1.1/23.1





3/8" Socket Drive Impact Adapters

Item No.	Size		 kgs
73-004	3/8"F x 1/4"M	10/60	0.3/2.1
73-005	3/8"F x 1/2"M	10/100	0.7/7.4



3/8" Drive Impact Extensions

Item No.	Size (L)		 kgs
73-703	3"	20/200	1.8/18.7
73-704	6"	15/150	2.4/24.2





3/8" Drive Impact Universal Joint

Item No.	Size		 kgs
73-906	51 mm	20/200	2.2/22.2



1/2" Impact Socket

1/2" Drive Impact Sockets (Metric)

Item No.	Size (A)	Length		 kgs
74-108	8 mm	38 mm	10/300	0.7/22.9
74-109	9 mm	38 mm	10/300	0.7/22.9
74-110	10 mm	38 mm	10/300	0.7/22.9
74-111	11 mm	38 mm	10/300	0.7/22.9
74-112	12 mm	38 mm	10/300	0.7/22.9
74-113	13 mm	38 mm	10/300	0.8/24.4
74-114	14 mm	38 mm	10/300	0.8/25.9
74-115	15 mm	38 mm	10/200	1.2/23.8
74-116	16 mm	38 mm	10/200	1.2/23.8
74-117	17 mm	40 mm	10/200	1.3/25.5
74-118	18 mm	40 mm	10/200	1.3/25.5
74-119	19 mm	40 mm	10/200	1.3/25.5
74-120	20 mm	40 mm	10/200	1.3/25.5
74-121	21 mm	40 mm	10/200	1.3/25.5
74-122	22 mm	40 mm	10/160	1.3/21.8
74-123	23 mm	42 mm	10/160	1.3/22.0
74-124	24 mm	42 mm	10/160	1.4/23.2
74-125	25 mm	42 mm	10/160	1.5/24.0
74-126	26 mm	42 mm	10/160	1.5/24.0
74-127	27 mm	42 mm	10/80	1.9/15.6
74-128	28 mm	45 mm	10/80	2.1/17.2
74-129	29 mm	45 mm	10/80	2.1/17.2
74-130	30 mm	46 mm	10/80	2.2/18.0
74-132	32 mm	46 mm	6/36	1.4/8.5





1/2" Drive Impact Sockets (SAE)

Item No.	Size (A)	Length		 kgs
74-205	5/16"	38 mm	10/300	0.7/22.9
74-206	3/8"	38 mm	10/300	0.7/22.9
74-207	7/16"	38 mm	10/300	0.7/22.9
74-208	1/2"	38 mm	10/200	0.8/16.5
74-209	9/16"	38 mm	10/200	0.9/17.5
74-210	5/8"	38 mm	10/200	1.2/24.5
74-211	11/16"	40 mm	10/200	1.2/25.5
74-212	3/4"	40 mm	10/200	1.3/25.5
74-213	13/16"	40 mm	10/200	1.3/25.5
74-214	7/8"	40 mm	10/160	1.4/22.1
74-215	15/16"	42 mm	10/160	1.4/23.2
74-216	1"	42 mm	10/160	1.5/24.0
74-217	1-1/16"	42 mm	10/80	1.9/15.6
74-218	1-1/8"	45 mm	10/80	2.1/17.2
74-219	1-3/16"	46 mm	10/80	2.2/18.0
74-220	1-1/4"	46 mm	6/36	1.4/8.9



1/2" Impact Socket

1/2" Drive Deep Impact Sockets (Metric)

Item No.	Size (A)	Length		 kgs
74-308	8 mm	78 mm	12/96	2.0/16.1
74-309	9 mm	78 mm	12/96	2.0/16.1
74-310	10 mm	78 mm	12/96	2.0/16.1
74-311	11 mm	78 mm	12/96	2.0/16.1
74-312	12 mm	78 mm	12/96	2.0/16.1
74-313	13 mm	78 mm	12/96	2.2/18.0
74-314	14 mm	78 mm	12/96	2.2/18.0
74-315	15 mm	78 mm	12/96	2.6/20.9
74-316	16 mm	78 mm	12/96	2.6/20.9
74-317	17 mm	78 mm	12/96	2.7/22.1
74-318	18 mm	78 mm	12/96	2.7/22.1
74-319	19 mm	78 mm	12/96	2.7/22.1
74-320	20 mm	78 mm	12/96	2.7/22.1
74-321	21 mm	78 mm	12/96	2.7/22.1
74-322	22 mm	78 mm	10/80	2.4/19.4
74-323	23 mm	78 mm	6/48	1.5/12.0
74-324	24 mm	78 mm	6/48	1.9/15.8
74-325	25 mm	78 mm	6/48	2.1/17.3
74-326	26 mm	78 mm	6/48	2.1/17.3
74-327	27 mm	78 mm	6/48	2.5/20.6
74-328	28 mm	78 mm	6/48	2.5/20.6
74-329	29 mm	78 mm	6/48	2.5/20.6
74-330	30 mm	78 mm	6/48	2.5/20.6
74-332	32 mm	78 mm	5/40	2.2/18.2



1/2" Drive Deep Impact Sockets (SAE)

Item No.	Size (A)	Length		 kgs
74-405	5/16"	78 mm	12/96	2.0/16.1
74-406	3/8"	78 mm	12/96	2.0/16.1
74-407	7/16"	78 mm	12/96	2.0/16.1
74-408	1/2"	78 mm	12/96	2.2/18.0
74-409	9/16"	78 mm	12/96	2.2/18.0
74-410	5/8"	78 mm	12/96	2.2/18.0
74-411	11/16"	78 mm	12/96	2.7/22.1
74-412	3/4"	78 mm	12/96	3.1/25.0
74-413	13/16"	78 mm	10/80	3.0/24.2
74-414	7/8"	78 mm	10/80	3.3/26.6
74-415	15/16"	78 mm	6/48	2.0/16.3
74-416	1"	78 mm	6/48	2.1/17.3
74-417	1-1/16"	78 mm	6/48	2.5/20.6
74-418	1-1/8"	78 mm	6/48	2.5/20.6
74-419	1-3/16"	78 mm	6/48	2.5/20.6
74-420	1-1/4"	78 mm	5/40	2.2/18.2



1/2" Impact Socket

■ **1/2" Drive Thin-Deep Impact Sockets (Metric)**



Item No.	Size (A)	Length		kgs
74-510	10 mm	78 mm	12/96	1.9/15.1
74-511	11 mm	78 mm	12/96	1.9/15.1
74-512	12 mm	78 mm	12/96	1.9/15.1
74-513	13 mm	78 mm	12/96	2.1/17.0
74-514	14 mm	78 mm	12/96	2.1/17.0
74-515	15 mm	78 mm	12/96	2.5/19.9
74-517	17 mm	78 mm	12/96	2.6/21.1
74-519	19 mm	78 mm	12/96	2.6/21.1
74-521	21 mm	78 mm	12/96	2.6/21.1
74-522	22 mm	78 mm	12/96	2.7/22.1
74-523	23 mm	78 mm	6/48	1.4/11.5
74-524	24 mm	78 mm	6/48	1.9/15.4

■ **1/2" Drive Hex Head Impact Sockets (Metric)**

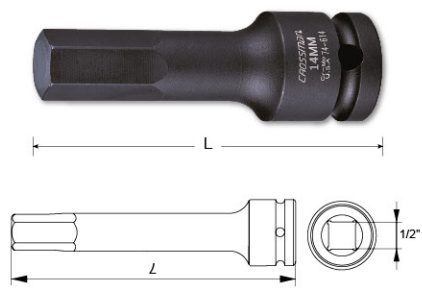

Item No.	Size	Length		kgs
74-604	4 mm	77 mm	10/200	0.9/18.4
74-605	5 mm	77 mm	10/200	0.9/19.4
74-606	6 mm	77 mm	10/200	1.0/19.8
74-607	7 mm	77 mm	10/200	1.0/20.4
74-608	8 mm	77 mm	10/200	1.1/21.8
74-609	9 mm	77 mm	10/200	1.1/22.4
74-610	10 mm	77 mm	10/200	1.3/27.4
74-611	11 mm	77 mm	10/200	1.4/28.0
74-612	12 mm	77 mm	10/200	1.4/28.6
74-613	13 mm	77 mm	10/200	1.4/28.6
74-614	14 mm	77 mm	10/200	1.4/28.6
74-615	15 mm	77 mm	10/200	1.4/29.0
74-616	16 mm	77 mm	10/200	1.4/29.0
74-617	17 mm	77 mm	10/100	1.5/14.9
74-618	18 mm	77 mm	10/100	1.7/16.9
74-619	19 mm	77 mm	10/100	2.2/21.9
74-620	20 mm	77 mm	10/100	2.3/22.9
74-621	21 mm	77 mm	10/100	2.4/23.9

■ **1/2" Drive TORX[®] Impact Sockets**

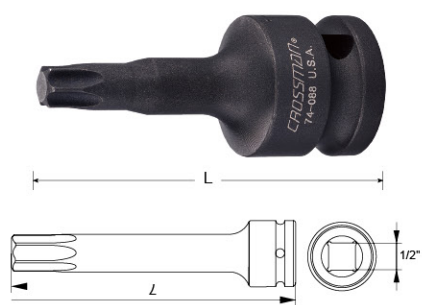

Item No.	Size	Length		kgs
74-081	T10	60 mm	10/200	1.0/19.8
74-082	T15	60 mm	10/200	1.0/19.8
74-083	T20	60 mm	10/200	1.0/19.8
74-084	T25	60 mm	10/200	1.0/19.8
74-085	T30	60 mm	10/200	1.0/19.8
74-087	T40	60 mm	10/200	1.0/19.8
74-088	T45	60 mm	10/200	1.1/21.8
74-089	T50	60 mm	10/200	1.1/21.8
74-090	T55	60 mm	10/100	1.2/12.5
74-091	T60	60 mm	10/100	1.2/13.5

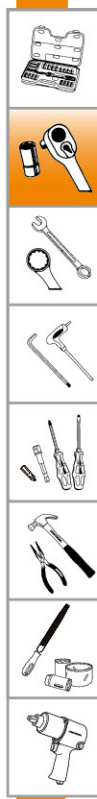

1/2" Impact Socket

1/2" Drive Hex Head Impact Sockets (SAE)

Item No.	Size	Length		 kgs
74-625	5/32"	77 mm	10/200	0.9/19.4
74-626	3/16"	77 mm	10/200	0.9/19.4
74-627	7/32"	77 mm	10/200	0.9/19.4
74-628	1/4"	77 mm	10/200	1.0/19.8
74-629	5/16"	77 mm	10/200	1.1/21.8
74-630	3/8"	77 mm	10/200	1.3/26.4
74-631	7/16"	77 mm	10/200	1.4/28.0
74-632	1/2"	77 mm	10/200	1.4/28.0
74-633	9/16"	77 mm	10/200	1.4/28.6
74-634	5/8"	77 mm	10/200	1.4/29.0
74-635	11/16"	77 mm	10/100	1.5/15.4
74-636	3/4"	77 mm	10/100	2.2/21.9
74-637	13/16"	77 mm	10/100	2.3/22.9

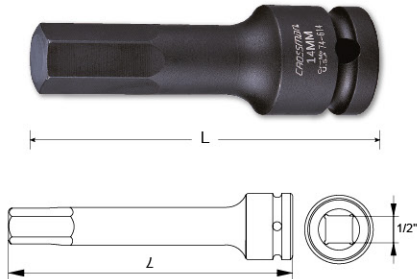

1/2" Socket Drive Impact Adapters

Item No.	Size		 kgs
73-006	1/2"F x 3/8"M	10/60	0.8/8.6
73-007	1/2"F x 3/4"M	20/120	3.4/20.7



1/2" Drive Impact Extensions

Item No.	Size (L)		 kgs
73-705	3"	10/100	2.3/23.7
73-706	5"	10/50	4.4/22.2
73-707	10"	10/60	4.6/27.9



1/2" Drive Impact Universal Joint

Item No.	Size		 kgs
73-907	63 mm	20/100	1.8/18.4



1/2" Impact Socket Set

1/2" Drive Impact Metric Socket Set - 11 Pcs.

Item No.		 kgs
74-001	1/20	1.1/21.7



- 11 Pcs. Sockets (Metric, 6-Point):
10, 11, 12, 13, 14, 15, 17, 19, 21, 24, 27 mm.

▲ Blow Mold Box



3/4" Impact Socket

3/4" Drive Impact Sockets (Metric)

Item No.	Size (A)	Length		 kgs
76-117	17 mm	50 mm	10/80	2.4/19.6
76-118	18 mm	50 mm	10/80	2.4/19.6
76-119	19 mm	50 mm	10/80	2.4/19.6
76-120	20 mm	50 mm	10/80	2.5/20.4
76-121	21 mm	50 mm	10/80	2.5/20.4
76-122	22 mm	50 mm	10/80	2.6/21.2
76-123	23 mm	50 mm	10/80	2.6/21.2
76-124	24 mm	50 mm	10/80	2.6/21.2
76-125	25 mm	50 mm	10/80	2.8/22.8
76-126	26 mm	50 mm	10/80	2.8/22.8
76-127	27 mm	50 mm	10/80	2.9/23.6
76-128	28 mm	50 mm	10/80	3.3/26.8
76-129	29 mm	53 mm	10/80	3.3/26.8
76-130	30 mm	53 mm	6/48	2.3/18.9
76-131	31 mm	53 mm	6/48	2.4/19.4
76-132	32 mm	53 mm	6/48	2.4/19.4
76-133	33 mm	55 mm	6/36	2.6/15.7
76-134	34 mm	55 mm	6/36	2.6/15.7
76-135	35 mm	55 mm	6/36	2.9/17.9
76-136	36 mm	55 mm	6/36	2.9/17.9
76-137	37 mm	57 mm	6/36	2.9/17.9
76-138	38 mm	57 mm	6/36	2.9/17.9
76-139	39 mm	57 mm	6/36	3.0/18.2
76-140	40 mm	57 mm	1/30	0.5/16.5
76-141	41 mm	57 mm	1/30	0.6/18.0
76-142	42 mm	57 mm	1/22	0.7/14.8
76-143	43 mm	62 mm	1/22	0.7/15.7
76-144	44 mm	62 mm	1/22	0.7/16.1
76-145	45 mm	62 mm	1/22	0.7/16.6
76-146	46 mm	62 mm	1/20	0.8/15.7
76-147	47 mm	62 mm	1/18	0.7/13.3
76-148	48 mm	62 mm	1/18	0.8/15.2
76-149	49 mm	62 mm	1/15	0.8/12.7
76-150	50 mm	62 mm	1/15	1.0/14.8
76-151	51 mm	62 mm	1/15	1.1/16.2
76-152	52 mm	62 mm	1/15	1.2/17.5
76-154	54 mm	62 mm	1/15	1.3/19.0
76-155	55 mm	62 mm	1/12	1.3/15.3
76-156	56 mm	62 mm	1/12	1.4/16.8
76-157	57 mm	62 mm	1/10	1.5/14.8
76-160	60 mm	65 mm	1/8	1.6/13.1
76-163	63 mm	65 mm	1/6	1.6/10.0
76-165	65 mm	65 mm	1/6	1.7/10.2
76-170	70 mm	70 mm	1/5	1.9/9.9

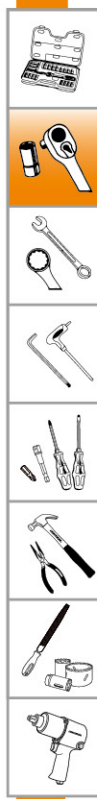

3/4" Impact Socket



3/4" Drive Impact Sockets (SAE)

Item No.	Size (A)	Length	 	 kgs
76-211	11/16"	51 mm	10/80	2.4/19.6
76-212	3/4"	51 mm	10/80	2.4/19.6
76-213	13/16"	51 mm	10/80	2.5/20.4
76-214	7/8"	51 mm	10/80	2.6/21.2
76-215	15/16"	51 mm	10/80	2.6/21.2
76-216	1"	53 mm	10/80	2.7/22.0
76-217	1-1/16"	53 mm	10/80	2.9/23.6
76-218	1-1/8"	53 mm	6/48	2.1/17.0
76-219	1-3/16"	53 mm	6/48	2.3/18.9
76-220	1-1/4"	57 mm	6/48	2.3/18.9
76-221	1-5/16"	57 mm	6/36	2.6/15.7
76-222	1-3/8"	57 mm	6/36	2.7/16.8
76-223	1-7/16"	57 mm	6/36	2.8/17.1
76-224	1-1/2"	57 mm	6/36	2.9/17.5
76-225	1-9/16"	58 mm	1/30	0.6/17.1
76-226	1-5/8"	58 mm	1/30	0.6/18.0
76-227	1-11/16"	62 mm	1/22	0.7/15.7
76-228	1-3/4"	62 mm	1/22	0.8/16.8
76-229	1-13/16"	62 mm	1/20	0.8/15.7
76-230	1-7/8"	68 mm	1/18	0.8/14.5
76-231	1-15/16"	68 mm	1/15	0.8/12.1
76-232	2"	68 mm	1/15	0.9/13.5
76-233	2-1/16"	71 mm	1/15	0.9/14.1
76-234	2-1/8"	71 mm	1/15	1.3/19.0
76-235	2-3/16"	71 mm	1/12	1.3/15.3
76-236	2-1/4"	73 mm	1/10	1.5/14.8
76-237	2-5/16"	73 mm	1/8	1.5/12.3
76-238	2-3/8"	73 mm	1/8	1.6/12.7
76-239	2-1/2"	75 mm	1/6	1.6/10.0
76-240	2-9/16"	80 mm	1/6	1.7/10.6
76-241	2-5/8"	80 mm	1/5	1.8/9.4
76-242	2-3/4"	85 mm	1/5	1.9/9.9



3/4" Impact Socket

3/4" Drive Deep Impact Sockets (Metric)

Item No.	Size (A)	Length		 kgs
76-317	17 mm	90 mm	6/48	2.4/19.9
76-318	18 mm	90 mm	6/48	2.4/19.9
76-319	19 mm	90 mm	6/48	2.4/19.9
76-320	20 mm	90 mm	6/48	2.4/19.9
76-321	21 mm	90 mm	6/48	2.5/20.4
76-322	22 mm	90 mm	6/48	2.7/21.8
76-323	23 mm	90 mm	6/48	2.7/21.8
76-324	24 mm	90 mm	6/48	2.7/22.3
76-325	25 mm	90 mm	6/48	2.9/23.3
76-326	26 mm	90 mm	5/40	2.4/19.6
76-327	27 mm	90 mm	5/40	2.6/21.2
76-328	28 mm	90 mm	5/40	2.8/23.2
76-329	29 mm	90 mm	5/40	2.9/23.6
76-330	30 mm	90 mm	5/40	3.2/26.0
76-332	32 mm	90 mm	5/40	3.2/26.4
76-333	33 mm	90 mm	4/32	2.8/22.6
76-334	34 mm	90 mm	4/32	2.8/22.6
76-335	35 mm	90 mm	4/32	3.2/25.8
76-336	36 mm	90 mm	4/32	3.1/25.2
76-337	37 mm	90 mm	4/24	3.3/20.1
76-338	38 mm	90 mm	4/24	3.4/20.9
76-340	40 mm	90 mm	4/24	3.6/22.1
76-341	41 mm	90 mm	4/24	3.6/22.1
76-342	42 mm	90 mm	3/18	3.2/19.8
76-343	43 mm	90 mm	3/18	3.2/19.8
76-344	44 mm	90 mm	3/18	3.4/20.6
76-345	45 mm	90 mm	3/18	3.4/20.6
76-346	46 mm	90 mm	3/18	3.5/21.6
76-349	49 mm	90 mm	3/18	3.8/22.9
76-350	50 mm	90 mm	3/18	4.1/24.7



3/4" Drive Deep Impact Sockets (SAE)

Item No.	Size (A)	Length		 kgs
76-411	11/16"	90 mm	6/48	2.4/19.9
76-412	3/4"	90 mm	6/48	2.4/19.9
76-413	13/16"	90 mm	6/48	2.5/20.4
76-414	7/8"	90 mm	6/48	2.7/22.3
76-415	15/16"	90 mm	6/48	2.7/22.3
76-416	1"	90 mm	6/48	2.8/22.8
76-417	1-1/16"	90 mm	5/40	2.6/21.6
76-418	1-1/8"	90 mm	5/40	2.9/24.0
76-419	1-3/16"	90 mm	5/40	3.1/25.6
76-420	1-1/4"	90 mm	4/32	2.6/21.3
76-421	1-5/16"	90 mm	4/32	2.7/22.3
76-422	1-3/8"	90 mm	4/32	3.2/25.8
76-423	1-7/16"	90 mm	4/24	3.2/19.4
76-424	1-1/2"	90 mm	4/24	3.4/20.9
76-425	1-9/16"	90 mm	4/24	3.5/21.6
76-426	1-5/8"	90 mm	4/24	3.6/21.8
76-427	1-11/16"	90 mm	3/18	3.2/19.8
76-428	1-3/4"	90 mm	3/18	3.4/20.6
76-429	1-13/16"	90 mm	3/18	3.5/21.6
76-430	1-7/8"	90 mm	3/18	3.7/22.5
76-431	1-15/16"	90 mm	3/18	3.8/23.4
76-432	2"	90 mm	3/18	4.0/24.5

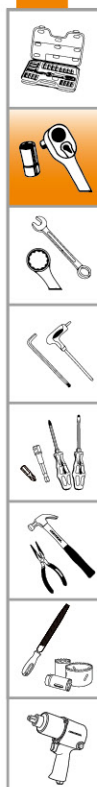

3/4" Impact Socket

3/4" Drive Hex Head Impact Sockets (Metric)

Item No.	Size	Length		 kgs
76-619	19 mm	90 mm	6/36	3.7/22.5
76-620	21 mm	90 mm	6/36	3.8/22.9
76-621	22 mm	90 mm	6/36	3.8/23.3
76-622	24 mm	90 mm	5/30	3.5/21.6
76-623	27 mm	90 mm	5/30	3.7/22.5
76-624	30 mm	90 mm	5/30	4.2/25.8
76-625	32 mm	90 mm	5/30	4.3/26.4

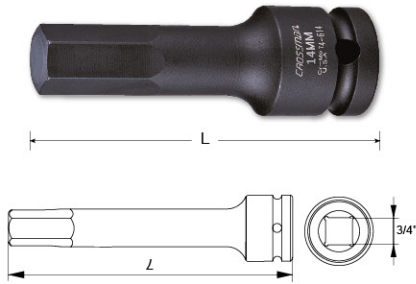

3/4" Drive Hex Head Impact Sockets (SAE)

Item No.	Size	Length		 kgs
76-612	3/4"	90 mm	6/36	3.7/22.5
76-613	13/16"	90 mm	6/36	3.8/22.9
76-614	7/8"	90 mm	6/36	3.8/23.3
76-615	15/16"	90 mm	5/30	3.4/20.7
76-616	1"	90 mm	5/30	3.5/21.3
76-617	1-1/16"	90 mm	5/30	3.7/22.5
76-618	1-1/8"	90 mm	5/30	3.9/23.6
76-629	1-3/16"	90 mm	5/30	4.2/25.8
76-630	1-1/4"	90 mm	5/30	4.3/26.4

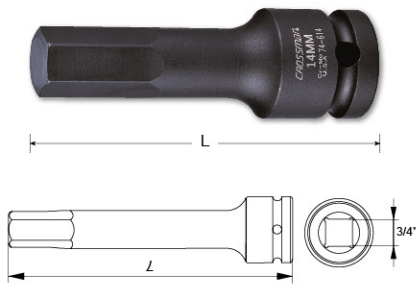



3/4" Socket Drive Impact Adapters

Item No.	Size		 kgs
73-008	3/4"F x 1/2"M	8/48	2.7/16.5
73-009	3/4"F x 1"M	5/30	2.3/14.4





3/4" Drive Impact Extensions

Item No.	Size (L)		 kgs
73-709	4"	6/36	3.4/21.0
73-710	6"	6/30	4.7/24.0
73-711	7"	6/24	5.3/21.8
73-712	8"	6/24	5.9/24.2
73-713	10"	3/18	3.5/21.5





3/4" Drive Impact Universal Joint

Item No.	Size		 kgs
73-908	90 mm	4/24	2.3/13.9



1" Impact Socket

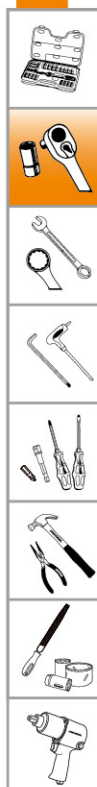

■ 1" Drive Impact Sockets (Metric)

Item No.	Size (A)	Length		 kgs
78-117	17 mm	57 mm	6/48	3.0/24.7
78-119	19 mm	57 mm	6/48	3.1/25.2
78-121	21 mm	57 mm	6/48	3.1/25.2
78-122	22 mm	57 mm	6/48	3.2/25.7
78-123	23 mm	57 mm	6/36	3.2/19.3
78-124	24 mm	57 mm	6/36	3.2/19.3
78-125	25 mm	57 mm	6/36	3.2/19.3
78-126	26 mm	57 mm	6/36	3.2/19.7
78-127	27 mm	57 mm	6/36	3.2/19.7
78-128	28 mm	57 mm	6/36	3.3/20.0
78-129	29 mm	62 mm	6/36	3.3/20.0
78-130	30 mm	62 mm	6/36	3.3/20.0
78-131	31 mm	62 mm	6/36	3.5/21.1
78-132	32 mm	62 mm	6/36	3.6/22.2
78-133	33 mm	62 mm	6/36	3.8/23.3
78-134	34 mm	62 mm	6/36	3.9/24.0
78-135	35 mm	62 mm	6/36	4.0/24.3
78-136	36 mm	62 mm	5/30	3.4/21.0
78-137	37 mm	62 mm	5/30	3.4/21.0
78-138	38 mm	66 mm	5/30	3.5/21.3
78-139	39 mm	66 mm	5/30	3.9/24.0
78-140	40 mm	66 mm	5/30	4.4/27.0
78-141	41 mm	66 mm	5/30	4.7/28.5
78-142	42 mm	68 mm	1/24	1.0/23.8
78-143	43 mm	70 mm	1/24	1.0/24.3
78-144	44 mm	70 mm	1/20	1.0/20.3
78-146	46 mm	70 mm	1/15	1.0/15.3
78-147	47 mm	70 mm	1/15	1.0/15.3
78-148	48 mm	70 mm	1/15	1.1/16.0
78-149	49 mm	70 mm	1/15	1.1/16.2
78-150	50 mm	70 mm	1/13	1.1/14.2
78-151	51 mm	76 mm	1/13	1.1/14.2
78-152	52 mm	80 mm	1/13	1.1/14.6
78-154	54 mm	80 mm	1/13	1.3/16.5
78-155	55 mm	84 mm	1/12	1.4/17.6
78-156	56 mm	84 mm	1/12	1.4/17.6
78-157	57 mm	84 mm	1/12	1.6/19.7
78-158	58 mm	84 mm	1/12	1.6/19.7
78-160	60 mm	88 mm	1/12	1.7/21.1
78-162	62 mm	88 mm	1/8	1.8/14.7
78-163	63 mm	88 mm	1/8	1.9/15.5
78-165	65 mm	92 mm	1/8	1.9/15.5
78-167	67 mm	92 mm	1/8	2.1/17.1
78-168	68 mm	96 mm	1/8	2.1/17.3
78-170	70 mm	96 mm	1/6	2.2/13.4
78-173	73 mm	96 mm	1/6	2.8/17.1
78-175	75 mm	102 mm	1/6	3.2/19.5
78-176	76 mm	102 mm	1/6	3.5/21.2
78-180	80 mm	102 mm	1/5	3.7/18.5
78-185	85 mm	106 mm	1/5	4.1/20.8
78-190	90 mm	108 mm	1/4	5.2/21.1
78-195	95 mm	108 mm	1/4	5.3/21.3



1" Impact Socket



1" Drive Impact Sockets (SAE)

Item No.	Size (A)	Length	 	 kgs
78-211	11/16"	58 mm	6/48	3.0/24.2
78-212	3/4"	58 mm	6/48	3.1/25.2
78-213	13/16"	58 mm	6/48	3.2/25.7
78-214	7/8"	58 mm	6/48	3.2/25.7
78-215	15/16"	58 mm	6/36	3.2/19.3
78-216	1"	60 mm	6/36	3.2/19.7
78-217	1-1/16"	60 mm	6/36	3.2/19.7
78-218	1-1/8"	62 mm	6/36	3.3/20.0
78-219	1-3/16"	62 mm	6/36	3.4/20.7
78-220	1-1/4"	63 mm	6/36	3.8/22.9
78-221	1-5/16"	63 mm	6/36	3.8/23.3
78-222	1-3/8"	66 mm	6/36	3.9/23.6
78-223	1-7/16"	66 mm	5/30	3.3/20.1
78-224	1-1/2"	66 mm	5/30	3.4/21.0
78-225	1-9/16"	66 mm	5/30	4.4/27.0
78-226	1-5/8"	68 mm	5/30	4.7/28.5
78-227	1-11/16"	70 mm	1/24	0.9/22.4
78-228	1-3/4"	70 mm	1/20	1.0/20.3
78-229	1-13/16"	72 mm	1/15	1.0/15.3
78-230	1-7/8"	72 mm	1/15	1.1/16.5
78-231	1-15/16"	76 mm	1/15	1.1/16.5
78-232	2"	76 mm	1/13	1.1/14.6
78-233	2-1/16"	80 mm	1/13	1.2/15.9
78-234	2-1/8"	80 mm	1/13	1.3/16.5
78-235	2-3/16"	84 mm	1/12	1.5/17.7
78-236	2-1/4"	84 mm	1/12	1.5/18.5
78-237	2-5/16"	84 mm	1/12	1.5/18.5
78-238	2-3/8"	88 mm	1/12	1.7/20.9
78-239	2-7/16"	88 mm	1/8	1.9/15.4
78-240	2-1/2"	88 mm	1/8	1.9/15.5
78-241	2-9/16"	92 mm	1/8	1.9/15.5
78-242	2-5/8"	92 mm	1/8	2.0/16.3
78-243	2-11/16"	96 mm	1/8	2.2/17.9
78-244	2-3/4"	96 mm	1/6	2.3/13.8
78-245	2-13/16"	96 mm	1/6	2.4/14.6
78-246	2-7/8"	96 mm	1/6	2.4/14.7
78-247	2-15/16"	100 mm	1/6	3.2/19.4
78-248	3"	100 mm	1/6	3.5/21.0
78-249	3-1/16"	100 mm	1/6	3.5/21.5
78-250	3-1/8"	102 mm	1/5	3.6/18.4
78-251	3-1/4"	104 mm	1/5	3.8/19.3
78-252	3-3/8"	106 mm	1/4	4.1/16.5
78-253	3-1/2"	108 mm	1/4	5.2/21.0
78-254	3-5/8"	110 mm	1/4	5.2/21.1
78-255	3-3/4"	110 mm	1/4	5.3/21.3



1" Impact Socket

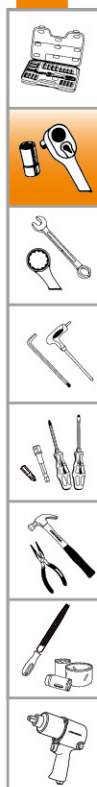
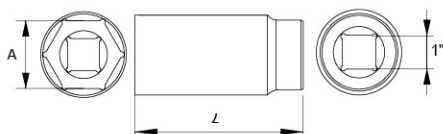

1" Drive Deep Impact Sockets (Metric)

Item No.	Size (A)	Length		 kgs
78-319	19 mm	108 mm	1/30	0.7/21.3
78-321	21 mm	108 mm	1/30	0.7/21.6
78-322	22 mm	108 mm	1/30	0.7/21.6
78-323	23 mm	108 mm	1/30	0.7/21.6
78-324	24 mm	108 mm	1/30	0.7/21.9
78-325	25 mm	108 mm	1/30	0.7/21.9
78-326	26 mm	108 mm	1/30	0.8/22.8
78-327	27 mm	108 mm	1/30	0.8/24.3
78-328	28 mm	108 mm	1/28	0.8/22.7
78-329	29 mm	108 mm	1/28	0.8/22.7
78-330	30 mm	108 mm	1/25	0.8/20.3
78-331	31 mm	108 mm	1/25	0.9/21.7
78-332	32 mm	108 mm	1/22	0.9/20.3
78-333	33 mm	108 mm	1/22	0.9/20.3
78-334	34 mm	108 mm	1/20	1.0/19.3
78-335	35 mm	108 mm	1/20	1.0/19.3
78-336	36 mm	108 mm	1/18	1.0/17.4
78-337	37 mm	108 mm	1/18	1.0/17.6
78-338	38 mm	108 mm	1/15	1.0/15.1
78-339	39 mm	108 mm	1/15	1.1/16.2
78-341	41 mm	108 mm	1/15	1.2/18.3
78-342	42 mm	108 mm	1/15	1.2/18.3
78-343	43 mm	108 mm	1/13	1.2/15.9
78-346	46 mm	108 mm	1/13	1.4/18.0
78-347	47 mm	108 mm	1/13	1.4/18.5
78-348	48 mm	108 mm	1/13	1.5/19.1
78-349	49 mm	108 mm	1/13	1.5/19.9
78-350	50 mm	108 mm	1/12	1.6/19.1
78-352	52 mm	108 mm	1/12	1.6/19.5
78-354	54 mm	108 mm	1/12	1.8/21.3
78-355	55 mm	108 mm	1/10	2.0/19.8
78-356	56 mm	108 mm	1/10	2.1/21.0
78-357	57 mm	108 mm	1/10	2.2/22.3
78-358	58 mm	108 mm	1/10	2.3/22.8
78-360	60 mm	108 mm	1/8	2.4/19.1
78-363	63 mm	108 mm	1/6	2.6/15.6
78-365	65 mm	108 mm	1/6	3.0/18.0
78-370	70 mm	108 mm	1/5	3.3/16.8
78-375	75 mm	108 mm	1/4	4.6/18.5
78-380	80 mm	108 mm	1/4	4.9/19.7
78-385	85 mm	135 mm	1/2	5.3/10.8
78-390	90 mm	135 mm	1/2	5.8/11.8



1" Impact Socket

1" Drive Deep Impact Sockets (SAE)

Item No.	Size (A)	Length		 kgs
78-412	3/4"	108 mm	1/30	0.7/21.3
78-413	13/16"	108 mm	1/30	0.7/21.3
78-414	7/8"	108 mm	1/30	0.7/21.6
78-415	15/16"	108 mm	1/30	0.7/21.9
78-416	1"	108 mm	1/30	0.8/23.1
78-417	1-1/16"	108 mm	1/30	0.8/24.3
78-418	1-1/8"	108 mm	1/28	0.8/22.7
78-419	1-3/16"	108 mm	1/25	0.8/20.8
78-420	1-1/4"	108 mm	1/22	0.9/20.3
78-421	1-5/16"	108 mm	1/22	0.9/20.3
78-422	1-3/8"	108 mm	1/20	0.9/18.5
78-423	1-7/16"	108 mm	1/18	1.0/17.4
78-424	1-1/2"	108 mm	1/15	1.0/15.3
78-425	1-9/16"	108 mm	1/15	1.2/18.3
78-426	1-5/8"	108 mm	1/15	1.2/18.3
78-427	1-11/16"	108 mm	1/13	1.2/15.9
78-428	1-3/4"	108 mm	1/13	1.4/17.8
78-429	1-13/16"	108 mm	1/13	1.4/17.8
78-430	1-7/8"	108 mm	1/13	1.5/19.8
78-431	1-15/16"	108 mm	1/13	1.6/20.6
78-432	2"	108 mm	1/12	1.6/19.0
78-433	2-1/16"	108 mm	1/12	1.6/19.5
78-434	2-1/8"	108 mm	1/12	1.8/21.3
78-435	2-3/16"	108 mm	1/10	2.0/20.3
78-436	2-1/4"	108 mm	1/10	2.2/22.3
78-437	2-5/16"	108 mm	1/8	2.3/18.4
78-438	2-3/8"	108 mm	1/8	2.4/19.1
78-440	2-1/2"	120 mm	1/6	2.6/15.8
78-441	2-9/16"	120 mm	1/6	3.0/18.3
78-442	2-5/8"	120 mm	1/6	3.2/19.6
78-443	2-3/4"	125 mm	1/5	3.3/16.7
78-444	2-7/8"	125 mm	1/4	4.6/18.5
78-445	2-15/16"	125 mm	1/4	4.6/18.5
78-446	3"	125 mm	1/4	4.6/18.5
78-447	3-1/16"	125 mm	1/4	4.7/19.1
78-448	3-1/8"	125 mm	1/4	4.9/19.7

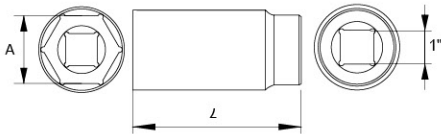



1" Impact Socket

1" Drive Hex Head Impact Sockets (Metric)

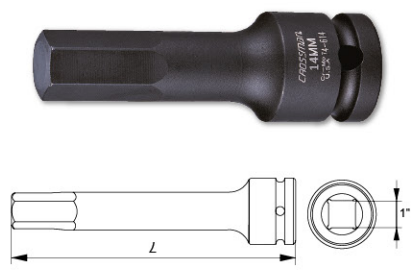

Item No.	Size	Length		kgs
78-619	19 mm	100 mm	4/24	3.3/20.4
78-620	21 mm	100 mm	4/24	3.4/20.9
78-621	22 mm	100 mm	4/24	3.5/21.1
78-622	24 mm	100 mm	4/24	3.7/22.3
78-623	27 mm	100 mm	4/24	3.8/23.3
78-624	30 mm	100 mm	4/24	4.3/26.1
78-625	32 mm	100 mm	4/20	5.1/26.1

1" Drive Hex Head Impact Sockets (SAE)

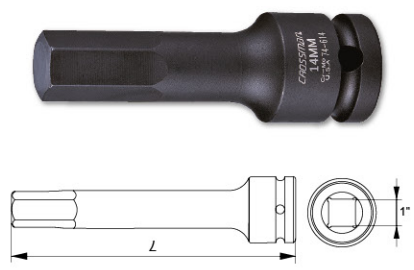

Item No.	Size	Length		kgs
78-612	3/4"	100 mm	4/24	3.3/20.4
78-613	13/16"	100 mm	4/24	3.4/20.9
78-614	7/8"	100 mm	4/24	3.6/21.8
78-615	15/16"	100 mm	4/24	3.7/22.3
78-616	1"	100 mm	4/24	3.7/22.8
78-617	1-1/16"	100 mm	4/24	3.8/23.3
78-618	1-1/8"	100 mm	4/24	4.0/24.2
78-629	1-3/16"	100 mm	4/24	4.3/26.1
78-630	1-1/4"	100 mm	4/20	5.1/26.1

1" Socket Drive Impact Adapter



Item No.	Size		kgs
73-010	1"F x 3/4"M	6/36	3.5/21.5

1" Drive Impact Extensions



Item No.	Size		kgs
73-714	4"	3/24	3.0/24.9
73-715	6"	3/18	4.0/24.9
73-716	7"	3/18	4.5/27.9
73-717	8"	3/15	5.0/25.9
73-718	10"	3/12	6.1/25.1
73-719	12"	3/12	7.1/28.9
73-720	13"	3/9	7.5/23.2

1" Drive Impact Universal Joint



Item No.	Size		kgs
73-909	110 mm	3/18	3.2/19.3



Wrenches



■ Combination Wrenches - 12 Point (Metric)

Item No.	Size	Length		kgs
96-851	6 mm	128 mm	25/500	0.6/13.2
96-852	7 mm	138 mm	25/500	0.8/16.5
96-853	8 mm	148 mm	25/500	1.0/19.9
96-854	9 mm	154 mm	20/400	0.9/18.8
96-855	10 mm	162 mm	20/400	1.1/22.4
96-856	11 mm	167 mm	20/200	1.3/13.4
96-857	12 mm	174 mm	20/200	1.7/16.9
96-858	13 mm	178 mm	20/200	1.8/18.1
96-859	14 mm	190 mm	20/200	2.2/22.5
96-860	15 mm	205 mm	15/150	2.1/21.9
96-861	16 mm	205 mm	15/150	2.2/22.7
96-862	17 mm	225 mm	15/150	2.4/24.4
96-863	18 mm	248 mm	20/80	4.2/17.4
96-864	19 mm	248 mm	20/80	4.1/16.8
96-865	20 mm	270 mm	20/80	4.9/20.3
96-866	21 mm	270 mm	20/80	5.3/21.8
96-867	22 mm	292 mm	15/60	4.6/19.1
96-868	23 mm	314 mm	6/36	2.3/14.4
96-869	24 mm	314 mm	6/36	2.3/14.4
96-625	25 mm	336 mm	6/36	2.9/17.9
96-626	26 mm	336 mm	6/36	2.8/17.6
96-627	27 mm	359 mm	6/36	3.5/21.5
96-628	28 mm	390 mm	6/36	4.3/26.2
96-629	29 mm	390 mm	6/36	4.0/24.6
96-630	30 mm	390 mm	6/36	4.0/24.2
96-631	31 mm	425 mm	6/24	5.7/23.4
96-871	32 mm	425 mm	6/24	5.7/22.9

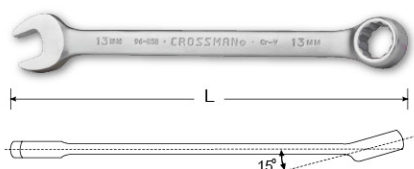

■ Raise Panel Wrenches - 12 Point (Metric)

Item No.	Size	Length		kgs
96-933	33 mm	435 mm	1/25	1.2/29.4
96-934	34 mm	435 mm	1/25	1.2/29.5
96-935	35 mm	455 mm	1/15	1.3/20.1
96-936	36 mm	490 mm	1/15	1.6/24.4
96-937	37 mm	490 mm	1/15	1.6/24.8
96-938	38 mm	490 mm	1/15	1.6/24.4
96-941	41 mm	545 mm	1/10	2.1/21.3
96-942	42 mm	545 mm	1/10	2.1/21.2
96-943	43 mm	545 mm	1/10	2.0/20.7
96-944	44 mm	545 mm	1/10	2.0/20.0
96-945	45 mm	545 mm	1/10	2.0/20.3
96-946	46 mm	545 mm	1/10	2.0/20.5
96-948	48 mm	610 mm	1/10	2.7/27.3
96-950	50 mm	610 mm	1/10	2.8/28.8
96-960	60 mm	630 mm	1/6	4.1/24.8

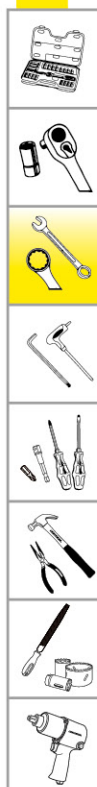
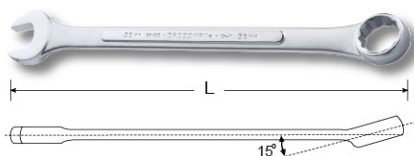



Wrenches



■ Combination Wrenches - 12 Point (SAE)

Item No.	Size	Length		kgs
96-831	1/4"	128 mm	25/500	0.6/13.2
96-832	5/16"	148 mm	25/500	1.0/20.2
96-833	3/8"	154 mm	20/400	0.9/18.8
96-834	7/16"	167 mm	20/400	1.1/21.7
96-835	1/2"	178 mm	20/200	1.8/18.7
96-836	9/16"	190 mm	20/200	2.2/22.5
96-837	5/8"	205 mm	15/150	2.0/20.0
96-838	11/16"	225 mm	15/150	2.3/23.9
96-839	3/4"	248 mm	20/80	4.0/16.4
96-840	13/16"	270 mm	20/80	5.2/21.2
96-841	7/8"	292 mm	15/60	4.8/20.0
96-842	15/16"	314 mm	10/60	3.9/24.0
96-843	1"	336 mm	6/36	2.8/17.3
96-844	1-1/16"	359 mm	6/36	3.3/20.5
96-845	1-1/8"	390 mm	6/36	5.8/23.7
96-846	1-1/4"	425 mm	6/24	5.7/23.0

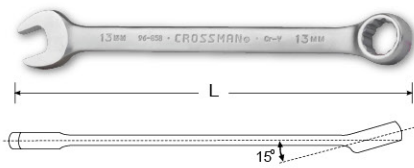

■ Raise Panel Wrenches - 12 Point (SAE)

Item No.	Size	Length		kgs
96-901	1-5/16"	435 mm	1/24	1.2/28.1
96-902	1-3/8"	455 mm	1/15	1.3/20.4
96-903	1-7/16"	497 mm	1/15	1.6/24.5
96-904	1-1/2"	497 mm	1/15	1.5/23.5
96-905	1-5/8"	545 mm	1/10	2.1/21.0
96-906	1-3/4"	545 mm	1/10	2.1/21.2
96-909	2"	610 mm	1/10	2.6/26.8

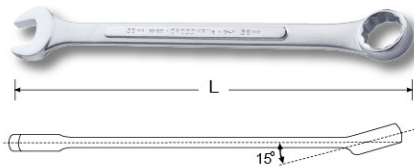





Wrenches



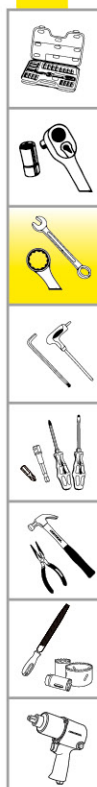
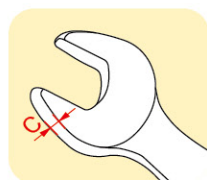
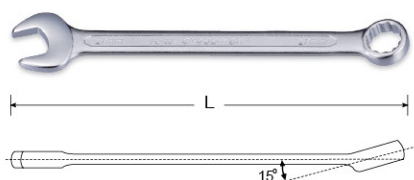

■ Thin Combination Wrenches - 12 Point (Metric)

Item No.	Size	Length	C	 	 kgs
92-106	6 mm	102 mm	3.6 mm	25/500	0.5/9.7
92-107	7 mm	112 mm	4.0 mm	25/500	0.6/11.7
92-108	8 mm	122 mm	4.5 mm	25/500	0.7/14.2
92-109	9 mm	132 mm	4.7 mm	25/500	0.9/18.9
92-110	10 mm	140 mm	4.9 mm	25/500	1.0/21.2
92-111	11 mm	150 mm	5.0 mm	20/400	1.0/21.2
92-112	12 mm	160 mm	5.4 mm	20/200	1.3/13.1
92-113	13 mm	170 mm	5.9 mm	20/200	1.6/16.1
92-114	14 mm	180 mm	6.2 mm	20/200	1.9/19.5
92-115	15 mm	190 mm	6.5 mm	20/200	2.0/20.1
92-116	16 mm	200 mm	6.6 mm	15/150	1.7/12.9
92-117	17 mm	210 mm	6.7 mm	15/90	2.1/12.9
92-118	18 mm	220 mm	7.1 mm	15/90	2.3/14.4
92-119	19 mm	230 mm	7.4 mm	15/90	2.5/15.8
92-120	20 mm	240 mm	7.6 mm	15/90	2.8/17.6
92-121	21 mm	250 mm	7.8 mm	20/80	4.3/17.5
92-122	22 mm	260 mm	8.0 mm	20/80	4.8/19.6
92-123	23 mm	270 mm	8.4 mm	20/80	5.1/21.2
92-124	24 mm	280 mm	8.5 mm	15/60	4.2/17.5
92-125	25 mm	290 mm	8.8 mm	15/60	4.6/19.1
92-126	26 mm	300 mm	9.0 mm	15/60	4.8/19.9
92-127	27 mm	310 mm	9.2 mm	10/60	3.7/22.9
92-128	28 mm	320 mm	9.3 mm	10/60	4.0/24.7
92-129	29 mm	330 mm	9.5 mm	6/36	2.8/17.3
92-130	30 mm	340 mm	9.9 mm	6/36	3.1/18.9
92-132	32 mm	360 mm	10.3 mm	6/36	3.3/20.2
92-133	33 mm	380 mm	11.6 mm	6/24	3.9/15.9
92-134	34 mm	380 mm	11.6 mm	6/24	4.1/16.8
92-135	35 mm	410 mm	13.2 mm	6/24	5.2/21.4
92-136	36 mm	410 mm	13.2 mm	6/24	5.4/22.2
92-138	38 mm	440 mm	14.4 mm	1/15	1.1/17.3
92-141	41 mm	460 mm	14.5 mm	1/12	1.4/17.5
92-142	42 mm	460 mm	14.5 mm	1/12	1.4/17.3
92-143	43 mm	460 mm	14.5 mm	1/12	1.4/16.8
92-144	44 mm	500 mm	15.0 mm	1/12	1.9/23.1
92-145	45 mm	500 mm	15.0 mm	1/12	1.9/23.1
92-146	46 mm	500 mm	15.0 mm	1/12	1.9/23.1
92-148	48 mm	540 mm	16.9 mm	1/10	2.3/23.0
92-150	50 mm	540 mm	16.9 mm	1/10	2.2/22.2





Wrenches

■ Stubby Combination Wrenches - 12 Point (Metric)

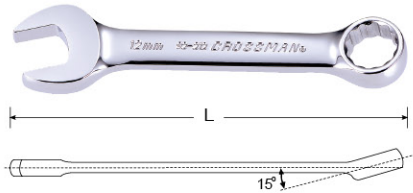
Item No.	Size	Length		 kgs
92-206	6 mm	77 mm	25/500	0.5/10.0
92-207	7 mm	80 mm	25/500	0.6/12.5
92-208	8 mm	85 mm	25/500	0.6/13.0
92-209	9 mm	90 mm	20/400	0.7/15.0
92-210	10 mm	95 mm	20/400	1.2/24.0
92-211	11 mm	100 mm	20/400	1.2/24.0
92-212	12 mm	104 mm	15/300	1.1/23.0
92-213	13 mm	109 mm	15/300	1.2/25.0
92-214	14 mm	114 mm	15/300	1.3/26.4
92-215	15 mm	120 mm	10/200	0.9/18.7
92-216	16 mm	124 mm	10/200	1.0/20.9
92-217	17 mm	130 mm	10/160	1.3/21.0
92-218	18 mm	134 mm	8/128	1.1/18.6
92-219	19 mm	140 mm	5/80	0.9/15.4
92-222	22 mm	165 mm	10/120	2.4/20.5



■ Stubby Combination Wrenches - 12 Point (SAE)

Item No.	Size	Length		 kgs
92-231	1/4"	77 mm	25/500	0.5/10.0
92-232	5/16"	85 mm	25/500	0.6/13.0
92-233	3/8"	95 mm	20/400	1.2/24.0
92-234	7/16"	100 mm	20/400	1.2/24.0
92-235	1/2"	109 mm	15/300	0.9/19.9
92-236	9/16"	114 mm	15/300	1.3/26.4
92-237	5/8"	124 mm	10/200	1.0/20.9
92-238	11/16"	130 mm	10/200	1.3/27.0
92-239	3/4"	140 mm	5/100	0.9/18.6

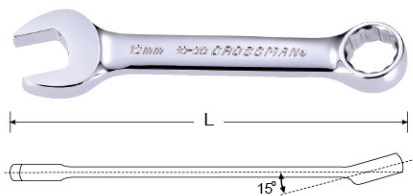



Wrenches



■ Box End Wrenches - 12 Point (Metric)

Item No.	Size	Length		 kgs
96-115	6 mm x 7 mm	161 mm	12/240	0.6/11.9
96-127	8 mm x 9 mm	178 mm	12/120	0.7/7.4
96-128	8 mm x 10 mm	178 mm	12/120	0.7/7.0
96-130	10 mm x 12 mm	195 mm	12/120	0.9/9.2
96-132	11 mm x 13 mm	214 mm	12/120	1.2/12.4
96-134	12 mm x 14 mm	230 mm	12/120	1.5/15.4
96-137	14 mm x 17 mm	255 mm	12/120	2.2/23.0
96-138	16 mm x 17 mm	255 mm	12/120	2.5/25.5
96-140	17 mm x 19 mm	295 mm	12/72	3.2/19.9
96-143	19 mm x 21 mm	320 mm	12/48	4.5/18.5
96-145	20 mm x 22 mm	320 mm	12/48	4.6/18.9
96-146	21 mm x 23 mm	320 mm	12/48	4.5/18.6
96-148	22 mm x 24 mm	350 mm	6/36	2.3/14.3
96-149	23 mm x 26 mm	350 mm	6/36	3.2/19.8
96-150	24 mm x 27 mm	350 mm	6/36	3.2/19.8

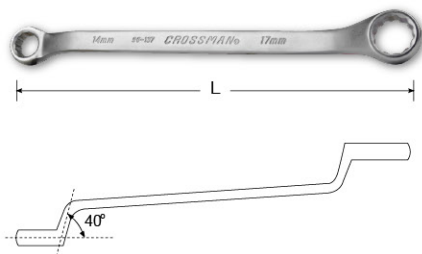

■ Box End Wrenches - 12 Point (SAE)

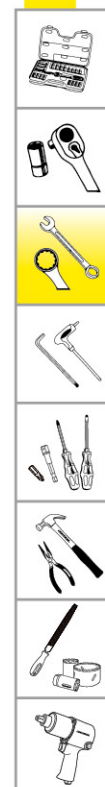
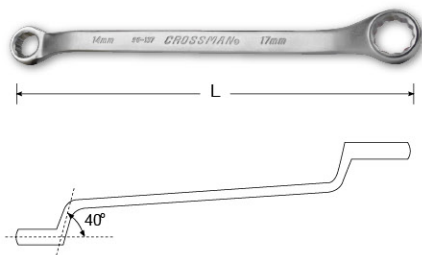

Item No.	Size	Length		 kgs
96-874	1/4" x 5/16"	161 mm	12/240	0.6/11.9
96-876	3/8" x 7/16"	195 mm	12/120	0.9/9.2
96-878	1/2" x 9/16"	230 mm	12/120	1.5/15.8
96-880	5/8" x 11/16"	255 mm	12/72	2.4/15.2
96-881	5/8" x 3/4"	295 mm	12/72	3.2/19.9
96-882	3/4" x 7/8"	310 mm	12/48	4.5/18.5
96-884	13/16" x 7/8"	320 mm	12/48	4.7/19.3
96-886	15/16" x 1"	350 mm	6/36	3.1/19.3



Wrenches

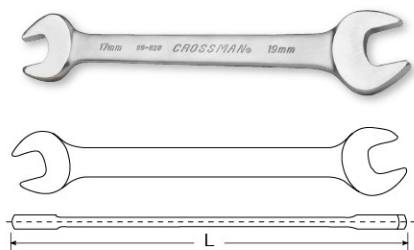

■ Open End Wrenches (Metric)

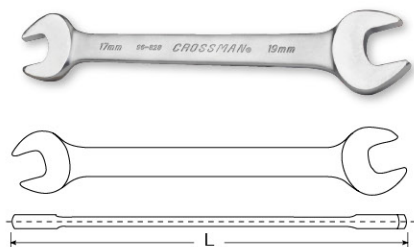

Item No.	Size	Length		 kgs
96-817	6 mm x 7 mm	123 mm	12/240	0.3/6.6
96-818	8 mm x 9 mm	140 mm	12/240	0.5/9.7
96-820	8 mm x 10 mm	140 mm	12/240	0.5/11.1
96-821	10 mm x 12 mm	156 mm	12/240	0.8/16.7
96-822	11 mm x 13 mm	172 mm	12/240	0.8/16.8
96-823	12 mm x 14 mm	180 mm	12/240	1.2/24.6
96-824	14 mm x 17 mm	190 mm	12/120	1.3/13.4
96-828	17 mm x 19 mm	221 mm	12/120	2.0/21.0
96-636	19 mm x 21 mm	237 mm	12/72	2.7/16.7
96-641	21 mm x 23 mm	247 mm	12/72	3.0/18.6
96-077	22 mm x 24 mm	247 mm	12/72	3.0/18.7
96-642	25 mm x 28 mm	278 mm	12/72	3.2/20.0
96-643	30 mm x 32 mm	278 mm	12/72	3.2/20.0

■ Open End Wrenches (SAE)



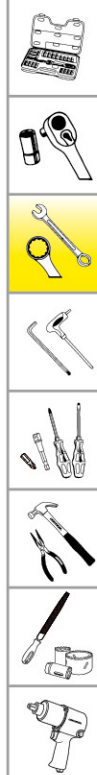

Item No.	Size	Length		 kgs
96-800	1/4" x 5/16"	123 mm	12/240	0.4/7.6
96-705	5/16" x 3/8"	140 mm	12/240	0.5/11.1
96-801	3/8" x 7/16"	156 mm	12/240	0.8/16.7
96-706	7/16" x 1/2"	172 mm	12/240	1.0/20.1
96-803	1/2" x 9/16"	180 mm	12/240	1.1/22.6
96-806	9/16" x 5/8"	190 mm	12/120	1.2/12.5
96-707	5/8" x 11/16"	204 mm	12/120	1.5/15.1
96-708	5/8" x 3/4"	221 mm	12/120	2.1/21.7
96-808	11/16" x 3/4"	221 mm	12/120	2.0/21.0
96-809	3/4" x 13/16"	237 mm	12/72	2.5/15.8
96-813	3/4" x 7/8"	237 mm	12/72	2.7/16.5
96-812	13/16" x 7/8"	237 mm	12/72	2.8/17.1
96-814	7/8" x 15/16"	247 mm	12/72	3.1/19.4
96-811	15/16" x 1"	263 mm	12/72	3.2/20.0





Wrenches



■ Single Open End Spanner (Metric)

Item No.	Size	Length	 
92-501	17 mm	178 mm	12/120
92-502	19 mm	178 mm	12/120
92-504	21 mm	203 mm	12/120
92-505	22 mm	203 mm	12/120
92-506	23 mm	220 mm	12/96
92-507	24 mm	220 mm	12/96
92-508	26 mm	240 mm	6/60
92-509	27 mm	240 mm	6/60
92-510	29 mm	267 mm	6/60
92-511	30 mm	267 mm	6/60
92-512	32 mm	285 mm	4/32
92-513	34 mm	317 mm	4/32
92-514	35 mm	317 mm	4/32
92-515	36 mm	317 mm	4/32
92-516	38 mm	320 mm	2/20
92-517	41 mm	340 mm	2/20
92-518	46 mm	395 mm	2/20
92-519	50 mm	425 mm	2/16
92-520	55 mm	425 mm	2/16
92-521	60 mm	470 mm	1/8
92-522	65 mm	470 mm	1/8
92-523	70 mm	500 mm	1/6
92-524	75 mm	500 mm	1/6



Wrenches

■ Box End Podger Spanner, 45 Degree Offset (Metric)

Item No.	Size	Length	 
92-530	17 mm	335 mm	6/60
92-531	19 mm	335 mm	6/60
92-532	22 mm	354 mm	6/48
92-534	24 mm	388 mm	4/32
92-535	26 mm	388 mm	4/32
92-536	27 mm	406 mm	4/32
92-537	29 mm	393 mm	4/32
92-538	30 mm	414 mm	4/24
92-539	32 mm	414 mm	4/24
92-540	36 mm	476 mm	2/16
92-541	41 mm	532 mm	2/8
92-542	46 mm	532 mm	2/8
92-543	50 mm	553 mm	2/8
92-544	55 mm	610 mm	1/6
92-545	58 mm	610 mm	1/6
92-546	60 mm	610 mm	1/6

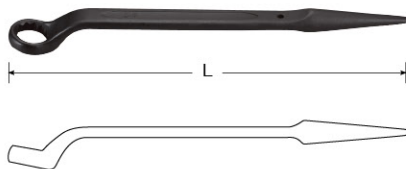



Wrenches

■ Box End Slogging Spanner (Metric)

Item No.	Size	Length	
92-701	27 mm	190 mm	6/48
92-702	30 mm	190 mm	6/48
92-703	32 mm	190 mm	6/48
92-704	34 mm	206 mm	4/32
92-705	36 mm	206 mm	4/32
92-706	38 mm	206 mm	4/32
92-707	41 mm	240 mm	2/20
92-708	42 mm	240 mm	2/20
92-709	46 mm	240 mm	2/20
92-710	50 mm	255 mm	2/16
92-711	55 mm	270 mm	1/12
92-712	60 mm	300 mm	1/10
92-713	65 mm	330 mm	1/6
92-714	70 mm	330 mm	1/6
92-715	75 mm	330 mm	1/6
92-716	80 mm	360 mm	1/4
92-717	85 mm	360 mm	1/4
92-718	90 mm	400 mm	1/4
92-719	95 mm	400 mm	1/4
92-720	100 mm	400 mm	1/4
92-721	105 mm	435 mm	1/2
92-722	110 mm	435 mm	1/2
92-723	115 mm	435 mm	1/2
92-724	120 mm	480 mm	1/2
92-725	125 mm	480 mm	1/2





Wrenches

Box End Slogging Spanner (SAE)

Item No.	Size	Length	
92-730	1-1/16"	190 mm	6/48
92-731	1-1/8"	190 mm	6/48
92-732	1-3/16"	190 mm	6/48
92-733	1-1/4"	190 mm	6/48
92-734	1-5/16"	206 mm	4/32
92-735	1-3/8"	206 mm	4/32
92-736	1-7/16"	206 mm	4/32
92-737	1-1/2"	206 mm	4/32
92-738	1-9/16"	240 mm	2/20
92-739	1-5/8"	240 mm	2/20
92-740	1-11/16"	240 mm	2/20
92-741	1-3/4"	240 mm	2/20
92-742	1-13/16"	240 mm	2/20
92-743	1-7/8"	240 mm	2/20
92-744	1-15/16"	255 mm	2/16
92-745	2"	255 mm	2/16
92-746	2-1/16"	255 mm	2/16
92-747	2-1/8"	255 mm	2/16
92-748	2-3/16"	270 mm	1/12
92-749	2-1/4"	270 mm	1/12
92-750	2-5/16"	270 mm	1/12
92-751	2-3/8"	300 mm	1/10
92-752	2-7/16"	300 mm	1/10
92-753	2-1/2"	300 mm	1/10
92-754	2-9/16"	300 mm	1/10
92-755	2-5/8"	300 mm	1/10
92-756	2-11/16"	300 mm	1/10
92-757	2-3/4"	330 mm	1/6
92-758	2-13/16"	330 mm	1/6
92-759	2-7/8"	330 mm	1/6
92-760	2-15/16"	330 mm	1/6
92-761	3"	330 mm	1/6
92-762	3-1/16"	330 mm	1/6
92-763	3-1/8"	330 mm	1/6
92-764	3-1/4"	360 mm	1/4
92-765	3-3/8"	360 mm	1/4
92-766	3-1/2"	360 mm	1/4
92-767	3-5/8"	400 mm	1/4
92-768	3-3/4"	400 mm	1/4
92-769	3-7/8"	400 mm	1/4
92-770	4"	400 mm	1/4
92-771	4-1/8"	435 mm	1/2
92-772	4-1/4"	435 mm	1/2
92-773	4-1/2"	435 mm	1/2
92-774	4-3/4"	480 mm	1/2
92-775	5"	480 mm	1/2
92-776	5-1/8"	480 mm	1/2







Wrenches



■ Box End Slogging Spanner, 45 Degree Offset (Metric)

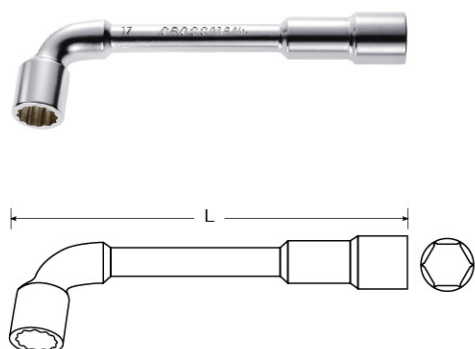

Item No.	Size	Length	 
92-780	24 mm	250 mm	10/10
92-781	27 mm	250 mm	10/10
92-782	30 mm	270 mm	10/10
92-783	32 mm	270 mm	10/10
92-784	36 mm	300 mm	10/10
92-785	38 mm	300 mm	10/10
92-786	41 mm	317 mm	5/5
92-787	43 mm	317 mm	5/5
92-788	46 mm	360 mm	5/5
92-789	50 mm	360 mm	5/5
92-790	55 mm	360 mm	5/5
92-791	60 mm	360 mm	5/5
92-792	65 mm	380 mm	2/2
92-793	70 mm	380 mm	2/2
92-794	75 mm	420 mm	2/2
92-795	80 mm	420 mm	2/2
92-796	85 mm	450 mm	2/2
92-797	90 mm	450 mm	2/2
92-798	95 mm	500 mm	1/1
92-799	100 mm	500 mm	1/1
92-800	105 mm	515 mm	1/1
92-801	110 mm	515 mm	1/1
92-802	115 mm	515 mm	1/1

■ Angle Pipe Wrench - 12 Point x 6 Point (Metric)



Item No.	Size	Length	 
92-670	M6	100 mm	12/240
92-671	M7	100 mm	12/240
92-672	M8	120 mm	12/240
92-673	M9	120 mm	12/240
92-674	M10	127 mm	12/120
92-675	M11	127 mm	12/120
92-676	M12	135 mm	12/120
92-677	M13	140 mm	12/120
92-678	M14	154 mm	6/72
92-679	M15	160 mm	6/72
92-680	M16	185 mm	6/48
92-681	M17	185 mm	6/48
92-682	M18	195 mm	6/48
92-683	M19	195 mm	6/48
92-684	M20	205 mm	2/36
92-685	M21	205 mm	2/36
92-686	M22	225 mm	2/36
92-687	M23	225 mm	2/24
92-688	M24	225 mm	2/24
92-689	M25	225 mm	2/24
92-690	M26	260 mm	1/12
92-691	M27	260 mm	1/12
92-692	M28	270 mm	1/12
92-693	M29	275 mm	1/12
92-694	M30	295 mm	1/12
92-695	M32	305 mm	1/12





Wrench Sets



6 Piece Metric Combination Wrench Set

Item No.



96-079

1/10

Size: 10, 12, 13, 14, 17, 19 mm

▲ Canvas Pouch



9 Piece Metric Combination Wrench Set

Item No.



96-974

1/10

Size: 8, 9, 10, 11, 12, 13, 14, 15, 17 mm

▲ Canvas Pouch



10 Piece Metric Combination Wrench Set

Item No.



96-975

1/8

Size: 10, 11, 12, 13, 14, 15, 17, 19, 21, 22 mm

▲ Canvas Pouch



14 Piece Metric Combination Wrench Set

Item No.



96-081

1/6

Size: 8, 9, 10, 11, 12, 13, 14, 15, 17, 19, 21, 22, 23, 24 mm

▲ Canvas Pouch



14 Piece Metric Combination Wrench Set

Item No.



96-082

1/6

Size: 10, 11, 12, 13, 14, 17, 19, 21, 22, 23, 24, 27, 30, 32 mm

▲ Canvas Pouch





Wrench Sets



6 Piece SAE Combination Wrench Set

Item No.



96-083

1/10

Size: 3/8", 7/16", 1/2", 9/16", 5/8", 3/4"

▲ Canvas Pouch



11 Piece SAE Combination Wrench Set

Item No.



96-084

1/6

Size: 3/8", 7/16", 1/2", 9/16", 5/8", 11/16", 3/4", 13/16", 7/8", 15/16", 1"

▲ Canvas Pouch



14 Piece SAE Combination Wrench Set

Item No.



96-970

1/4

Size: 3/8", 7/16", 1/2", 9/16", 5/8", 11/16", 3/4", 13/16", 7/8", 15/16", 1"
1-1/16", 1-1/8", 1-1/4"

▲ Canvas Pouch



8 Piece Metric Raise Panel Wrench Set

Item No.



96-978

1/1

Size: 33, 34, 35, 36, 38, 41, 46, 50 mm

▲ Canvas Pouch



7 Piece SAE Raise Panel Wrench Set

Item No.



96-977

1/1

Size: 1-5/16", 1-3/8", 1-7/16", 1-1/2", 1-5/8", 1-3/4", 2"

▲ Canvas Pouch





Wrench Sets



9 Piece Metric Thin Combination Wrench Set

Item No.



92-074

1/10

Size: 8, 9, 10, 11, 12, 13, 14, 15, 17 mm

▲ Canvas Pouch



10 Piece Metric Thin Combination Wrench Set

Item No.



92-075

1/8

Size: 10, 11, 12, 13, 14, 15, 17, 19, 21, 22 mm

▲ Canvas Pouch



14 Piece Metric Thin Combination Wrench Set

Item No.



92-081

1/6

Size: 8, 9, 10, 11, 12, 13, 14, 15, 17, 19, 21, 22, 23, 24 mm

▲ Canvas Pouch



14 Piece Metric Thin Combination Wrench Set

Item No.



92-082

1/6

Size: 10, 11, 12, 13, 14, 17, 19, 21, 22, 23, 24, 27, 30, 32 mm

▲ Canvas Pouch



11 Piece SAE Thin Combination Wrench Set

Item No.



92-084

1/6

Size: 3/8", 7/16", 1/2", 9/16", 5/8", 11/16", 3/4", 13/16", 7/8", 15/16", 1"

▲ Canvas Pouch



14 Piece SAE Thin Combination Wrench Set

Item No.



92-070

1/6

Size: 3/8", 7/16", 1/2", 9/16", 5/8", 11/16", 3/4", 13/16", 7/8", 15/16", 1"

1-1/16", 1-1/8", 1-1/4"

▲ Canvas Pouch





Wrench Sets



■ **6 Piece Metric Box End Wrench Set**

Item No.	
96-095	1/6

Size: 10 x 12, 12 x 14, 14 x 17, 17 x 19, 19 x 21, 23 x 26 mm

▲ **Canvas Pouch**



■ **8 Piece Metric Box End Wrench Set**

Item No.	
96-091	1/6

Size: 6 x 7, 8 x 9, 10 x 12, 12 x 14, 14 x 17, 17 x 19, 19 x 21, 22 x 24 mm

▲ **Canvas Pouch**



■ **5 Piece SAE Box End Wrench Set**

Item No.	
96-087	1/6

Size: 1/4" x 5/16", 3/8" x 7/16", 1/2" x 9/16", 5/8" x 11/16", 3/4" x 7/8"

▲ **Canvas Pouch**



■ **7 Piece SAE Box End Wrench Set**

Item No.	
96-088	1/6

Size: 1/4" x 5/16", 3/8" x 7/16", 1/2" x 9/16", 5/8" x 11/16",
3/4" x 7/8", 13/16" x 7/8", 15/16" x 1"

▲ **Canvas Pouch**

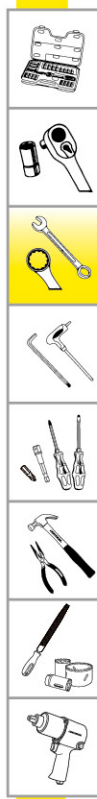

Wrenches

HEX KEY WRENCHES



- P96** Hex Key Wrench
- P98** Ball - Speed Hex Key Wrench
- P99** TORX® Tamper Hex Key Wrench
- P99** T - Handle Hex Key Wrench
- P100** Hex Key Wrenches Set

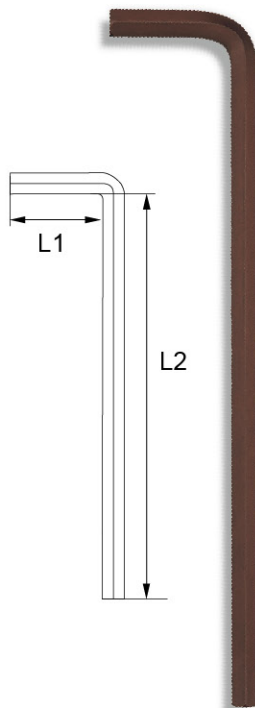
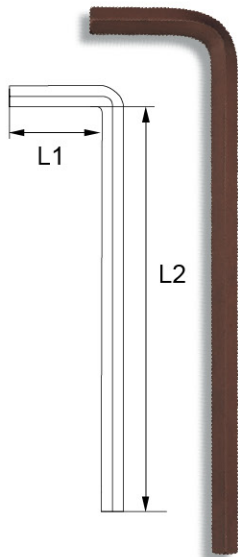
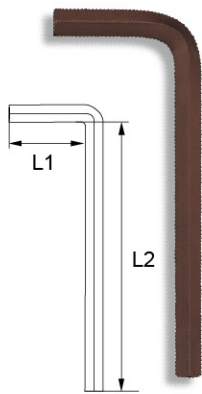

Hex Key Wrenches

Hex Key Wrenches - Standard Length (Metric)

Item No.	Size	L1	L2		kgs
66-104	1.5	14	45	200/2,000	0.2/3.0
66-105	2.0	16	50	200/2,000	0.4/5.0
66-106	2.5	18	56	200/1,500	0.5/5.26
66-107	3.0	20	63	100/1,000	0.48/5.06
66-108	4.0	25	70	50/500	0.55/5.76
66-110	5.0	28	80	50/500	0.75/7.86
66-112	6.0	32	90	25/300	0.8/9.96
66-114	8.0	36	100	20/200	1.2/13.0
66-116	10.0	40	112	12/120	1.31/13.46
66-117	12.0	45	125	10/100	1.65/16.86
66-118	14.0	56	140	8/80	1.67/17.07
66-119	17.0	65	160	4/24	1.9/11.4
66-120	19.0	70	180	4/24	2.59/15.54

Hex Key Wrenches - Long Length (Metric)

Item No.	Size	L1	L2		kgs
66-204	1.5	14	77	200/2,000	0.35/3.76
66-205	2.0	16	83	200/2,000	0.55/5.86
66-206	2.5	18	90	200/2,000	0.87/9.07
66-207	3.0	20	98	100/1,000	0.85/8.76
66-208	4.0	25	106	50/500	0.75/7.76
66-210	5.0	28	118	50/500	1.17/12.07
66-212	6.0	32	137	25/250	1.2/12.36
66-214	8.0	36	156	20/100	1.71/17.47
66-216	10.0	40	170	12/72	1.77/10.62
66-217	12.0	45	207	10/60	2.6/16.27
66-218	14.0	56	230	10/60	3.96/24.43
66-219	17.0	65	250	4/32	2.66/21.75
66-220	19.0	70	280	4/24	3.6/22.18

Hex Key Wrenches - Extra Long Length (Metric)

Item No.	Size	L1	L2		kgs
66-301	1.5	14	90	200/2,000	0.35/3.76
66-302	2.0	16	100	200/2,000	0.67/7.07
66-303	2.5	18	112	200/2,000	1.17/12.02
66-304	3.0	20	126	100/1,000	0.92/9.57
66-305	4.0	25	140	50/500	0.94/9.82
66-306	5.0	28	160	50/500	1.62/16.57
66-308	6.0	32	180	25/250	1.37/14.07
66-310	8.0	36	200	20/200	2.09/21.35
66-311	10.0	40	224	12/120	2.3/23.63
66-312	12.0	45	250	10/80	3.01/24.65
66-313	14.0	56	280	5/40	2.37/19.46
66-314	17.0	63	320	4/24	3.2/19.2
66-315	19.0	70	360	4/16	4.43/17.72

Hex Key Wrenches

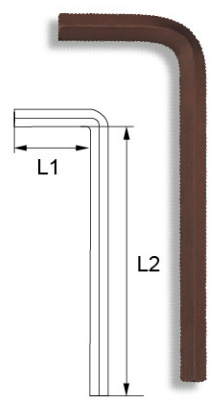

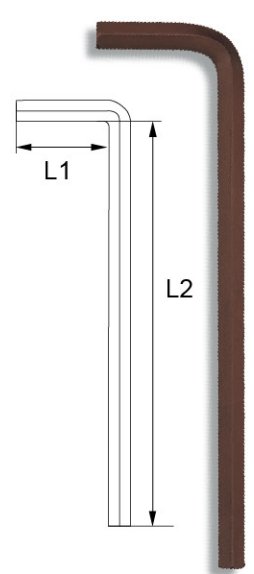

Hex Key Wrenches - Standard Length (SAE)

Item No.	Size	L1	L2		 kgs
66-131	1/16	14	45	200/2,000	0.25/2.76
66-132	5/64	16	50	200/2,000	0.45/4.76
66-133	3/32	18	56	200/2,000	0.65/6.76
66-135	1/8	20	63	100/1,000	0.55/5.76
66-137	5/32	25	70	50/500	0.55/5.76
66-138	3/16	28	80	50/500	0.95/9.86
66-140	1/4	32	90	25/300	0.85/10.56
66-141	5/16	36	100	20/200	1.25/12.86
66-142	3/8	40	108	12/120	1.65/16.82



Hex Key Wrenches - Long Length (SAE)

Item No.	Size	L1	L2		 kgs
66-231	1/16	14	77	200/2,000	0.35/3.76
66-232	5/64	16	82	200/2,000	0.55/5.86
66-233	3/32	18	88	200/2,000	0.87/9.07
66-235	1/8	20	96	100/1,000	0.85/8.76
66-237	5/32	25	105	50/500	0.75/7.76
66-238	3/16	28	114	50/500	1.17/12.07
66-240	1/4	32	135	25/150	1.2/7.2
66-241	5/16	36	156	20/120	1.71/10.26
66-242	3/8	40	170	12/72	1.77/10.62

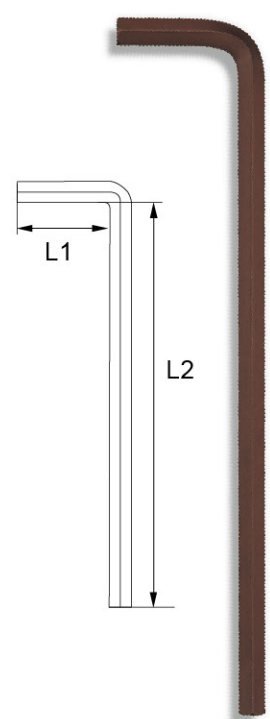

Hex Key Wrenches - Extra Long Length (SAE)

Item No.	Size	L1	L2		 kgs
66-331	1/16	14	90	200/2,000	0.35/3.76
66-332	5/64	16	100	200/2,000	0.67/7.07
66-333	3/32	18	112	200/2,000	1.17/12.07
66-334	1/8	20	126	100/1,000	0.92/9.57
66-335	5/32	25	140	50/500	0.94/9.82
66-336	3/16	28	160	50/500	1.62/16.57
66-338	1/4	32	180	25/250	1.37/14.07
66-339	5/16	36	200	20/200	2.09/21.35
66-340	3/8	40	224	12/72	2.3/14.44
66-341	7/16	42	235	10/40	2.45/10.47
66-342	1/2	45	250	10/40	3.01/12.62
66-343	9/16	56	280	5/40	2.42/19.79
66-344	5/8	63	320	5/30	3.97/24.27
66-345	3/4	70	360	4/16	4.45/17.8

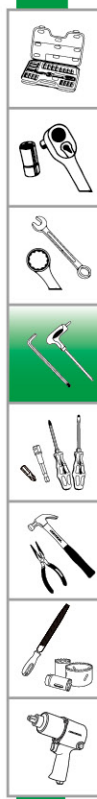

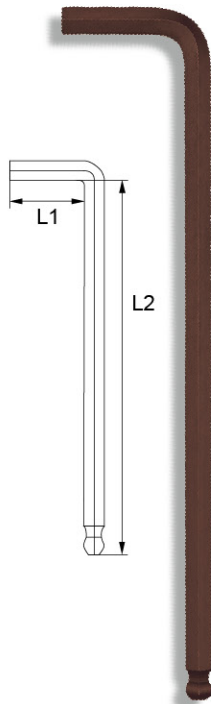
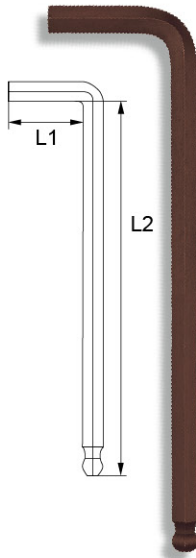

Hex Key Wrenches

■ Ball-Speed® Hex Key Wrenches - Long Length (Metric)

Item No.	Size	L1	L2		kgs
66-404	1.5	14	77	200/2,000	0.35/3.76
66-405	2.0	16	83	200/2,000	0.55/5.86
66-406	2.5	18	90	200/2,000	0.97/10.07
66-407	3.0	20	98	100/1,000	0.75/7.76
66-408	4.0	25	106	50/500	0.72/7.51
66-410	5.0	28	118	50/500	1.27/13.07
66-412	6.0	32	137	25/250	1.06/10.99
66-414	8.0	36	156	20/200	1.71/17.47
66-416	10.0	40	170	12/120	1.77/18.11

■ Ball-Speed® Hex Key Wrenches - Long Length (SAE)

Item No.	Size	L1	L2		kgs
66-431	1/16	14	77	200/2,000	0.35/3.76
66-432	5/64	16	82	200/2,000	0.55/5.86
66-433	3/32	18	88	200/2,000	0.97/10.07
66-435	1/8	20	96	100/1,000	0.75/7.76
66-437	5/32	25	105	50/500	0.72/7.51
66-438	3/16	28	114	50/500	1.27/13.07
66-440	1/4	32	135	25/250	1.06/10.99
66-441	5/16	36	156	20/200	1.71/17.47
66-442	3/8	40	170	20/200	1.77/18.11

■ Ball-Speed® Hex Key Wrenches - Extra Long Length (Metric)



Item No.	Size	L1	L2		kgs
66-501	1.5	14	90	200/2,000	0.35/3.76
66-502	2.0	16	100	200/2,000	0.67/7.07
66-503	2.5	18	112	200/2,000	1.17/12.07
66-504	3.0	20	126	100/1,000	0.92/9.57
66-505	4.0	25	140	50/500	0.92/9.57
66-506	5.0	28	160	50/500	1.67/17.07
66-508	6.0	32	180	25/250	1.37/14.07
66-510	8.0	36	200	20/200	2.09/21.35
66-511	10.0	40	224	12/72	2.3/14.44

■ Ball-Speed® Hex Key Wrenches - Extra Long Length (SAE)

Item No.	Size	L1	L2		kgs
66-531	1/16	14	90	200/2,000	0.35/3.76
66-532	5/64	16	100	200/2,000	0.67/7.07
66-533	3/32	18	112	200/2,000	1.17/12.07
66-534	1/8	20	126	100/1,000	0.92/9.57
66-535	5/32	25	140	50/500	0.92/9.57
66-536	3/16	28	160	50/500	1.67/17.07
66-538	1/4	32	180	25/250	1.37/14.07
66-539	5/16	36	200	20/200	2.09/21.35
66-540	3/8	40	224	12/72	2.3/14.44



Hex Key Wrenches

TORX® Tamper Proof Key Wrenches - Long Length

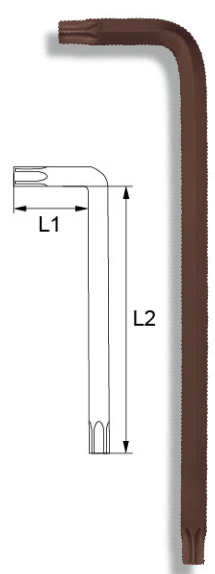
Item No.	Size	L1	L2	 	 kgs
66-601	T10	14	77	200/2,000	1.1/10.8
66-602	T15	16	83	200/2,000	1.2/13.0
66-603	T20	18	90	200/2,000	2.3/23.1
66-604	T25	20	98	100/1,000	1.3/13.5
66-605	T27	25	106	50/500	1.1/11.5
66-606	T30	28	118	50/500	1.3/13.6
66-607	T40	32	137	25/250	1.1/11.6
66-608	T45	36	156	20/200	1.7/17.5
66-609	T50	40	170	12/120	1.8/17.9



TORX® Tamper Proof Key Wrenches - Extra Long Length

Item No.	Size	L1	L2	 	 kgs
66-631	T10	14	90	200/2,000	1.3/13.0
66-632	T15	16	100	200/2,000	1.5/15.1
66-633	T20	18	112	200/2,000	2.7/27.0
66-634	T25	20	126	100/1,000	1.6/16.0
66-635	T27	25	140	50/500	1.4/15.0
66-636	T30	28	160	50/500	1.6/16.6
66-637	T40	32	180	25/250	1.3/14.0
66-638	T45	36	200	20/200	2.0/21.0
66-639	T50	40	224	12/120	2.3/23.6

"T" Handle Hex Key Wrenches (Metric)

Item No.	Size	 	 kgs
66-900	2mm x 110mm	6/120	0.25/3
66-901	2.5mm x 110mm	6/120	0.25/5
66-902	3mm x 110mm	6/120	0.25/5
66-903	4mm x 110mm	6/120	0.25/5
66-904	5mm x 160mm	6/60	0.8/8
66-905	6mm x 160mm	6/60	0.8/8
66-906	7mm x 160mm	6/60	0.8/8
66-907	8mm x 200mm	6/60	1.8/8
66-908	10mm x 215mm	6/48	2/16.5
66-909	12mm x 215mm	6/48	2/16.5

"T" Handle TORX® + TORX® Tamper Proof Key Wrenches

Item No.	Size	 	 kgs
66-910	T-8 x 110mm	6/120	0.25/5
66-911	T-9 x 110mm	6/120	0.25/5
66-912	T-10 x 110mm	6/120	0.25/5
66-913	T-15 x 110mm	6/120	0.25/5
66-914	T-20 x 110mm	6/120	0.25/5
66-915	T-25 x 160mm	6/60	0.8/8
66-916	T-27 x 160mm	6/60	0.8/8
66-917	T-30 x 160mm	6/60	0.8/8
66-918	T-40 x 185mm	6/60	1.8/18
66-919	T-45 x 215mm	6/48	1.8/15.4
66-920	T-50 x 215mm	6/48	1.8/15.4
66-921	T-55 x 215mm	6/48	1.8/15.4



Hex Key Wrenches



Ball-Speed® Hex Key Wrench Set - Extra Long Length (Metric) - 9 Pcs.

Item No.		kgs
66-099	6/36	3.1/26.0
⊕ 1.5, 2, 2.5, 3, 4, 5, 6, 8, 10 mm		



Ball-Speed® Hex Key Wrench Set - Extra Long Length (SAE) - 9 Pcs.

Item No.		kgs
66-199	6/36	3.1/26.0
⊕ 1/16", 5/64", 3/32", 1/8", 5/32", 3/16", 1/4", 5/16", 3/8"		



Ball-Speed® Hex Key Wrench Set 3-Way Duplex Grip Holder - Extra Long Length (Metric) - 9 Pcs.

Item No.		kgs
66-399	6/24	3.3/21.0
⊕ 1.5, 2, 2.5, 3, 4, 5, 6, 8, 10 mm		



Ball-Speed® Hex Key Wrench Set 3-Way Duplex Grip Holder - Extra Long Length (SAE) - 9 Pcs.

Item No.		kgs
66-499	6/24	3.3/21.0
⊕ 1/16", 5/64", 3/32", 1/8", 5/32", 3/16", 1/4", 5/16", 3/8"		

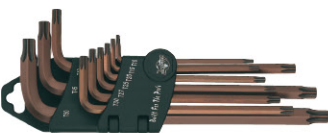

TORX® Tamper Proof Key Wrench Set - Long Length - 9 Pcs.

Item No.		kgs
66-095	6/36	2.5/20.5
⊕ T10, T15, T20, T25, T27, T30, T40, T45, T50		



TORX® Tamper Proof Key Wrench Set - Extra Long Length - 9 Pcs.

Item No.		kgs
66-096	6/36	3.1/26.0
⊕ T10, T15, T20, T25, T27, T30, T40, T45, T50		



"T" Handle TORX® Tamper Proof Key Wrench Set - 7 Pcs.

Item No.		kgs
66-899	1/6	1.7/11.0
⊕ T20, T25, T30, T40, T45, T50, T55		



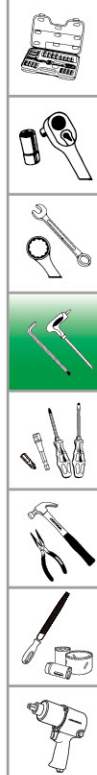

Hex Key Wrenches



Hex Key Wrench Set - Standard Length (Metric) - 9 Pcs.

Item No.		kgs
66-091	6/36	1.9/16.0

○ 1.5, 2, 2.5, 3, 4, 5, 6, 8, 10 mm



Hex Key Wrench Set - Standard Length (SAE) - 9 Pcs.

Item No.		kgs
66-191	6/36	1.9/16.0

○ 1/16", 5/64", 3/32", 1/8", 5/32", 3/16", 1/4", 5/16", 3/8"

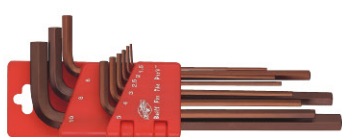

Hex Key Wrench Set - Long Length (Metric) - 9 Pcs.

Item No.		kgs
66-092	6/36	2.5/20.5

○ 1.5, 2, 2.5, 3, 4, 5, 6, 8, 10 mm



Hex Key Wrench Set - Long Length (SAE) - 9 Pcs.

Item No.		kgs
66-192	6/36	2.5/20.5

○ 1/16", 5/64", 3/32", 1/8", 5/32", 3/16", 1/4", 5/16", 3/8"



Hex Key Wrench Set - Extra Long Length (Metric) - 9 Pcs.

Item No.		kgs
66-093	6/36	3.1/26.0

○ 1.5, 2, 2.5, 3, 4, 5, 6, 8, 10 mm



Hex Key Wrench Set - Extra Long Length (SAE) - 9 Pcs.

Item No.		kgs
66-193	6/36	3.1/26.0

○ 1/16", 5/64", 3/32", 1/8", 5/32", 3/16", 1/4", 5/16", 3/8"

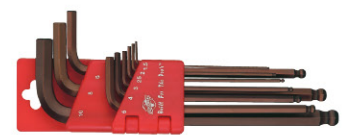

Ball-Speed® Hex Key Wrench Set - Long Length (Metric) - 9 Pcs.

Item No.		kgs
66-098	6/36	2.5/20.5

⊗ 1.5, 2, 2.5, 3, 4, 5, 6, 8, 10 mm



Ball-Speed® Hex Key Wrench Set - Long Length (SAE) - 9 Pcs.

Item No.		kgs
66-198	6/36	2.5/20.5

⊗ 1/16", 5/64", 3/32", 1/8", 5/32", 3/16", 1/4", 5/16", 3/8"

SCREWDRIVERS FASTENER DRIVE TOOLS



P103 Screwdrivers

P119 Fastener Drive Tool

P122 Insert Bits

P126 Power Bits

P132 Fastener Drive Tool Sets

Screwdrivers

Hex Acetate Handle Screwdrivers - Slotted

Item No.	Pt. Size	Size (DxL)		Pkg	kgs
		inch	mm		
46-929	3 mm	1/8" x 3"	3 x 75	12/600	0.3/16.0
46-930	3 mm	1/8" x 4"	3 x 100	12/600	0.4/17.5
46-983	4 mm	5/32" x 3"	4 x 75	12/600	0.4/20.0
46-937	4 mm	5/32" x 4"	4 x 100	12/600	0.4/20.3
46-938	4 mm	5/32" x 6"	4 x 150	12/600	0.5/23.8
46-939	4 mm	5/32" x 8"	4 x 200	12/600	0.6/27.4
46-940	4 mm	5/32" x 12"	4 x 300	12/240	0.7/14.2
46-941	5 mm	3/16" x 3"	5 x 75	12/300	0.8/20.0
46-942	5 mm	3/16" x 4"	5 x 100	12/300	0.9/22.1
46-943	5 mm	3/16" x 6"	5 x 150	12/300	1.0/24.3
46-944	5 mm	3/16" x 8"	5 x 200	12/240	1.1/21.4
46-430	5 mm	3/16" x 10"	5 x 250	12/240	1.0/19.3
46-945	5 mm	3/16" x 12"	5 x 300	12/240	1.2/24.3
46-946	6 mm	1/4" x 1-1/2"	6 x 38 (Stubby)	12/300	0.4/11.0
46-947	6 mm	1/4" x 4"	6 x 100	12/240	1.2/23.0
46-948	6 mm	1/4" x 6"	6 x 150	12/120	1.3/13.0
46-949	6 mm	1/4" x 8"	6 x 200	12/120	1.4/13.6
46-950	6 mm	1/4" x 12"	6 x 300	12/120	1.6/15.6
46-431	8 mm	5/16" x 6"	8 x 150	12/120	2.1/21.8
46-432	8 mm	5/16" x 8"	8 x 200	12/120	2.4/24.4
46-433	8 mm	5/16" x 10"	8 x 250	12/96	2.6/21.5
46-434	8 mm	5/16" x 12"	8 x 300	12/96	2.8/23.0

Slotted

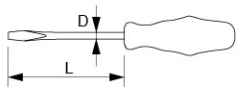

Hex Acetate Handle Screwdrivers - Slotted w/Hex Bolster

Item No.	Pt. Size	Size (DxL)		Pkg	kgs
		inch	mm		
46-911	5 mm	3/16" x 3"	5 x 75	12/300	0.8/20.0
46-912	5 mm	3/16" x 4"	5 x 100	12/300	0.9/22.1
46-913	6 mm	1/4" x 4"	6 x 100	12/240	1.2/23.0
46-914	6 mm	1/4" x 6"	6 x 150	12/120	1.3/13.0
46-915	8 mm	5/16" x 6"	8 x 150	12/120	2.1/21.8
46-916	8 mm	5/16" x 8"	8 x 200	12/120	2.4/24.4

Slotted

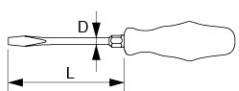

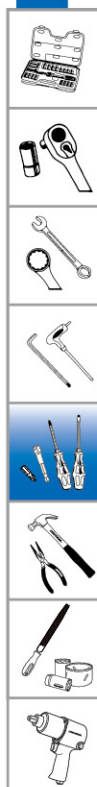

** Crossman platinum shaft; hardened but high ductility.
 ** Handle is made of eco-friendly acetate w/fiber.
 ** Ideal for auto, agricultural machinery & equipments etc.



Screwdrivers



■ Hex Acetate Handle Screwdrivers - Phillips

Item No.	Pt. Size	Size (DxL)			 kgs
		inch	mm		
46-960	PH0	1/8" x 3"	3 x 75	12/600	0.3/16.0
46-961	PH0	1/8" x 4"	3 x 100	12/600	0.4/17.5
46-984	PH0	5/32" x 3"	4 x 75	12/600	0.4/20.0
46-962	PH0	5/32" x 4"	4 x 100	12/600	0.4/20.3
46-963	PH0	5/32" x 6"	4 x 150	12/600	0.5/23.8
46-964	PH0	5/32" x 8"	4 x 200	12/600	0.6/27.4
46-965	PH0	5/32" x 12"	4 x 300	12/240	0.7/14.2
46-966	PH1	3/16" x 3"	5 x 75	12/300	0.8/20.0
46-967	PH1	3/16" x 4"	5 x 100	12/300	0.9/22.1
46-968	PH1	3/16" x 6"	5 x 150	12/300	1.0/24.3
46-969	PH1	3/16" x 8"	5 x 200	12/240	1.1/21.4
46-435	PH1	3/16" x 10"	5 x 250	12/240	1.0/19.3
46-970	PH1	3/16" x 12"	5 x 300	12/240	1.2/24.3
46-971	PH2	1/4" x 1-1/2"	6 x 38 (Stubby)	12/300	0.4/11.0
46-972	PH2	1/4" x 4"	6 x 100	12/240	1.2/23.0
46-973	PH2	1/4" x 6"	6 x 150	12/120	1.3/13.0
46-974	PH2	1/4" x 8"	6 x 200	12/120	1.4/13.6
46-975	PH2	1/4" x 12"	6 x 300	12/120	1.6/15.6
46-436	PH3	5/16" x 6"	8 x 150	12/120	2.1/21.8
46-437	PH3	5/16" x 8"	8 x 200	12/120	2.4/24.4
46-438	PH3	5/16" x 10"	8 x 250	12/96	2.6/21.5
46-439	PH3	5/16" x 12"	8 x 300	12/96	2.8/23.0

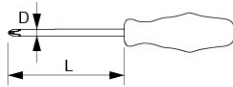
 Phillips



■ Hex Acetate Handle Screwdrivers - Phillips w/Hex Bolster

Item No.	Pt. Size	Size (DxL)			 kgs
		inch	mm		
46-921	PH1	3/16" x 3"	5 x 75	12/300	0.8/20.0
46-922	PH1	3/16" x 4"	5 x 100	12/300	0.9/22.1
46-923	PH2	1/4" x 4"	6 x 100	12/240	1.2/23.0
46-924	PH2	1/4" x 6"	6 x 150	12/240	1.3/13.0
46-925	PH3	5/16" x 6"	8 x 150	12/120	2.1/21.8
46-926	PH3	5/16" x 8"	8 x 200	12/120	2.4/24.4

 Phillips

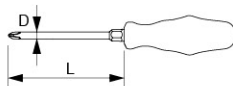

- ** Crossman platinum shaft; hardened but high ductility.
- ** Handle is made of eco-friendly acetate w/fiber.
- ** Ideal for auto, agricultural machinery & equipments etc.

Screwdrivers

Line Color Acetate Handle Screwdrivers - Slotted

Item No.	Pt. Size	Size (DxL)		Pcs/Box	Pcs/Case	kgs
		inch	mm			
46-572	3 mm	1/8" x 2"	3 x 50	12/240		0.5/11.1
46-558	3 mm	1/8" x 3"	3 x 75	12/240		0.5/11.1
46-905	3 mm	1/8" x 4"	3 x 100	12/240		0.6/11.5
46-573	4 mm	5/32" x 3"	4 x 75	12/240		0.6/12.0
46-575	4 mm	5/32" x 4"	4 x 100	12/240		0.6/12.5
46-907	4 mm	5/32" x 6"	4 x 150	12/120		0.7/7.2
46-507	4 mm	5/32" x 8"	4 x 200	12/120		0.8/8.0
46-508	4 mm	5/32" x 10"	4 x 250	12/96		0.9/8.0
46-509	4 mm	5/32" x 12"	4 x 300	12/96		1.0/8.5
46-511	5 mm	3/16" x 3"	5 x 75	12/240		1.0/20.1
46-512	5 mm	3/16" x 4"	5 x 100	12/240		1.0/21.0
46-513	5 mm	3/16" x 6"	5 x 150	12/120		1.1/11.8
46-514	5 mm	3/16" x 8"	5 x 200	12/96		1.2/10.5
46-515	5 mm	3/16" x 10"	5 x 250	12/96		1.4/12.0
46-516	5 mm	3/16" x 12"	5 x 300	12/96		1.5/13.0
46-521	6 mm	1/4" x 1-1/2"	6 x 38 (Stubby)	12/240		0.5/10.5
46-522	6 mm	1/4" x 4"	6 x 100	12/120		1.2/12.4
46-523	6 mm	1/4" x 5"	6 x 125	12/120		1.3/13.8
46-524	6 mm	1/4" x 6"	6 x 150	12/120		1.3/13.9
46-525	6 mm	1/4" x 8"	6 x 200	12/96		1.5/12.6
46-526	6 mm	1/4" x 10"	6 x 250	12/96		1.3/13.5
46-527	6 mm	1/4" x 12"	6 x 300	12/96		1.8/14.8
46-528	8 mm	5/16" x 6"	8 x 150	12/120		1.8/18.0
46-529	8 mm	5/16" x 8"	8 x 200	12/96		1.8/19.5
46-530	8 mm	5/16" x 10"	8 x 250	12/96		2.2/22.0
46-531	8 mm	5/16" x 12"	8 x 300	12/96		2.4/24.0
46-574	10 mm	3/8" x 8"	10 x 200	6/60		2.1/21.0
46-576	10 mm	3/8" x 10"	10 x 250	6/60		2.3/23.0
46-577	10 mm	3/8" x 12"	10 x 300	6/60		2.5/25.0

Slotted

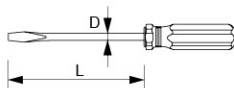

Line Color Acetate Handle Screwdrivers - Slotted w/Hex Bolster

Item No.	Pt. Size	Size (DxL)		Pcs/Box	Pcs/Case	kgs
		inch	mm			
46-630	5 mm	3/16" x 3"	5 x 75	12/300		0.8/20.0
46-631	5 mm	3/16" x 4"	5 x 100	12/300		0.9/22.1
46-632	6 mm	1/4" x 4"	6 x 100	12/240		1.2/23.0
46-633	6 mm	1/4" x 6"	6 x 150	12/240		1.2/24.0
46-634	8 mm	5/16" x 6"	8 x 150	6/120		0.7/13.5
46-635	8 mm	5/16" x 8"	8 x 200	6/120		0.7/14.5
46-636	10 mm	3/8" x 8"	10 x 200	6/60		2.4/24.0
46-637	10 mm	3/8" x 10"	10 x 250	6/48		2.6/20.8

Slotted

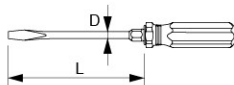

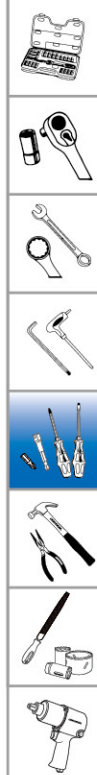

** Crossman platinum shaft; hardened but high ductility.
 ** Handle is made of eco-friendly acetate w/fiber.
 ** Ideal for auto repairing & mechanical & machinery etc.



Screwdrivers

Line Color Acetate Handle Screwdrivers - Phillips

Item No.	Pt. Size	Size (DxL)			 kgs
		inch	mm		
46-541	PH0	1/8" x 2"	3 x 50	12/240	0.5/11.1
46-542	PH0	1/8" x 3"	3 x 75	12/240	0.5/11.1
46-543	PH0	1/8" x 4"	3 x 100	12/240	0.6/11.5
46-544	PH0	5/32" x 3"	4 x 75	12/240	0.6/12.0
46-545	PH0	5/32" x 4"	4 x 100	12/240	0.6/12.5
46-546	PH0	5/32" x 6"	4 x 150	12/120	0.7/7.2
46-547	PH0	5/32" x 8"	4 x 200	12/120	0.8/8.0
46-548	PH0	5/32" x 10"	4 x 250	12/96	0.9/8.0
46-549	PH0	5/32" x 12"	4 x 300	12/96	1.0/8.5
46-551	PH1	3/16" x 3"	5 x 75	12/240	1.0/20.1
46-552	PH1	3/16" x 4"	5 x 100	12/240	1.0/21.0
46-553	PH1	3/16" x 6"	5 x 150	12/120	1.1/11.8
46-554	PH1	3/16" x 8"	5 x 200	12/96	1.2/10.5
46-555	PH1	3/16" x 10"	5 x 250	12/96	1.4/12.0
46-556	PH1	3/16" x 12"	5 x 300	12/96	1.5/13.0
46-561	PH2	1/4" x 1-1/2"	6 x 38 (Stubby)	12/240	0.5/10.5
46-562	PH2	1/4" x 4"	6 x 100	12/120	1.2/12.4
46-563	PH2	1/4" x 5"	6 x 125	12/120	1.3/13.8
46-564	PH2	1/4" x 6"	6 x 150	12/120	1.3/13.9
46-565	PH2	1/4" x 8"	6 x 200	12/96	1.5/12.6
46-566	PH2	1/4" x 10"	6 x 250	12/96	1.3/13.5
46-567	PH2	1/4" x 12"	6 x 300	12/96	1.8/14.8
46-568	PH3	5/16" x 6"	8 x 150	12/120	1.8/18.0
46-569	PH3	5/16" x 8"	8 x 200	12/96	1.8/19.5
46-570	PH3	5/16" x 10"	8 x 250	12/96	2.2/22.0
46-571	PH3	5/16" x 12"	8 x 300	12/96	2.4/24.0
46-595	PH4	3/8" x 8"	10 x 200	6/60	2.1/21.0
46-596	PH4	3/8" x 10"	10 x 250	6/60	2.3/23.0
46-597	PH4	3/8" x 12"	10 x 300	6/60	2.5/25.0

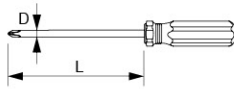

 Phillips

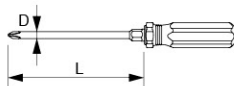

 Phillips



Line Color Acetate Handle Screwdrivers - Phillips w/Hex Bolster

Item No.	Pt. Size	Size (DxL)			 kgs
		inch	mm		
46-640	PH1	3/16" x 3"	5 x 75	12/300	0.8/20.0
46-641	PH1	3/16" x 4"	5 x 100	12/300	0.9/22.1
46-642	PH2	1/4" x 4"	6 x 100	12/240	1.2/23.0
46-643	PH2	1/4" x 6"	6 x 150	12/240	1.2/24.0
46-644	PH3	5/16" x 6"	8 x 150	6/120	0.7/13.5
46-645	PH3	5/16" x 8"	8 x 200	6/120	0.7/14.5
46-646	PH4	3/8" x 8"	10 x 200	6/60	2.4/24.0
46-647	PH4	3/8" x 10"	10 x 250	6/48	2.6/20.8

** Crossman platinum shaft; hardened but high ductility.
 ** Handle is made of eco-friendly acetate w/fiber.
 ** Ideal for auto repairing & mechanical & machinery etc.

Screwdrivers

Line Color Acetate Handle Screwdrivers - TORX®

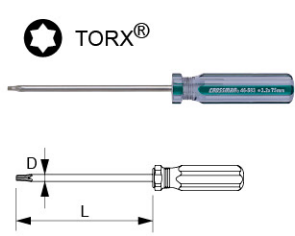

Item No.	Pt. Size	Size (DxL)		Pkg	kgs
		inch	mm		
46-581	T5	1/8" x 3"	3 x 75	12/240	0.5/11.1
46-582	T6	1/8" x 3"	3 x 75	12/240	0.5/11.1
46-583	T7	1/8" x 3"	3 x 75	12/240	0.5/11.1
46-584	T8	1/8" x 3"	3 x 75	12/240	0.5/11.1
46-585	T9	1/8" x 3"	3 x 75	12/240	0.5/11.1
46-586	T10	5/32" x 3"	4 x 75	12/240	0.6/12.0
46-587	T15	5/32" x 3"	4 x 75	12/240	0.6/12.0
46-588	T20	5/32" x 3"	4 x 75	12/240	0.6/12.0
46-589	T25	3/16" x 4"	5 x 100	12/240	1.0/21.0
46-590	T27	3/16" x 4"	5 x 100	12/240	1.0/21.0
46-591	T30	1/4" x 4"	6 x 100	12/120	1.2/12.4

** Crossman platinum shaft; hardened but high ductility.
 ** Handle is made of eco-friendly acetate w/fiber.
 ** Ideal for auto repairing & mechanical & machinery etc.

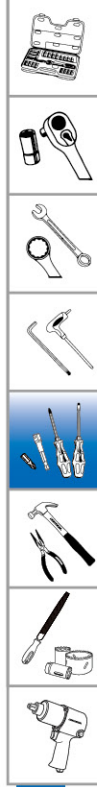

Screwdrivers



Advanced Cushion Grip/Acetate Handle Screwdrivers - Slotted

Item No.	Pt. Size	Size (DxL)			
		inch	mm		
46-710	3 mm	1/8" x 2"	3 x 50	12/240	0.5/11.1
46-711	3 mm	1/8" x 3"	3 x 75	12/240	0.5/11.1
46-712	3 mm	1/8" x 4"	3 x 100	12/240	0.6/11.5
46-713	4 mm	5/32" x 3"	4 x 75	12/240	0.6/12.0
46-714	4 mm	5/32" x 4"	4 x 100	12/240	0.6/12.5
46-715	4 mm	5/32" x 6"	4 x 150	12/120	0.7/7.2
46-716	4 mm	5/32" x 8"	4 x 200	12/120	0.8/8.0
46-717	4 mm	5/32" x 10"	4 x 250	12/96	0.9/8.0
46-718	4 mm	5/32" x 12"	4 x 300	12/96	1.0/8.5
46-719	5 mm	3/16" x 3"	5 x 75	12/240	1.0/20.1
46-720	5 mm	3/16" x 4"	5 x 100	12/240	1.0/21.0
46-721	5 mm	3/16" x 6"	5 x 150	12/120	1.1/11.8
46-722	5 mm	3/16" x 8"	5 x 200	12/96	1.2/10.5
46-723	5 mm	3/16" x 10"	5 x 250	12/96	1.4/12.0
46-724	5 mm	3/16" x 12"	5 x 300	12/96	1.5/13.0
46-725	6 mm	1/4" x 1-1/2"	6 x 38 (Stubby)	12/240	0.5/10.5
46-726	6 mm	1/4" x 4"	6 x 100	12/120	1.2/12.4
46-727	6 mm	1/4" x 5"	6 x 125	12/120	1.3/13.8
46-728	6 mm	1/4" x 6"	6 x 150	12/120	1.3/13.9
46-729	6 mm	1/4" x 8"	6 x 200	12/96	1.5/12.6
46-730	6 mm	1/4" x 10"	6 x 250	12/96	1.3/13.5
46-731	6 mm	1/4" x 12"	6 x 300	12/96	1.8/14.8
46-732	8 mm	5/16" x 6"	8 x 150	12/120	1.8/18.0
46-733	8 mm	5/16" x 8"	8 x 200	12/96	1.8/19.5
46-734	8 mm	5/16" x 10"	8 x 250	12/96	2.2/22.0
46-735	8 mm	5/16" x 12"	8 x 300	12/96	2.4/24.0
46-736	10 mm	3/8" x 8"	10 x 200	6/60	2.1/21.0
46-737	10 mm	3/8" x 10"	10 x 250	6/60	2.3/23.0
46-738	10 mm	3/8" x 12"	10 x 300	6/60	2.5/25.0

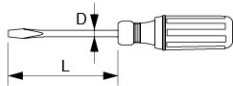
 Slotted



Advanced Cushion Grip/Acetate Handle Screwdriver - Slotted w/Hex Bolster

Item No.	Pt. Size	Size (DxL)			
		inch	mm		
46-740	5 mm	3/16" x 3"	5 x 75	12/240	1.0/20.1
46-741	5 mm	3/16" x 4"	5 x 100	12/240	1.0/21.0
46-742	6 mm	1/4" x 4"	6 x 100	12/120	1.2/12.4
46-743	6 mm	1/4" x 6"	6 x 150	12/120	1.3/14.0
46-744	8 mm	5/16" x 6"	8 x 150	12/120	1.8/18.0
46-745	8 mm	5/16" x 8"	8 x 200	12/96	1.8/19.5
46-746	10 mm	3/8" x 8"	10 x 200	6/60	2.1/21.0
46-747	10 mm	3/8" x 10"	10 x 250	6/60	2.3/23.0

 Slotted

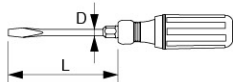

** Crossman platinum shaft; hardened but high ductility.
 ** Handle is made of cushion-grip material for more powerful drive.
 ** Ideal for construction or furnishing work etc.

Screwdrivers

Advanced Cushion Grip/Acetate Handle Screwdrivers - Phillips

Item No.	Pt. Size	Size (DxL)		Pkg	Kgs
		inch	mm		
46-750	PH0	1/8" x 2"	3 x 50	12/240	0.5/11.1
46-751	PH0	1/8" x 3"	3 x 75	12/240	0.5/11.1
46-752	PH0	1/8" x 4"	3 x 100	12/240	0.6/11.5
46-753	PH0	5/32" x 3"	4 x 75	12/240	0.6/12.0
46-754	PH0	5/32" x 4"	4 x 100	12/240	0.6/12.5
46-755	PH0	5/32" x 6"	4 x 150	12/120	0.7/7.2
46-756	PH0	5/32" x 8"	4 x 200	12/120	0.8/8.0
46-757	PH0	5/32" x 10"	4 x 250	12/96	0.9/8.0
46-758	PH0	5/32" x 12"	4 x 300	12/96	1.0/8.5
46-759	PH1	3/16" x 3"	5 x 75	12/240	1.0/20.1
46-760	PH1	3/16" x 4"	5 x 100	12/240	1.0/21.0
46-761	PH1	3/16" x 6"	5 x 150	12/120	1.1/11.8
46-762	PH1	3/16" x 8"	5 x 200	12/96	1.2/10.5
46-763	PH1	3/16" x 10"	5 x 250	12/96	1.4/12.0
46-764	PH1	3/16" x 12"	5 x 300	12/96	1.5/13.0
46-765	PH2	1/4" x 1-1/2"	6 x 38 (Stubby)	12/240	0.5/10.5
46-766	PH2	1/4" x 4"	6 x 100	12/120	1.2/12.4
46-767	PH2	1/4" x 5"	6 x 125	12/120	1.3/13.8
46-768	PH2	1/4" x 6"	6 x 150	12/120	1.3/13.9
46-769	PH2	1/4" x 8"	6 x 200	12/96	1.5/12.6
46-770	PH2	1/4" x 10"	6 x 250	12/96	1.3/13.5
46-771	PH2	1/4" x 12"	6 x 300	12/96	1.8/14.8
46-772	PH3	5/16" x 6"	8 x 150	12/120	1.8/18.0
46-773	PH3	5/16" x 8"	8 x 200	12/96	1.8/19.5
46-774	PH3	5/16" x 10"	8 x 250	12/96	2.2/22.0
46-775	PH3	5/16" x 12"	8 x 300	12/96	2.4/24.0
46-776	PH4	3/8" x 8"	10 x 200	6/60	2.1/21.0
46-777	PH4	3/8" x 10"	10 x 250	6/60	2.3/23.0
46-778	PH4	3/8" x 12"	10 x 300	6/60	2.5/25.0

Phillips

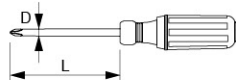

Phillips

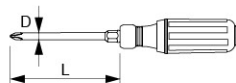

Advanced Cushion Grip/Acetate Handle Screwdriver - Phillips w/Hex Bolster

Item No.	Pt. Size	Size (DxL)		Pkg	Kgs
		inch	mm		
46-780	PH1	3/16" x 3"	5 x 75	12/240	1.0/20.1
46-781	PH1	3/16" x 4"	5 x 100	12/240	1.0/21.0
46-782	PH2	1/4" x 4"	6 x 100	12/120	1.2/12.4
46-783	PH2	1/4" x 6"	6 x 150	12/120	1.3/14.0
46-784	PH3	5/16" x 6"	8 x 150	12/120	1.8/18.0
46-785	PH3	5/16" x 8"	8 x 200	12/96	1.8/19.5
46-786	PH4	3/8" x 8"	10 x 200	6/60	2.1/21.0
46-787	PH4	3/8" x 10"	10 x 250	6/60	2.3/23.0

** Crossman platinum shaft; hardened but high ductility.
 ** Handle is made of cushion-grip material for more powerful drive.
 ** Ideal for construction or furnishing work etc.

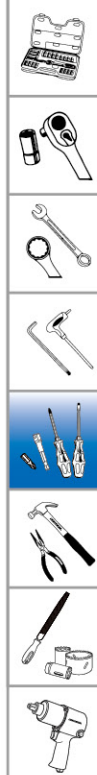

Screwdrivers

Sheffield Acetate Handle Screwdrivers - Slotted

Item No.	Pt. Size	Size (DxL)		Pcs/Box	Kgs
		inch	mm		
46-303	3 mm	1/8" x 3"	3 x 75	12/600	0.3/16.0
46-304	3 mm	1/8" x 4"	3 x 100	12/600	0.4/18.0
46-410	4 mm	5/32" x 3"	4 x 75	12/600	0.4/20.0
46-305	4 mm	5/32" x 4"	4 x 100	12/600	0.4/20.3
46-306	4 mm	5/32" x 6"	4 x 150	12/600	0.5/23.8
46-307	4 mm	5/32" x 8"	4 x 200	12/600	0.6/27.4
46-308	4 mm	5/32" x 12"	4 x 300	12/240	0.7/14.2
46-411	5 mm	3/16" x 3"	5 x 75	12/300	0.8/21.5
46-310	5 mm	3/16" x 4"	5 x 100	12/300	0.9/22.1
46-311	5 mm	3/16" x 6"	5 x 150	12/300	1.0/24.3
46-312	5 mm	3/16" x 8"	5 x 200	12/300	1.1/26.8
46-326	5 mm	3/16" x 10"	5 x 250	12/240	1.0/20.3
46-313	5 mm	3/16" x 12"	5 x 300	12/240	1.0/20.3
46-412	6 mm	1/4" x 4"	6 x 100	12/120	1.3/13.2
46-413	6 mm	1/4" x 6"	6 x 150	12/120	1.3/13.4
46-317	6 mm	1/4" x 8"	6 x 200	12/120	1.4/13.6
46-327	6 mm	1/4" x 10"	6 x 250	12/120	1.4/15.0
46-318	6 mm	1/4" x 12"	6 x 300	12/120	1.6/15.6
46-414	8 mm	5/16" x 6"	8 x 150	6/60	1.6/16.0
46-415	8 mm	5/16" x 8"	8 x 200	6/60	1.8/18.0
46-416	8 mm	5/16" x 10"	8 x 250	6/60	2.0/20.0
46-321	8 mm	5/16" x 12"	8 x 300	6/60	2.1/21.0
46-417	10 mm	3/8" x 8"	10 x 200	6/60	2.1/21.0
46-418	10 mm	3/8" x 10"	10 x 250	6/60	2.3/23.0
46-323	10 mm	3/8" x 12"	10 x 300	6/60	2.5/25.0

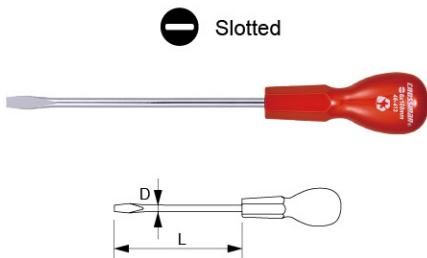

Sheffield Acetate Handle Screwdrivers - Slotted w/Hex Bolster

Item No.	Pt. Size	Size (DxL)		Pcs/Box	Kgs
		inch	mm		
46-309	5 mm	3/16" x 3"	5 x 75	12/300	0.8/20.0
46-419	5 mm	3/16" x 4"	5 x 100	12/300	0.9/22.1
46-315	6 mm	1/4" x 4"	6 x 100	12/240	1.2/23.0
46-316	6 mm	1/4" x 6"	6 x 150	12/240	1.2/24.0
46-319	8 mm	5/16" x 6"	8 x 150	6/120	0.7/13.5
46-320	8 mm	5/16" x 8"	8 x 200	6/120	0.7/14.5
46-322	10 mm	3/8" x 8"	10 x 200	6/60	2.4/24.0
46-328	10 mm	3/8" x 10"	10 x 250	6/48	2.6/20.8

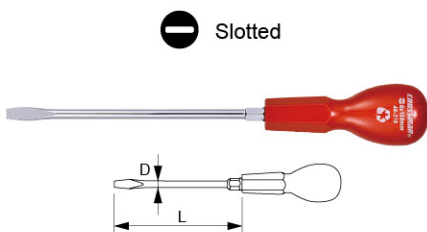

- ** Crossman platinum shaft; hardened but high ductility.
- ** Handle is made of eco-friendly acetate w/fiber.
- ** Ideal for mechanical machine, mining or engineering sites etc.

Screwdrivers

Sheffield Acetate Handle Screwdrivers - Phillips

Item No.		Size (DxL)		Pkg	kgs
		inch	mm		
46-333	PH0	1/8" x 3"	3 x 75	12/600	0.3/16.0
46-334	PH0	1/8" x 4"	3 x 100	12/600	0.4/18.0
46-420	PH0	5/32" x 3"	4 x 75	12/600	0.4/20.0
46-335	PH0	5/32" x 4"	4 x 100	12/600	0.4/20.3
46-336	PH0	5/32" x 6"	4 x 150	12/600	0.5/23.8
46-337	PH0	5/32" x 8"	4 x 200	12/600	0.6/27.4
46-338	PH0	5/32" x 12"	4 x 300	12/240	0.7/14.2
46-421	PH1	3/16" x 3"	5 x 75	12/300	0.8/21.5
46-340	PH1	3/16" x 4"	5 x 100	12/300	0.9/22.1
46-341	PH1	3/16" x 6"	5 x 150	12/300	1.0/24.3
46-342	PH1	3/16" x 8"	5 x 200	12/300	1.1/26.8
46-356	PH1	3/16" x 10"	5 x 250	12/240	1.0/20.3
46-343	PH1	3/16" x 12"	5 x 300	12/240	1.0/20.3
46-422	PH2	1/4" x 4"	6 x 100	12/120	1.3/13.2
46-423	PH2	1/4" x 6"	6 x 150	12/120	1.3/13.4
46-347	PH2	1/4" x 8"	6 x 200	12/120	1.4/13.6
46-357	PH2	1/4" x 10"	6 x 250	12/120	1.4/15.0
46-348	PH2	1/4" x 12"	6 x 300	12/120	1.6/15.6
46-424	PH3	5/16" x 6"	8 x 150	6/60	1.6/16.0
46-425	PH3	5/16" x 8"	8 x 200	6/60	1.8/18.0
46-426	PH3	5/16" x 10"	8 x 250	6/60	2.0/20.0
46-351	PH3	5/16" x 12"	8 x 300	6/60	2.1/21.0
46-427	PH4	3/8" x 8"	10 x 200	6/60	2.1/21.0
46-428	PH4	3/8" x 10"	10 x 250	6/60	2.3/23.0
46-353	PH4	3/8" x 12"	10 x 300	6/60	2.5/25.0

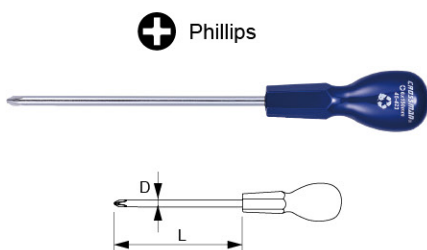

Sheffield Acetate Handle Screwdrivers - Phillips w/Hex Bolster

Item No.	Pt. Size	Size (DxL)		Pkg	kgs
		inch	mm		
46-339	PH1	3/16" x 3"	5 x 75	12/300	0.8/20.0
46-429	PH1	3/16" x 4"	5 x 100	12/300	0.9/22.1
46-345	PH2	1/4" x 4"	6 x 100	12/240	1.2/23.0
46-346	PH2	1/4" x 6"	6 x 150	12/240	1.2/24.0
46-349	PH3	5/16" x 6"	8 x 150	6/120	0.7/13.5
46-350	PH3	5/16" x 8"	8 x 200	6/120	0.7/14.5
46-352	PH4	3/8" x 8"	10 x 200	6/60	2.4/24.0
46-358	PH4	3/8" x 10"	10 x 250	6/48	2.6/20.8

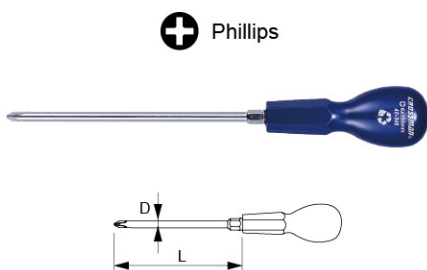

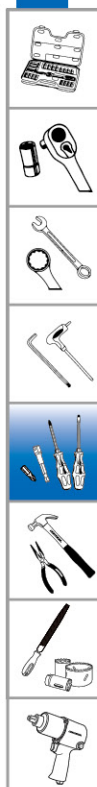

- ** Crossman platinum shaft; hardened but high ductility.
- ** Handle is made of eco-friendly acetate w/fiber.
- ** Ideal for mechanical machine, mining or engineering work etc.



Screwdrivers



■ Cushion Grip Tri-Handle Screwdrivers - Slotted

Item No.	Pt. Size	Size (DxL)			
		inch	mm		
46-051	3mm	1/8" x 3"	3 x 75	12/240	0.4/7.8
46-052	3mm	1/8" x 4"	3 x 100	12/240	0.4/8.4
46-053	3mm	1/8" x 6"	3 x 150	12/240	0.4/8.4
46-054	3mm	1/8" x 8"	3 x 200	12/120	0.4/4.5
46-055	3mm	1/8" x 10"	3 x 250	12/96	0.4/4.0
46-003	4mm	5/32" x 4"	4 x 100	12/96	0.4/4.0
46-004	4mm	5/32" x 6"	4 x 150	12/120	0.4/5.0
46-005	4mm	5/32" x 8"	4 x 200	12/120	0.5/5.0
46-838	4mm	5/32" x 12"	4 x 300	12/72	1.2/8.0
46-061	5mm	3/16" x 3"	5 x 75	12/120	1.0/10.5
46-062	5mm	3/16" x 4"	5 x 100	12/96	1.0/8.0
46-063	5mm	3/16" x 6"	5 x 150	12/96	1.0/8.0
46-064	5mm	3/16" x 8"	5 x 200	12/72	1.0/6.5
46-065	5mm	3/16" x 10"	5 x 250	12/72	1.0/7.0
46-066	5mm	3/16" x 12"	5 x 300	12/72	1.3/8.5
46-844	6mm	1/4" x 1-1/2"	6 x 38 (Stubby)	12/96	1.1/9.0
46-009	6mm	1/4" x 4"	6 x 100	12/96	1.4/11.5
46-010	6mm	1/4" x 6"	6 x 150	12/96	1.5/12.0
46-117	6mm	1/4" x 8"	6 x 200	12/72	1.6/10.5
46-848	6mm	1/4" x 12"	6 x 300	12/72	2.1/13.0
46-028	8mm	5/16" x 6"	8 x 150	12/72	2.2/13.5
46-013	8mm	5/16" x 8"	8 x 200	12/72	2.3/14.5
46-119	8mm	5/16" x 10"	8 x 250	12/72	2.6/15.6
46-141	10mm	3/8" x 8"	10 x 200	12/72	2.8/16.8
46-142	10mm	3/8" x 10"	10 x 250	12/72	2.9/17.2
46-143	10mm	3/8" x 12"	10 x 300	12/72	2.9/17.2

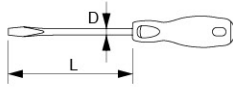
 Slotted



■ Cushion Grip Tri-Handle Screwdrivers - Slotted w/Hex Bolster

Item No.	Pt. Size	Size (DxL)			
		inch	mm		
46-101	5mm	3/16" x 3"	5 x 75	12/120	1.0/10.5
46-102	5mm	3/16" x 4"	5 x 100	12/96	0.9/10.5
46-105	6mm	1/4" x 4"	6 x 100	12/96	1.4/12.0
46-106	6mm	1/4" x 6"	6 x 150	12/72	1.5/9.5
46-110	8mm	5/16" x 6"	8 x 150	12/72	1.1/7.5
46-111	8mm	5/16" x 8"	8 x 200	12/72	1.2/7.5
46-120	10mm	3/8" x 8"	10 x 200	12/72	1.2/7.5

 Slotted

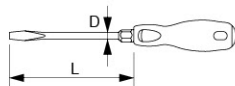

- ** Crossman platinum shaft; hardened but high ductility.
- ** Handle is made of cushion-grip material for more powerful drive.
- ** Ideal for construction or furnishing work etc.

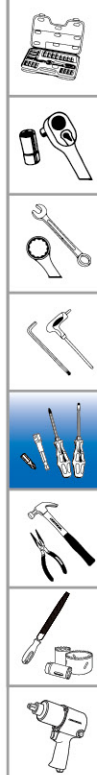

Screwdrivers

Cushion Grip Tri-Handle Screwdrivers - Phillips

Item No.	Pt. Size	Size (DxL)		Pkg	kgs
		inch	mm		
46-215	PH0	1/8" x 3"	3 x 75	12/240	0.4/7.8
46-216	PH0	1/8" x 4"	3 x 100	12/240	0.4/8.4
46-217	PH0	1/8" x 6"	3 x 150	12/240	0.4/8.4
46-219	PH0	1/8" x 10"	3 x 250	12/96	0.4/4.0
46-017	PH0	5/32" x 4"	4 x 100	12/96	0.4/4.0
46-018	PH0	5/32" x 6"	4 x 150	12/120	0.4/5.0
46-019	PH0	5/32" x 8"	4 x 200	12/120	0.5/5.0
46-868	PH0	5/32" x 12"	4 x 300	12/72	1.2/8.0
46-020	PH1	3/16" x 4"	5 x 100	12/96	0.9/8.0
46-233	PH1	3/16" x 5"	5 x 125	12/96	0.9/8.0
46-234	PH1	3/16" x 6"	5 x 150	12/96	0.9/8.0
46-235	PH1	3/16" x 8"	5 x 200	12/72	1.0/6.5
46-236	PH1	3/16" x 10"	5 x 250	12/72	1.0/7.0
46-873	PH1	3/16" x 12"	5 x 300	12/72	1.3/8.5
46-661	PH2	1/4" x 1-1/2"	6 x 38 (Stubby)	12/96	1.1/9.0
46-021	PH2	1/4" x 4"	6 x 100	12/96	1.4/11.5
46-246	PH2	1/4" x 5"	6 x 125	12/120	1.4/12.0
46-024	PH2	1/4" x 6"	6 x 150	12/96	1.5/12.0
46-025	PH2	1/4" x 8"	6 x 200	12/72	1.6/10.5
46-248	PH2	1/4" x 10"	6 x 250	12/72	2.1/13.0
46-026	PH3	5/16" x 6"	8 x 150	12/72	2.2/13.5
46-027	PH3	5/16" x 8"	8 x 200	12/72	2.3/14.5
46-881	PH3	5/16" x 10"	8 x 300	12/72	2.4/15.4
46-883	PH3	5/16" x 12"	10 x 300	12/72	2.9/17.2

⊕ Phillips

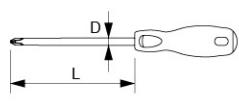

Cushion Grip Tri-Handle Screwdrivers - Phillips w/Hex Bolster

Item No.	Pt. Size	Size (DxL)		Pkg	kgs
		inch	mm		
46-121	PH1	3/16" x 3"	5 x 75	12/120	1.0/11.0
46-122	PH1	3/16" x 4"	5 x 100	12/96	1.0/8.5
46-125	PH2	1/4" x 4"	6 x 100	12/96	1.4/12.0
46-126	PH2	1/4" x 6"	6 x 150	12/72	1.5/9.5
46-130	PH3	5/16" x 6"	8 x 150	12/72	2.2/14.2
46-131	PH3	5/16" x 8"	8 x 200	12/72	2.3/14.6
46-882	PH4	3/8" x 8"	10 x 200	12/72	2.8/16.8

⊕ Phillips

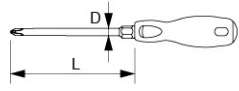

** Crossman platinum shaft; hardened but high ductility.
 ** Handle is made of cushion-grip material for more powerful drive.
 ** Ideal for construction or furnishing work etc.

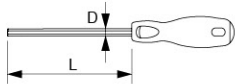
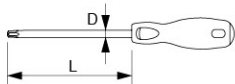
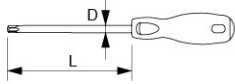

Screwdrivers

Cushion Grip Tri-Handle Screwdrivers - TORX®

Item No.	Pt. Size	Size (DxL)		Pkg	kgs
		inch	mm		
46-686	T10	3/16" x 4"	5 x 100	12/96	0.4/3.5
46-687	T15	3/16" x 4"	5 x 100	12/96	0.4/3.5
46-688	T20	3/16" x 4"	5 x 100	12/96	0.4/3.5
46-689	T25	1/4" x 4"	6 x 100	12/96	1.2/10.5
46-690	T30	1/4" x 4"	6 x 100	12/96	1.2/10.5

Cushion Grip Tri-Handle Screwdrivers - TORX® Tamper Proof

Item No.	Pt. Size	Size (DxL)		Pkg	kgs
		inch	mm		
46-360	T6	5/32" x 3"	4 x 75	12/240	0.3/7.5
46-361	T7	5/32" x 3"	4 x 75	12/240	0.3/7.5
46-362	T8	5/32" x 3"	4 x 75	12/120	0.4/4.0
46-363	T9	5/32" x 3"	4 x 75	12/120	0.4/4.0
46-364	T10	3/16" x 4"	5 x 100	12/96	0.9/8.0
46-365	T15	3/16" x 4"	5 x 100	12/96	0.9/8.0
46-366	T20	3/16" x 4"	5 x 100	12/96	0.9/8.0
46-367	T25	1/4" x 4"	6 x 100	12/96	1.2/10.0
46-368	T27	1/4" x 4"	6 x 100	12/96	1.2/10.0
46-369	T30	1/4" x 4"	6 x 100	12/96	1.2/10.0
46-370	T40	1/4" x 4"	6 x 100	12/96	1.3/10.5

Cushion Grip Tri-Handle Screwdrivers - Hex

Item No.	Pt. Size	Size (DxL)		Pkg	kgs
		inch	mm		
46-891	H2	5/64" x 3"	2.0 x 75	12/120	0.3/4.0
46-892	H2.5	3/32" x 3"	2.5 x 75	12/120	0.3/4.0
46-893	H3	1/8" x 4"	3.0 x 100	12/120	0.4/4.2
46-894	H4	5/32" x 4"	4.0 x 100	12/96	1.0/8.2
46-895	H5	3/16" x 4"	5.0 x 100	12/96	1.0/9.0
46-896	H6	1/4" x 5"	6.0 x 125	12/96	1.1/9.0

- ** Crossman platinum shaft; hardened but high ductility.
- ** Handle is made of cushion-grip material for more powerful drive.
- ** Ideal for construction or furnishing work etc.

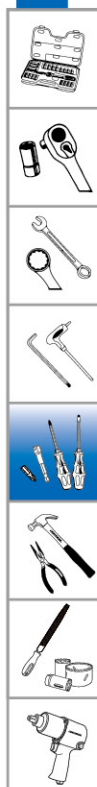

Screwdrivers

Electronic Slotted Screwdrivers

Item No.	Size		 kgs
46-608	1.0mm x 50mm	12/240	0.25/5
46-609	1.2mm x 50mm	12/240	0.25/5
46-610	1.5mm x 50mm	12/240	0.25/5
46-611	2.0mm x 50mm	12/240	0.25/5
46-612	2.5mm x 50mm	12/240	0.25/5
46-613	3.0mm x 50mm	12/240	0.25/5
46-614	4.0mm x 50mm	12/240	0.25/5

 Slotted



Electronic Phillips Screwdriver

Item No.	Size		 kgs
46-615	1.5mm #000 x 50mm	12/240	0.25/5
46-616	2mm #00 x 50mm	12/240	0.25/5
46-617	2.5mm #0 x 50mm	12/240	0.25/5
46-618	4mm #1 x 50mm	12/240	0.25/5

 Phillips



LR Precision Screwdriver-Ideal for Cell Phone Repairing

Item No.	Size		 kgs
46-621	2.5mm x 50mm	12/240	0.25/5

 LR Precision



TRI-WING[®] Screwdriver

Item No.	Size		 kgs
46-622	3.0mm x 50mm	12/240	0.25/5
46-401	3.5mm x 50mm	12/240	0.25/5

 TRI-WING[®]



Triangle Screwdriver

Item No.	Size		 kgs
46-402	2.5mm x 50mm	12/240	0.25/5

 Triangle



Spanner Screwdriver

Item No.	Size		 kgs
46-600	5mm x 100mm	12/96	1.1/9.6

 Spanner



Magnetic Bit Holder

Item No.	Size		 kgs
46-604	4"	12/120	1.2/13.0



Magnetizer

Item No.		 kgs
44-100	25/100	1.2/4.7

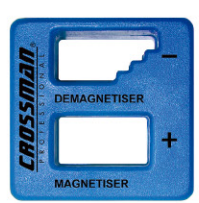

Screwdrivers

⊕ Phillips

⊖ Slotted



■ 2-Way Screwdriver Set

Item No.	Size		 kgs
46-500	6mm x 38mm	5/100	0.8/16
46-501	6mm x 100mm	5/50	0.7/7
46-502	6mm x 150mm	5/50	0.75/7.5
46-503	6mm x 200mm	5/50	0.8/8
46-504	4mm x 100mm	5/50	0.65/6.5
46-505	4mm x 150mm	5/50	0.7/7
46-506	4mm x 200mm	5/50	0.75/7.5

■ 2-Way Stubby Screwdriver Set



Item No.	Size		 kgs
46-100	⊕ No.2 x ⊖ 6mm 6.35mm x 36mm L (1.4" L)	12/120	1.0/20.0

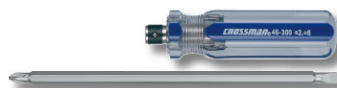

■ 2-Way Screwdriver Set

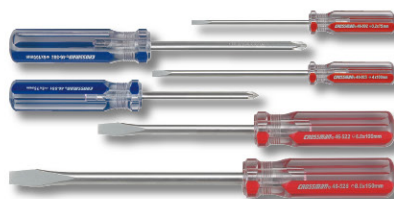

Item No.	Size		 kgs
46-200	⊕ No.2 x ⊖ 6mm 6.35mm x 100mm L (4" L)	12/120	1.6/17.0
46-300	⊕ No.2 x ⊖ 6mm 6.35mm x 150mm L (6" L)	12/120	1.8/18.0
46-400	⊕ No.2 x ⊖ 6mm 6.35mm x 200mm L (8" L)	12/120	1.8/19.0

■ Line Color Acetate Handle Screwdriver Set - 6 Pcs.



Item No.		 kgs
46-903	6/24	1.5/6.5

⊖ Slotted:

3mm x 75mm L, 4mm x 100mm L, 6mm x 100mm L, 8mm x 150mm L.

⊕ Phillips:

5mm x 75mm L, 6mm x 100mm L.

Screwdrivers



■ Cushion Grip Tri-Handle Screwdriver Set w/Hex Bolster - 4 Pcs.

Item No.	 	 kgs
46-904	6/24	2.7/11.0

- ⊖ Slotted:
5mm x 75mm L, 6mm x 150mm L.
- ⊕ Phillips:
5mm x 75mm L, 6mm x 100mm L.



■ Cushion Grip Tri-Handle Screwdriver Set w/Hex Bolster - 6 Pcs.

Item No.	 	 kgs
46-906	6/24	1.1/27.5

- ⊖ Slotted:
5mm x 75mm L, 5mm x 125mm L, 6mm x 100mm L, 6mm x 150mm L.
- ⊕ Phillips:
5mm x 75mm L, 6mm x 100mm L.



■ Cushion Grip Tri-Handle Screwdriver Set w/Hex Bolster - 8 Pcs.

Item No.	 	 kgs
46-901	1/6	1.3/8.5

- ⊖ Slotted:
6mm x 100mm L, 6mm x 150mm L, 8mm x 150mm L, 8mm x 200mm L.
- ⊕ Phillips:
6mm x 100mm L, 6mm x 150mm L, 8mm x 150mm L, 8mm x 200mm L.



■ Cushion Grip Tri-Handle Screwdriver Set - 8 Pcs.

Item No.	 	 kgs
46-900	1/6	1.2/8.0

- ⊖ Slotted:
3mm x 75mm L, 5mm x 100mm L, 6mm x 150mm L, 8mm x 150mm L.
- ⊕ Phillips:
3mm x 75mm L, 5mm x 100mm L, 6mm x 150mm L, 8mm x 150mm L.

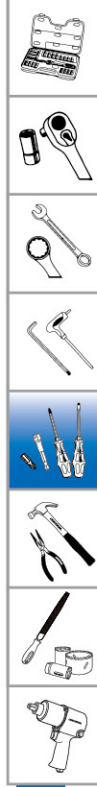

Screwdrivers



Electronic Screwdriver Set - 6 Pcs.

Item No.		 kgs
46-933	6/48	1.03/8.2

- ⊕ Phillips: #00, #0
- ⊖ Slotted: 1.5mm, 3mm, 2mm, 2.5mm



Electronic TORX[®] Tamper Proof Screwdriver Set - 6 Pcs.

Item No.		 kgs
46-934	6/48	1.03/8.2

- ⊕ TORX[®] Tamper Proof : T5, T6, T7, T8, T9, T10



Electronic Hex Screwdriver Set - 6 Pcs.

Item No.		 kgs
46-935	6/48	1.03/8.2

- Hex: 0.9mm, 1.3mm, 1.5mm, 2mm, 2.5mm, 3mm



14 in 1 Electronic Screwdriver Set - 7 Pcs.

Item No.		 kgs
46-936	6/24	2.25/9

- ⊕ Phillips: #000, #00, #0, #1
- ⊖ Slotted: 1.5mm, 2mm, 2.5mm, 3mm
- ⊕ TORX[®] : T5
- ⊕ TORX[®] Tamper Proof: T6, T7, T8, T10, T15



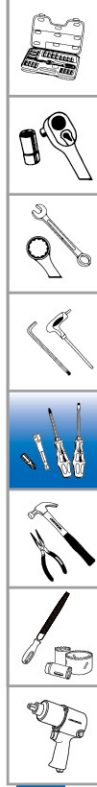

Fastener Drive Tool

Magnetic Power Nutsetters Bits (SAE) - 1/4" Hex x 45mm L

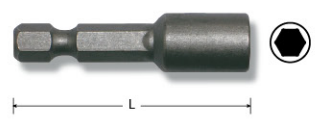

Item No.	Hex Drive	Shank Dia.	Overall Length			kgs
48-502	1/4"	6.35mm(1/4")	45mm L	50/500		0.9/9.0
48-504	5/16"	6.35mm(1/4")	45mm L	50/500		1.0/10.0
48-506	3/8"	6.35mm(1/4")	45mm L	50/500		1.2/12.0
48-507	7/16"	6.35mm(1/4")	45mm L	50/500		1.5/12.0
48-509	1/2"	6.35mm(1/4")	45mm L	50/500		1.5/16.0
48-510	9/16"	6.35mm(1/4")	45mm L	50/500		1.5/25.0

Magnetic Power Nutsetters Bits (SAE) - 1/4" Hex x 65mm L

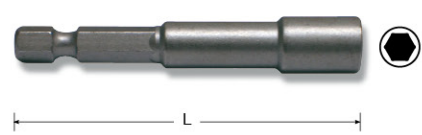

Item No.	Hex Drive	Shank Dia.	Overall Length			kgs
48-522	1/4"	6.35mm(1/4")	65mm L	50/500		1.2/13.0
48-524	5/16"	6.35mm(1/4")	65mm L	50/500		1.3/14.0
48-526	3/8"	6.35mm(1/4")	65mm L	50/500		1.7/18.0
48-527	7/16"	6.35mm(1/4")	65mm L	50/500		2.3/21.8
48-529	1/2"	6.35mm(1/4")	65mm L	50/500		2.5/24.0
48-530	9/16"	6.35mm(1/4")	65mm L	50/500		2.8/26.0

Magnetic Power Nutsetters Bits (Metric) - 1/4" Hex x 45mm L

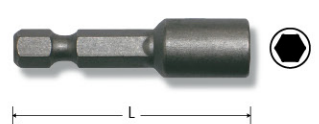

Item No.	Hex Drive	Shank Dia.	Overall Length			kgs
48-541	5.5mm	6.35mm(1/4")	45mm L	50/1000		0.9/18.0
48-542	6mm	6.35mm(1/4")	45mm L	50/1000		0.9/19.0
48-543	7mm	6.35mm(1/4")	45mm L	50/1000		0.9/19.0
48-544	8mm	6.35mm(1/4")	45mm L	50/1000		1.0/20.0
48-545	9mm	6.35mm(1/4")	45mm L	50/1000		1.0/22.0
48-546	10mm	6.35mm(1/4")	45mm L	50/1000		1.2/24.0
48-547	11mm	6.35mm(1/4")	45mm L	50/800		1.5/24.0
48-548	12mm	6.35mm(1/4")	45mm L	50/800		1.5/24.0
48-549	13mm	6.35mm(1/4")	45mm L	50/500		1.5/16.0
48-550	14mm	6.35mm(1/4")	45mm L	50/500		2.5/25.0



Magnetic Power Nutsetters Bits (Metric) - 1/4" Hex x 65mm L



Item No.	Hex Drive	Shank Dia.	Overall Length			kgs
48-561	5.5mm	6.35mm(1/4")	65mm L	50/1000		1.1/23.0
48-562	6mm	6.35mm(1/4")	65mm L	50/1000		1.1/23.0
48-563	7mm	6.35mm(1/4")	65mm L	50/1000		1.1/23.0
48-564	8mm	6.35mm(1/4")	65mm L	50/800		1.3/21.0
48-565	9mm	6.35mm(1/4")	65mm L	50/600		1.6/20.0
48-566	10mm	6.35mm(1/4")	65mm L	50/600		1.6/20.0
48-567	11mm	6.35mm(1/4")	65mm L	50/500		2.3/23.0
48-568	12mm	6.35mm(1/4")	65mm L	50/500		2.3/23.0
48-569	13mm	6.35mm(1/4")	65mm L	50/500		2.5/25.0
48-570	14mm	6.35mm(1/4")	65mm L	50/400		2.8/22.6



Fastener Drive Tool

■ **Ball-Lock Socket Adapters (SAE) - 1/4" Hex**

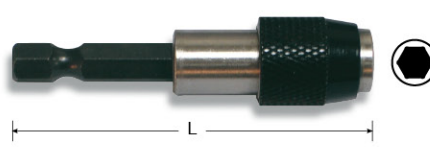
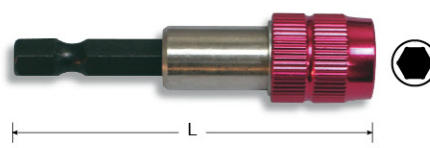
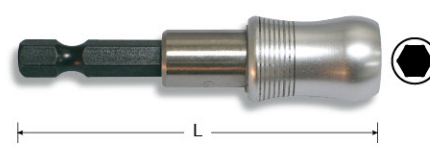

Item No.	Square Drive	Shank Dia.	Overall Length		 kgs
48-581	1/4"	6.35mm(1/4")	25mm L	50/2000	0.5/20.0
48-582	1/4"	6.35mm(1/4")	50mm L	50/1000	0.8/17.0
48-583	1/4"	6.35mm(1/4")	65mm L	50/1000	1.0/21.0
48-585	3/8"	6.35mm(1/4")	50mm L	50/500	1.4/15.0
48-586	3/8"	6.35mm(1/4")	65mm L	50/500	1.6/16.8
48-588	1/2"	6.35mm(1/4")	72mm L	25/375	1.0/15.0





■ **Magnetic Float Adapters (SAE) - 1/4" Hex**

Item No.	Chuck Capacity	Overall Length		 kgs
48-912	1/4"	65mm L	25/750	1.0/21.4
48-913	1/4"	75mm L	25/500	1.2/24.0

■ **Pull-Lock Adapters (SAE) - 1/4" Hex**

Item No.	Chuck Capacity	Overall Length		 kgs
48-921	1/4"	60mm L	25/750	0.7/20.0
48-922	1/4"	65mm L	25/750	0.9/21.4
48-923	1/4"	75mm L	25/500	1.1/24.0

■ **Push-Lock Adapters (SAE) - 1/4" Hex**

Item No.	Chuck Capacity	Overall Length		 kgs
48-931	1/4"	60mm L	25/750	0.7/20.0
48-932	1/4"	65mm L	25/750	0.9/21.4
48-933	1/4"	75mm L	25/500	1.1/24.0



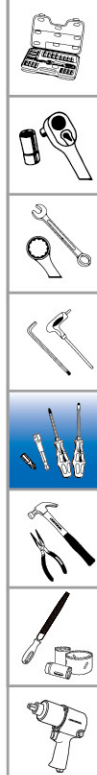

Fastener Drive Tool

■ **One-Piece Stainless Steel Magnetic Bit Holder (SAE) - 1/4" Hex**

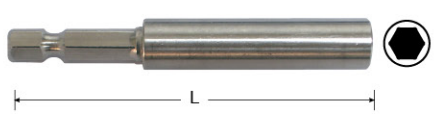

Item No.	Bit Drive	Overall Length			kgs
48-941	1/4"	60mm L	25/750		0.6/21.4
48-942	1/4"	75mm L	25/500		0.8/17.0
48-943	1/4"	100mm L	25/500		1.0/21.0
48-944	1/4"	150mm L	25/300		2.4/24.0

■ **One-Piece Stainless Steel Magnetic Bit Holder (w/Ring) - 1/4" Hex**



Item No.	Bit Drive	Overall Length			kgs
48-951	1/4"	60mm L	25/500		0.6/12.0
48-952	1/4"	75mm L	25/300		0.8/11.0

■ **Magnetic Screw Guide - 1/4" Hex**



Item No.	Bit Drive	Overall Length			kgs
48-971	1/4"	80mm L	25/500		0.7/14.0
48-972	1/4"	120mm L	25/300		1.1/14.2

■ **Magnetic Bit Holder (Stainless Steel Housing) - 1/4" Hex**

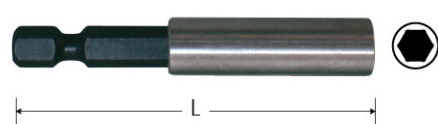

Item No.	Bit Drive	Overall Length			kgs
48-961	1/4"	60mm L	25/500		1.2/16.0
48-962	1/4"	75mm L	25/500		0.8/17.0
48-963	1/4"	100mm L	25/500		1.0/21.0
48-964	1/4"	150mm L	25/300		1.3/15.6
48-965	1/4"	175mm L	25/250		1.6/17.0
48-966	1/4"	200mm L	25/250		1.8/19.0

■ **Knurled Shank Magnetic Bit Holder (Stainless Steel Housing) - 1/4" Hex**



Item No.	Bit Drive	Overall Length			kgs
48-968	1/4"	63mm L	25/500		1.2/16.0

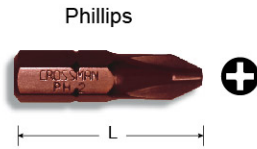

Phillips

Insert Bits

■ Phillips Insert Bits - 1/4" Hex x 25mm L

Item No.	Pt. Size	Shank Dia.	Overall Length		 kgs
44-200	PH0	6.35mm(1/4")	25mm L	100/1000	0.7/8.0
44-201	PH1	6.35mm(1/4")	25mm L	100/1000	0.7/8.0
44-202	PH2	6.35mm(1/4")	25mm L	100/1000	0.7/8.0
44-203	PH3	6.35mm(1/4")	25mm L	100/1000	0.7/8.0
44-204	PH4	6.35mm(1/4")	25mm L	100/1000	0.7/8.0

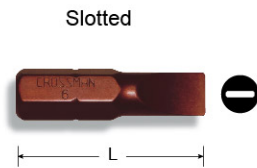

Slotted

■ Slotted Insert Bits (Metric) - 1/4" Hex x 25mm L

Item No.	Pt. Size	Shank Dia.	Overall Length		 kgs
44-213	3mm	6.35mm(1/4")	25mm L	100/1000	0.7/8.0
44-214	4mm	6.35mm(1/4")	25mm L	100/1000	0.7/8.0
44-215	4.5mm	6.35mm(1/4")	25mm L	100/1000	0.7/8.0
44-216	5mm	6.35mm(1/4")	25mm L	100/1000	0.7/8.0
44-217	5.5mm	6.35mm(1/4")	25mm L	100/1000	0.7/8.0
44-218	6mm	6.35mm(1/4")	25mm L	100/1000	0.7/8.0
44-219	6.5mm	6.35mm(1/4")	25mm L	100/1000	0.7/8.0
44-220	7mm	6.35mm(1/4")	25mm L	100/1000	0.8/9.0
44-221	8mm	6.35mm(1/4")	25mm L	100/1000	0.9/10.0
44-222	10mm	6.35mm(1/4")	25mm L	100/1000	1.1/12.0



Hex

■ Hex Insert Bits (SAE) - 1/4" Hex x 25mm L

Item No.	Pt. Size	Shank Dia.	Overall Length		 kgs
44-231	1/16"	6.35mm(1/4")	25mm L	100/1000	0.7/8.0
44-232	5/64"	6.35mm(1/4")	25mm L	100/1000	0.7/8.0
44-233	3/32"	6.35mm(1/4")	25mm L	100/1000	0.7/8.0
44-234	7/64"	6.35mm(1/4")	25mm L	100/1000	0.7/8.0
44-235	1/8"	6.35mm(1/4")	25mm L	100/1000	0.7/8.0
44-236	9/64"	6.35mm(1/4")	25mm L	100/1000	0.7/8.0
44-237	5/32"	6.35mm(1/4")	25mm L	100/1000	0.8/9.0
44-238	3/16"	6.35mm(1/4")	25mm L	100/1000	0.8/9.0
44-239	7/32"	6.35mm(1/4")	25mm L	100/1000	0.8/9.0
44-240	1/4"	6.35mm(1/4")	25mm L	100/1000	0.8/9.0
44-242	5/16"	6.35mm(1/4")	25mm L	100/1000	0.8/9.0
44-243	3/8"	6.35mm(1/4")	25mm L	100/1000	1.4/15.0



Insert Bits

Hex Insert Bits (Metric) - 1/4" Hex x 25mm L

Item No.	Pt. Size	Shank Dia.	Overall Length		 kgs
44-245	1.5mm	6.35mm(1/4")	25mm L	100/1000	0.7/8.0
44-246	2mm	6.35mm(1/4")	25mm L	100/1000	0.7/8.0
44-247	2.5mm	6.35mm(1/4")	25mm L	100/1000	0.7/8.0
44-248	3mm	6.35mm(1/4")	25mm L	100/1000	0.7/8.0
44-249	4mm	6.35mm(1/4")	25mm L	100/1000	0.7/8.0
44-250	5mm	6.35mm(1/4")	25mm L	100/1000	0.8/9.0
44-251	5.5mm	6.35mm(1/4")	25mm L	100/1000	0.8/9.0
44-252	6mm	6.35mm(1/4")	25mm L	100/1000	0.8/9.0
44-253	7mm	6.35mm(1/4")	25mm L	100/1000	0.8/9.0
44-254	8mm	6.35mm(1/4")	25mm L	100/1000	0.8/9.0
44-255	10mm	6.35mm(1/4")	25mm L	100/1000	1.4/15.0



Hex Tamper Proof Insert Bits (SAE) - 1/4" Hex x 25mm L

Item No.	Pt. Size	Shank Dia.	Overall Length		 kgs
44-271	1/16"	6.35mm(1/4")	25mm L	100/1000	0.7/8.0
44-272	5/64"	6.35mm(1/4")	25mm L	100/1000	0.7/8.0
44-273	3/32"	6.35mm(1/4")	25mm L	100/1000	0.7/8.0
44-274	7/64"	6.35mm(1/4")	25mm L	100/1000	0.7/8.0
44-275	1/8"	6.35mm(1/4")	25mm L	100/1000	0.7/8.0
44-276	9/64"	6.35mm(1/4")	25mm L	100/1000	0.7/8.0
44-277	5/32"	6.35mm(1/4")	25mm L	100/1000	0.8/9.0
44-278	3/16"	6.35mm(1/4")	25mm L	100/1000	0.8/9.0
44-279	7/32"	6.35mm(1/4")	25mm L	100/1000	0.8/9.0
44-280	1/4"	6.35mm(1/4")	25mm L	100/1000	0.8/9.0
44-281	5/16"	6.35mm(1/4")	25mm L	100/1000	0.8/9.0
44-282	3/8"	6.35mm(1/4")	25mm L	100/1000	1.4/15.0



Hex Tamper Proof Insert Bits (Metric) - 1/4" Hex x 25mm L

Item No.	Pt. Size	Shank Dia.	Overall Length		 kgs
44-285	1.5mm	6.35mm(1/4")	25mm L	100/1000	0.7/8.0
44-286	2mm	6.35mm(1/4")	25mm L	100/1000	0.7/8.0
44-287	2.5mm	6.35mm(1/4")	25mm L	100/1000	0.7/8.0
44-288	3mm	6.35mm(1/4")	25mm L	100/1000	0.7/8.0
44-289	4mm	6.35mm(1/4")	25mm L	100/1000	0.7/8.0
44-290	5mm	6.35mm(1/4")	25mm L	100/1000	0.8/9.0
44-291	5.5mm	6.35mm(1/4")	25mm L	100/1000	0.8/9.0
44-292	6mm	6.35mm(1/4")	25mm L	100/1000	0.8/9.0
44-293	7mm	6.35mm(1/4")	25mm L	100/1000	0.8/9.0
44-294	8mm	6.35mm(1/4")	25mm L	100/1000	0.8/9.0
44-295	10mm	6.35mm(1/4")	25mm L	100/1000	1.4/15.0

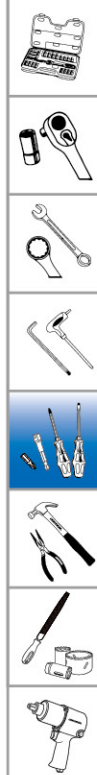

Insert Bits

■ TORX[®] Insert Bits - 1/4" Hex x 25mm L

Item No.	Pt. Size	Shank Dia.	Overall Length		 kgs
44-301	T-5	6.35mm(1/4")	25mm L	100/1000	0.4/5.0
44-302	T-6	6.35mm(1/4")	25mm L	100/1000	0.4/5.0
44-303	T-7	6.35mm(1/4")	25mm L	100/1000	0.4/5.0
44-304	T-8	6.35mm(1/4")	25mm L	100/1000	0.4/5.0
44-305	T-9	6.35mm(1/4")	25mm L	100/1000	0.4/5.0
44-306	T-10	6.35mm(1/4")	25mm L	100/1000	0.4/5.0
44-307	T-15	6.35mm(1/4")	25mm L	100/1000	0.4/5.0
44-308	T-20	6.35mm(1/4")	25mm L	100/1000	0.5/6.0
44-309	T-25	6.35mm(1/4")	25mm L	100/1000	0.5/6.0
44-310	T-27	6.35mm(1/4")	25mm L	100/1000	0.5/6.0
44-311	T-30	6.35mm(1/4")	25mm L	100/1000	0.5/6.0
44-312	T-35	6.35mm(1/4")	25mm L	100/1000	0.6/7.0
44-313	T-40	6.35mm(1/4")	25mm L	100/1000	0.6/7.0
44-314	T-45	6.35mm(1/4")	25mm L	100/1000	0.7/8.0
44-315	T-50	6.35mm(1/4")	25mm L	100/1000	0.8/9.0



■ TORX[®] Tamper Proof Insert Bits - 1/4" Hex x 25mm L

Item No.	Pt. Size	Shank Dia.	Overall Length		 kgs
44-321	T-5	6.35mm(1/4")	25mm L	100/1000	0.4/5.0
44-322	T-6	6.35mm(1/4")	25mm L	100/1000	0.4/5.0
44-323	T-7	6.35mm(1/4")	25mm L	100/1000	0.4/5.0
44-324	T-8	6.35mm(1/4")	25mm L	100/1000	0.4/5.0
44-325	T-9	6.35mm(1/4")	25mm L	100/1000	0.4/5.0
44-326	T-10	6.35mm(1/4")	25mm L	100/1000	0.4/5.0
44-327	T-15	6.35mm(1/4")	25mm L	100/1000	0.4/5.0
44-328	T-20	6.35mm(1/4")	25mm L	100/1000	0.5/6.0
44-329	T-25	6.35mm(1/4")	25mm L	100/1000	0.5/6.0
44-330	T-27	6.35mm(1/4")	25mm L	100/1000	0.5/6.0
44-331	T-30	6.35mm(1/4")	25mm L	100/1000	0.5/6.0
44-332	T-35	6.35mm(1/4")	25mm L	100/1000	0.6/7.0
44-333	T-40	6.35mm(1/4")	25mm L	100/1000	0.6/7.0
44-334	T-45	6.35mm(1/4")	25mm L	100/1000	0.7/8.0
44-335	T-50	6.35mm(1/4")	25mm L	100/1000	0.8/9.0



■ POZIDRIV[®] Insert Bits - 1/4" Hex x 25mm L

Item No.	Pt. Size	Shank Dia.	Overall Length		 kgs
44-340	PZ0	6.35mm(1/4")	25mm L	100/1000	0.7/8.0
44-341	PZ1	6.35mm(1/4")	25mm L	100/1000	0.7/8.0
44-342	PZ2	6.35mm(1/4")	25mm L	100/1000	0.7/8.0
44-343	PZ3	6.35mm(1/4")	25mm L	100/1000	0.7/8.0
44-344	PZ4	6.35mm(1/4")	25mm L	100/1000	0.8/9.0

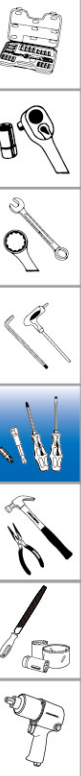

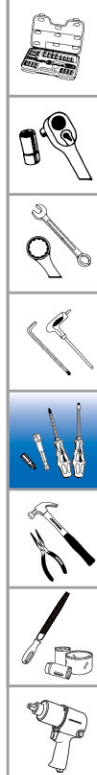

Insert Bits

TORQ-SET[®] Insert Bits - 1/4" Hex x 25mm L



Item No.	Pt. Size	Shank Dia.	Overall Length			kgs
44-351	TS-6	6.35mm(1/4")	25mm L	100/1000		0.7/8.0
44-352	TS-8	6.35mm(1/4")	25mm L	100/1000		0.7/8.0
44-353	TS-10	6.35mm(1/4")	25mm L	100/1000		0.8/9.0

Spanner Insert Bits - 1/4" Hex x 25mm L

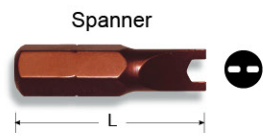

Item No.	Pt. Size	Shank Dia.	Overall Length			kgs
44-355	SP-4	6.35mm(1/4")	25mm L	100/1000		0.7/8.0
44-356	SP-6	6.35mm(1/4")	25mm L	100/1000		0.7/8.0
44-357	SP-8	6.35mm(1/4")	25mm L	100/1000		0.7/8.0
44-358	SP-10	6.35mm(1/4")	25mm L	100/1000		0.7/8.0

TRI-WING[®] Insert Bits - 1/4" Hex x 25mm L



Item No.	Pt. Size	Shank Dia.	Overall Length			kgs
44-361	TW-1	6.35mm(1/4")	25mm L	100/1000		0.7/8.0
44-362	TW-2	6.35mm(1/4")	25mm L	100/1000		0.7/8.0
44-363	TW-3	6.35mm(1/4")	25mm L	100/1000		0.7/8.0
44-364	TW-4	6.35mm(1/4")	25mm L	100/1000		0.7/8.0

Square Recess Insert Bits - 1/4" Hex x 25mm L



Item No.	Pt. Size	Shank Dia.	Overall Length			kgs
44-370	S0	6.35mm(1/4")	25mm L	100/1000		0.7/8.0
44-371	S1	6.35mm(1/4")	25mm L	100/1000		0.7/8.0
44-372	S2	6.35mm(1/4")	25mm L	100/1000		0.7/8.0
44-373	S3	6.35mm(1/4")	25mm L	100/1000		0.7/8.0

Clutch C Insert Bits (SAE) - 1/4" Hex x 25mm L

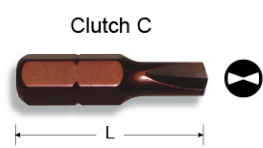

Item No.	Pt. Size	Shank Dia.	Overall Length			kgs
44-381	C1(1/8")	6.35mm(1/4")	25mm L	100/1000		0.7/8.0
44-382	C2(5/32")	6.35mm(1/4")	25mm L	100/1000		0.7/8.0
44-383	C3(3/16")	6.35mm(1/4")	25mm L	100/1000		0.7/8.0

Spline Insert Bits - 1/4" Hex x 25mm L

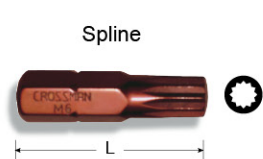

Item No.	Pt. Size	Shank Dia.	Overall Length			kgs
44-385	M5	6.35mm(1/4")	25mm L	100/1000		0.7/8.0
44-386	M6	6.35mm(1/4")	25mm L	100/1000		0.7/8.0
44-387	M8	6.35mm(1/4")	25mm L	100/1000		0.8/9.0

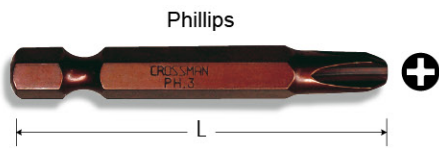

Power Bits

■ Phillips Power Bits - 1/4" Hex x 50mm L

Item No.	Pt. Size	Shank Dia.	Overall Length			kgs
44-400	PH0	6.35mm(1/4")	50mm L	100/1000		1.5/16.0
44-401	PH1	6.35mm(1/4")	50mm L	100/1000		1.5/16.0
44-402	PH2	6.35mm(1/4")	50mm L	100/1000		1.5/16.0
44-403	PH3	6.35mm(1/4")	50mm L	100/1000		1.6/17.0
44-404	PH4	6.35mm(1/4")	50mm L	100/1000		1.7/18.0

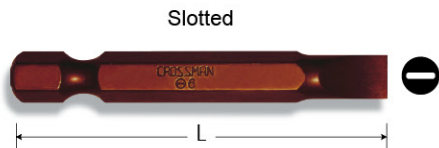

■ Slotted Power Bits (Metric) - 1/4" Hex x 50mm L

Item No.	Pt. Size	Shank Dia.	Overall Length			kgs
44-413	3mm	6.35mm(1/4")	50mm L	100/1000		1.4/15.0
44-414	4mm	6.35mm(1/4")	50mm L	100/1000		1.4/15.0
44-415	4.5mm	6.35mm(1/4")	50mm L	100/1000		1.4/15.0
44-416	5mm	6.35mm(1/4")	50mm L	100/1000		1.4/15.0
44-417	5.5mm	6.35mm(1/4")	50mm L	100/1000		1.4/15.0
44-418	6mm	6.35mm(1/4")	50mm L	100/1000		1.4/15.0
44-419	6.5mm	6.35mm(1/4")	50mm L	100/1000		1.5/16.0
44-420	7mm	6.35mm(1/4")	50mm L	100/1000		1.5/16.0
44-421	8mm	6.35mm(1/4")	50mm L	100/1000		1.6/17.0
44-422	10mm	6.35mm(1/4")	50mm L	100/1000		2.3/24.0



■ Hex Power Bits (SAE) - 1/4" Hex x 50mm L

Item No.	Pt. Size	Shank Dia.	Overall Length			kgs
44-431	1/16"	6.35mm(1/4")	50mm L	100/1000		1.4/15.0
44-432	5/64"	6.35mm(1/4")	50mm L	100/1000		1.4/15.0
44-433	3/32"	6.35mm(1/4")	50mm L	100/1000		1.4/15.0
44-434	7/64"	6.35mm(1/4")	50mm L	100/1000		1.4/15.0
44-435	1/8"	6.35mm(1/4")	50mm L	100/1000		1.4/15.0
44-436	9/64"	6.35mm(1/4")	50mm L	100/1000		1.4/15.0
44-437	5/32"	6.35mm(1/4")	50mm L	100/1000		1.4/15.0
44-438	3/16"	6.35mm(1/4")	50mm L	100/1000		1.4/15.0
44-439	7/32"	6.35mm(1/4")	50mm L	100/1000		1.4/15.0
44-440	1/4"	6.35mm(1/4")	50mm L	100/1000		1.5/16.0
44-441	9/32"	6.35mm(1/4")	50mm L	100/1000		1.5/16.0
44-442	5/16"	6.35mm(1/4")	50mm L	100/1000		1.6/17.0
44-443	3/8"	6.35mm(1/4")	50mm L	100/1000		2.4/25.0

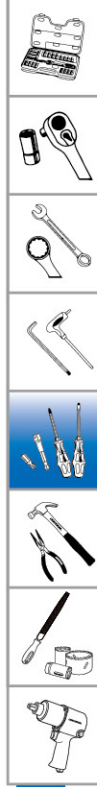

Power Bits

Hex Power Bits (Metric) - 1/4" Hex x 50mm L

Item No.	Pt. Size	Shank Dia.	Overall Length			kg
44-445	1.5mm	6.35mm(1/4")	50mm L	100/1000		1.4/15.0
44-446	2mm	6.35mm(1/4")	50mm L	100/1000		1.4/15.0
44-447	2.5mm	6.35mm(1/4")	50mm L	100/1000		1.4/15.0
44-448	3mm	6.35mm(1/4")	50mm L	100/1000		1.4/15.0
44-449	4mm	6.35mm(1/4")	50mm L	100/1000		1.4/15.0
44-450	5mm	6.35mm(1/4")	50mm L	100/1000		1.4/15.0
44-451	5.5mm	6.35mm(1/4")	50mm L	100/1000		1.4/15.0
44-452	6mm	6.35mm(1/4")	50mm L	100/1000		1.4/15.0
44-453	7mm	6.35mm(1/4")	50mm L	100/1000		1.5/16.0
44-454	8mm	6.35mm(1/4")	50mm L	100/1000		1.6/17.0
44-455	10mm	6.35mm(1/4")	50mm L	100/1000		2.4/25.0

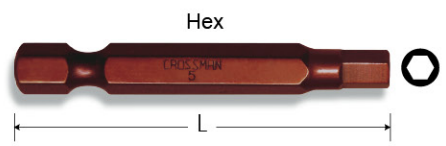

Hex Tamper Proof Power Bits (SAE) - 1/4" Hex x 50mm L

Item No.	Pt. Size	Shank Dia.	Overall Length			kg
44-471	1/16"	6.35mm(1/4")	50mm L	100/1000		1.4/15.0
44-472	5/64"	6.35mm(1/4")	50mm L	100/1000		1.4/15.0
44-473	3/32"	6.35mm(1/4")	50mm L	100/1000		1.4/15.0
44-474	7/64"	6.35mm(1/4")	50mm L	100/1000		1.4/15.0
44-475	1/8"	6.35mm(1/4")	50mm L	100/1000		1.4/15.0
44-476	9/64"	6.35mm(1/4")	50mm L	100/1000		1.4/15.0
44-477	5/32"	6.35mm(1/4")	50mm L	100/1000		1.4/15.0
44-478	3/16"	6.35mm(1/4")	50mm L	100/1000		1.4/15.0
44-479	7/32"	6.35mm(1/4")	50mm L	100/1000		1.4/15.0
44-480	1/4"	6.35mm(1/4")	50mm L	100/1000		1.4/15.0
44-481	9/32"	6.35mm(1/4")	50mm L	100/1000		1.5/16.0
44-482	5/16"	6.35mm(1/4")	50mm L	100/1000		1.6/17.0
44-483	3/8"	6.35mm(1/4")	50mm L	100/1000		2.4/25.0



Hex Tamper Proof Power Bits (Metric) - 1/4" Hex x 50mm L

Item No.	Pt. Size	Shank Dia.	Overall Length			kg
44-485	1.5mm	6.35mm(1/4")	50mm L	100/1000		1.4/15.0
44-486	2mm	6.35mm(1/4")	50mm L	100/1000		1.4/15.0
44-487	2.5mm	6.35mm(1/4")	50mm L	100/1000		1.4/15.0
44-488	3mm	6.35mm(1/4")	50mm L	100/1000		1.4/15.0
44-489	4mm	6.35mm(1/4")	50mm L	100/1000		1.4/15.0
44-490	5mm	6.35mm(1/4")	50mm L	100/1000		1.4/15.0
44-491	5.5mm	6.35mm(1/4")	50mm L	100/1000		1.4/15.0
44-492	6mm	6.35mm(1/4")	50mm L	100/1000		1.4/15.0
44-493	7mm	6.35mm(1/4")	50mm L	100/1000		1.5/16.0
44-494	8mm	6.35mm(1/4")	50mm L	100/1000		1.6/17.0
44-495	10mm	6.35mm(1/4")	50mm L	100/1000		2.4/25.0



Power Bits

■ TORX® Power Bits - 1/4" Hex x 50mm L

Item No.	Pt. Size	Shank Dia.	Overall Length		 kgs
44-506	T-10	6.35mm(1/4")	50mm L	100/1000	1.4/15.0
44-507	T-15	6.35mm(1/4")	50mm L	100/1000	1.4/15.0
44-508	T-20	6.35mm(1/4")	50mm L	100/1000	1.4/15.0
44-509	T-25	6.35mm(1/4")	50mm L	100/1000	1.4/15.0
44-510	T-27	6.35mm(1/4")	50mm L	100/1000	1.5/16.0
44-511	T-30	6.35mm(1/4")	50mm L	100/1000	1.5/16.0
44-513	T-40	6.35mm(1/4")	50mm L	100/1000	1.6/17.0
44-514	T-45	6.35mm(1/4")	50mm L	100/1000	2.1/22.0
44-515	T-50	6.35mm(1/4")	50mm L	100/1000	2.1/22.0



■ TORX® Tamper Proof Power Bits - 1/4" Hex x 50mm L

Item No.	Pt. Size	Shank Dia.	Overall Length		 kgs
44-526	T-10	6.35mm(1/4")	50mm L	100/1000	1.4/15.0
44-527	T-15	6.35mm(1/4")	50mm L	100/1000	1.4/15.0
44-528	T-20	6.35mm(1/4")	50mm L	100/1000	1.4/15.0
44-529	T-25	6.35mm(1/4")	50mm L	100/1000	1.4/15.0
44-530	T-27	6.35mm(1/4")	50mm L	100/1000	1.5/16.0
44-531	T-30	6.35mm(1/4")	50mm L	100/1000	1.5/16.0
44-533	T-40	6.35mm(1/4")	50mm L	100/1000	1.6/17.0
44-534	T-45	6.35mm(1/4")	50mm L	100/1000	2.1/22.0
44-535	T-50	6.35mm(1/4")	50mm L	100/1000	2.1/22.0



■ POZIDRIV® Power Bits - 1/4" Hex x 50mm L

Item No.	Pt. Size	Shank Dia.	Overall Length		 kgs
44-540	PZ0	6.35mm(1/4")	50mm L	100/1000	1.4/15.0
44-541	PZ1	6.35mm(1/4")	50mm L	100/1000	1.4/15.0
44-542	PZ2	6.35mm(1/4")	50mm L	100/1000	1.5/16.0
44-543	PZ3	6.35mm(1/4")	50mm L	100/1000	1.5/16.0
44-544	PZ4	6.35mm(1/4")	50mm L	100/1000	1.7/18.0



■ Square Recess Power Bits - 1/4" Hex x 50mm L

Item No.	Pt. Size	Shank Dia.	Overall Length		 kgs
44-570	S0	6.35mm(1/4")	50mm L	100/1000	1.4/15.0
44-571	S1	6.35mm(1/4")	50mm L	100/1000	1.4/15.0
44-572	S2	6.35mm(1/4")	50mm L	100/1000	1.5/16.0
44-573	S3	6.35mm(1/4")	50mm L	100/1000	1.6/17.0

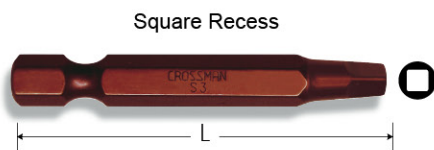

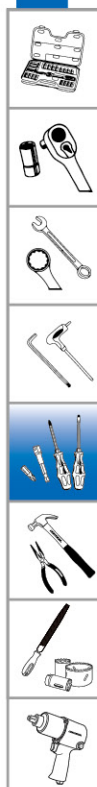

Power Bits

Round Shank Phillips Power Bits - 1/4" Hex x 50mm L

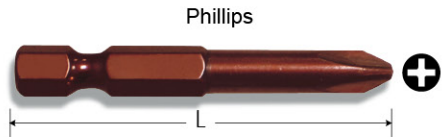

Item No.	Pt. Size	Shank Dia.	Overall Length			kgs
44-600	PH0	6.35mm(1/4")	50mm L	100/1000		1.5/16.0
44-601	PH1	6.35mm(1/4")	50mm L	100/1000		1.5/16.0
44-602	PH2	6.35mm(1/4")	50mm L	100/1000		1.5/16.0
44-603	PH3	6.35mm(1/4")	50mm L	100/1000		1.6/17.0
44-604	PH4	6.35mm(1/4")	50mm L	100/1000		1.7/18.0

Round Shank Slotted Power Bits (Metric) - 1/4" Hex x 50mm L

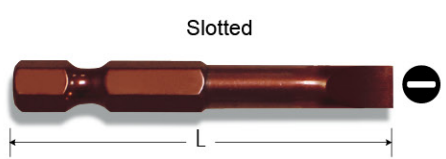

Item No.	Pt. Size	Shank Dia.	Overall Length			kgs
44-613	3mm	6.35mm(1/4")	50mm L	100/1000		1.4/15.0
44-614	4mm	6.35mm(1/4")	50mm L	100/1000		1.4/15.0
44-615	4.5mm	6.35mm(1/4")	50mm L	100/1000		1.4/15.0
44-616	5mm	6.35mm(1/4")	50mm L	100/1000		1.4/15.0
44-617	5.5mm	6.35mm(1/4")	50mm L	100/1000		1.4/15.0
44-618	6mm	6.35mm(1/4")	50mm L	100/1000		1.4/15.0
44-619	6.5mm	6.35mm(1/4")	50mm L	100/1000		1.5/16.0
44-620	7mm	6.35mm(1/4")	50mm L	100/1000		1.5/16.0
44-621	8mm	6.35mm(1/4")	50mm L	100/1000		1.6/17.0
44-622	10mm	6.35mm(1/4")	50mm L	100/1000		2.3/24.0

Round Shank Hex Power Bits (SAE) - 1/4" Hex x 50mm L

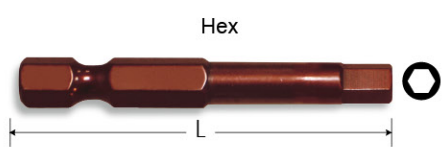

Item No.	Pt. Size	Shank Dia.	Overall Length			kgs
44-631	1/16"	6.35mm(1/4")	50mm L	100/1000		1.4/15.0
44-632	5/64"	6.35mm(1/4")	50mm L	100/1000		1.4/15.0
44-633	3/32"	6.35mm(1/4")	50mm L	100/1000		1.4/15.0
44-634	7/64"	6.35mm(1/4")	50mm L	100/1000		1.4/15.0
44-635	1/8"	6.35mm(1/4")	50mm L	100/1000		1.4/15.0
44-636	9/64"	6.35mm(1/4")	50mm L	100/1000		1.4/15.0
44-637	5/32"	6.35mm(1/4")	50mm L	100/1000		1.4/15.0
44-638	3/16"	6.35mm(1/4")	50mm L	100/1000		1.4/15.0
44-639	7/32"	6.35mm(1/4")	50mm L	100/1000		1.4/15.0
44-640	1/4"	6.35mm(1/4")	50mm L	100/1000		1.5/16.0
44-641	9/32"	6.35mm(1/4")	50mm L	100/1000		1.5/16.0
44-642	5/16"	6.35mm(1/4")	50mm L	100/1000		1.6/17.0
44-643	3/8"	6.35mm(1/4")	50mm L	100/1000		2.4/25.0

Round Shank Hex Power Bits (Metric) - 1/4" Hex x 50mm L

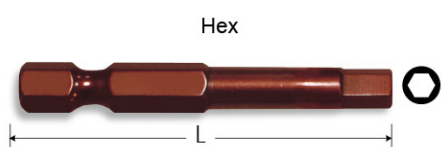

Item No.	Pt. Size	Shank Dia.	Overall Length			kgs
44-645	1.5mm	6.35mm(1/4")	50mm L	100/1000		1.4/15.0
44-646	2mm	6.35mm(1/4")	50mm L	100/1000		1.4/15.0
44-647	2.5mm	6.35mm(1/4")	50mm L	100/1000		1.4/15.0
44-648	3mm	6.35mm(1/4")	50mm L	100/1000		1.4/15.0
44-649	4mm	6.35mm(1/4")	50mm L	100/1000		1.4/15.0
44-650	5mm	6.35mm(1/4")	50mm L	100/1000		1.4/15.0
44-651	5.5mm	6.35mm(1/4")	50mm L	100/1000		1.4/15.0
44-652	6mm	6.35mm(1/4")	50mm L	100/1000		1.4/15.0
44-653	7mm	6.35mm(1/4")	50mm L	100/1000		1.5/16.0
44-654	8mm	6.35mm(1/4")	50mm L	100/1000		1.6/17.0
44-655	10mm	6.35mm(1/4")	50mm L	100/1000		2.4/25.0

Power Bits

■ Round Shank TORX® Power Bits - 1/4" Hex x 50mm L

Item No.	Pt. Size	Shank Dia.	Overall Length			kgs
44-706	T-10	6.35mm(1/4")	50mm L	100/1000		1.4/15.0
44-707	T-15	6.35mm(1/4")	50mm L	100/1000		1.4/15.0
44-708	T-20	6.35mm(1/4")	50mm L	100/1000		1.4/15.0
44-709	T-25	6.35mm(1/4")	50mm L	100/1000		1.4/15.0
44-710	T-27	6.35mm(1/4")	50mm L	100/1000		1.5/16.0
44-711	T-30	6.35mm(1/4")	50mm L	100/1000		1.5/16.0
44-713	T-40	6.35mm(1/4")	50mm L	100/1000		1.6/17.0
44-714	T-45	6.35mm(1/4")	50mm L	100/800		2.4/21.0
44-715	T-50	6.35mm(1/4")	50mm L	100/800		2.4/21.0



■ Round Shank TORX® Tamper Proof Power Bits - 1/4" Hex x 50mm L

Item No.	Pt. Size	Shank Dia.	Overall Length			kgs
44-726	T-10	6.35mm(1/4")	50mm L	100/1000		1.4/15.0
44-727	T-15	6.35mm(1/4")	50mm L	100/1000		1.4/15.0
44-728	T-20	6.35mm(1/4")	50mm L	100/1000		1.4/15.0
44-729	T-25	6.35mm(1/4")	50mm L	100/1000		1.4/15.0
44-730	T-27	6.35mm(1/4")	50mm L	100/1000		1.5/16.0
44-731	T-30	6.35mm(1/4")	50mm L	100/1000		1.5/16.0
44-733	T-40	6.35mm(1/4")	50mm L	100/1000		1.6/17.0
44-734	T-45	6.35mm(1/4")	50mm L	100/800		2.4/21.0
44-735	T-50	6.35mm(1/4")	50mm L	100/800		2.4/21.0





■ Round Shank POZIDRIV® Power Bits - 1/4" Hex x 50mm L

Item No.	Pt. Size	Shank Dia.	Overall Length			kgs
44-740	PZ0	6.35mm(1/4")	50mm L	100/1000		1.4/15.0
44-741	PZ1	6.35mm(1/4")	50mm L	100/1000		1.4/15.0
44-742	PZ2	6.35mm(1/4")	50mm L	100/1000		1.5/16.0
44-743	PZ3	6.35mm(1/4")	50mm L	100/1000		1.5/16.0
44-744	PZ4	6.35mm(1/4")	50mm L	100/1000		1.7/18.0



■ Round Shank Square Recess Power Bits - 1/4" Hex x 50mm L

Item No.	Pt. Size	Shank Dia.	Overall Length			kgs
44-770	S0	6.35mm(1/4")	50mm L	100/1000		1.4/15.5
44-771	S1	6.35mm(1/4")	50mm L	100/1000		1.4/15.5
44-772	S2	6.35mm(1/4")	50mm L	100/1000		1.5/16.0
44-773	S3	6.35mm(1/4")	50mm L	100/1000		1.6/17.0

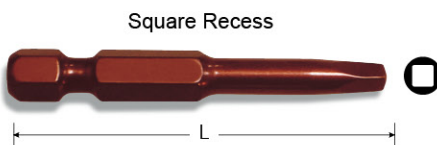



Power Bits

Phillips Double End Bits- 1/4" Hex

Item No.	Pt. Size	Shank Dia.	Overall Length			kgs
48-649	PH1	6.35mm(1/4")	45mm L	100/1500	0.9/14.5	
48-650	PH2	6.35mm(1/4")	45mm L	100/1500	0.9/14.5	
48-648	PH1	6.35mm(1/4")	65mm L	100/1500	1.5/16.0	
48-651	PH2	6.35mm(1/4")	65mm L	100/1000	1.5/16.0	
48-652	PH3	6.35mm(1/4")	65mm L	100/1000	1.5/16.0	
48-659	PH2	6.35mm(1/4")	110mm L	100/500	2.7/14.5	
48-653	PH3	6.35mm(1/4")	110mm L	100/500	2.7/14.5	
48-660	PH2	6.35mm(1/4")	150mm L	100/500	3.7/19.0	
48-655	PH3	6.35mm(1/4")	150mm L	100/500	3.7/19.0	
48-661	PH2	6.35mm(1/4")	200mm L	100/300	5.0/16.5	
48-654	PH3	6.35mm(1/4")	200mm L	100/300	5.0/16.5	
48-656	PH2	6.35mm(1/4")	250mm L	100/300	7.0/20.5	
48-657	PH3	6.35mm(1/4")	250mm L	100/300	7.0/20.5	
48-662	PH2	6.35mm(1/4")	300mm L	100/200	8.0/16.5	
48-665	PH3	6.35mm(1/4")	300mm L	100/200	8.0/16.5	

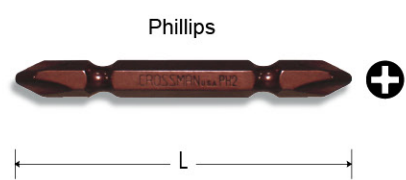

Phillips Impact Driver Bits - 5/16" Hex x 36mm L

Item No.	Pt. Size	Shank Dia.	Overall Length			kgs
48-361	PH1	8mm(5/16")	36mm L	100/1000	1.5/16.0	
48-362	PH2	8mm(5/16")	36mm L	100/1000	1.5/16.0	
48-363	PH3	8mm(5/16")	36mm L	100/1000	1.5/16.0	
48-364	PH4	8mm(5/16")	36mm L	100/1000	1.5/16.0	

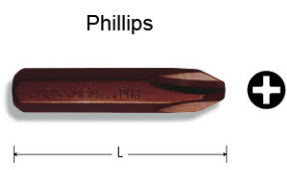

Slotted Impact Driver Bits - 5/16" Hex x 36mm L

Item No.	Pt. Size	Shank Dia.	Overall Length			kgs
48-368	8mm	8mm(5/16")	36mm L	100/1000	1.4/14.5	
48-370	10mm	8mm(5/16")	36mm L	100/1000	2.0/20.0	
48-371	12mm	8mm(5/16")	36mm L	100/1000	3.0/14.5	

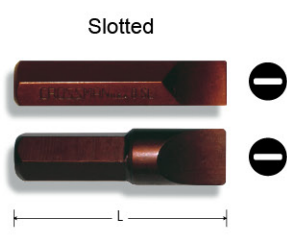

Phillips Impact Driver Bits - 5/16" Hex x 80mm L

Item No.	Pt. Size	Shank Dia.	Overall Length			kgs
48-801	PH1	8mm(5/16")	80mm L	100/500	3.5/18.0	
48-802	PH2	8mm(5/16")	80mm L	100/500	3.5/18.0	
48-803	PH3	8mm(5/16")	80mm L	100/500	3.5/18.0	
48-804	PH4	8mm(5/16")	80mm L	100/500	3.5/18.0	

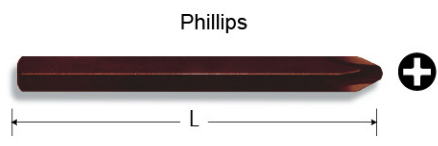

Slotted Impact Driver Bits - 5/16" Hex x 80mm L

Item No.	Pt. Size	Shank Dia.	Overall Length			kgs
48-808	8mm	8mm(5/16")	80mm L	100/500	3.5/18.0	
48-810	10mm	8mm(5/16")	80mm L	100/500	4.5/23.0	

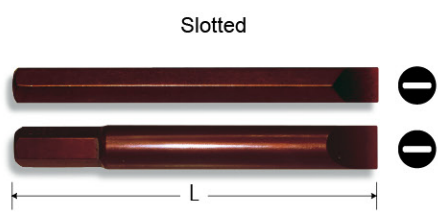



Fastener Drive Tool Sets

Professional Impact Driver Set With Bits - 5 Pcs.

Item No.		kgs
48-105	1/20	1.0/20.0

- 1 Pc. Impact Driver Handle.
- 4 Pcs. Impact Drive Bits: 8mm (5/16") Hex x 36mm L
 - ⊕ Phillips: PH2, PH3.
 - ⊖ Slotted: 8, 10mm.

▲ Blow Mold Box

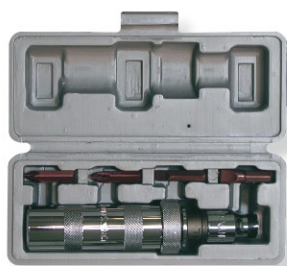

Impact Driver Set With Bits - 5 Pcs.

Item No.		kgs
48-005	1/20	0.9/19.0

- 1 Pc. Impact Driver Handle.
- 4 Pcs. Impact Drive Bits: 8mm (5/16") Hex x 36mm L
 - ⊕ Phillips: PH2, PH3.
 - ⊖ Slotted: 8, 10mm.

▲ Blow Mold Box



Impact Driver Set With Bits - 14 Pcs.

Item No.		kgs
48-014	1/20	1.3/24.8

- 1 Pc. Impact Driver Handle.
- 12 Pcs. Impact Drive Bits: 8mm (5/16") Hex x 36mm L
 - ⊕ Phillips: PH1, PH2, PH3, PH4.
 - Hex: 4, 5, 6, 8mm.
 - ⊖ Slotted: 6, 8, 10, 12mm.
- 1 Pc. ○ 3/8" Dr. Ball-Lock Socket Adapter: 3/8" Hex x 30mm L.

▲ Blow Mold Box



14 in 1 Flexible (Pistol) Ratchet Screwdriver Set

Item No.		kgs
46-606	6/48	1.8/15.4

- 1 Pc. Flexiable Ratchet Screwdriver.
 - ** Magnetic bit holder.
- 1 Pc. Knurled Shank Magnetic Bit Holder: 1/4" Hex x 63mm L.
- 7 Pcs. Insert Bits: 6.35mm (1/4") Hex x 25mm L
 - ⊕ Phillips: PH2.
 - ⊕ Phillips: PH2. **DIAMOND TIP®**
 - ⊖ Slotted: 6mm.
 - Hex: 3, 4, 5, 6mm.



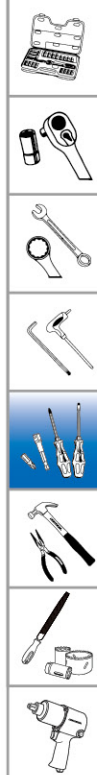

Fastener Drive Tool Sets

9 in 1 Ratchet Screwdriver Set



Item No.		 kgs
46-601	6/48	1.4/12.2

- 1 Pc. Ratchet Screwdriver handle.
** 2" in depth of bit storage housing.
** Magnetic bit holder.
- 9 Pcs. Insert Bits: 6.35mm (1/4") Hex x 25mm L
 - ⊕ Phillips: PH0, PH1, PH2, PH3.
 - ◆ ⊕ Phillips: PH2. **DIAMOND TIP®**
 - ⊖ Slotted: 3, 4, 5, 6mm.

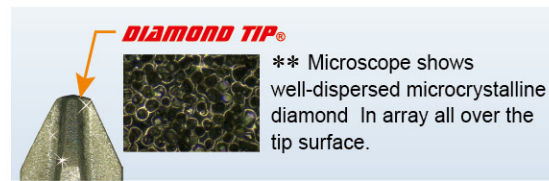

13 in 1 Extendable Ratchet Screwdriver Set



Item No.		 kgs
46-605	6/48	1.6/13.8

- 1 Pc. Extendable Ratchet Screwdriver (70~140mm).
** 2" in depth of bit storage housing.
** Magnetic bit holder.
- 13 Pcs. Insert Bits: 6.35mm (1/4") Hex x 25mm L
 - ⊕ Phillips: PH0, PH1, PH2, PH3.
 - ◆ ⊕ Phillips: PH2. **DIAMOND TIP®**
 - ⊖ Slotted: 3, 4, 5, 6mm.
 - ⊛ POZIDRIV®: PZ0, PZ1, PZ2, PZ3.

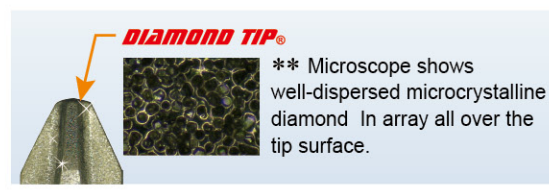
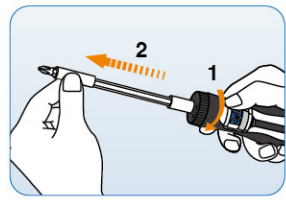

19 in 1 Functions Ratchet Screwdriver Set



Item No.	Size		 kgs
46-700	5mm x 100mm	6/54	2.8/25

- 1 Pc. Ratchet Screwdriver.
- 7 Pcs. 1/4" (6.35mm) x 75mm Bits

Size: ⊖ 5mm	⊕ PH1	⊛ PZ1	⊛ PZ2
⊖ 6mm	⊕ PH2	○ 2.5mm	○ 3mm
⊛ T15	⊛ T20	○ 4mm	○ 5mm
⊛ T25	⊛ T30		
- 1 Pc. 5/16" (8mm) x 75mm Bits

Size: ⊖ 8mm	⊕ PH3
-------------	-------

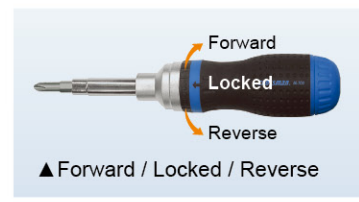



Fastener Drive Tool Sets

■ Air Impact Driver Bit Set - 40 Pcs.

Item No.		 kgs
48-040	1/10	1.8/19.0

- 1 Pc. Quick Release Bit Holder: 1/2" Dr. x 3/8"(10mm) Hex.
- 20 Pcs. Insert Bits: 3/8"(10mm) Hex x 30mm L
 - Hex: 4, 5, 6, 7, 8, 10,12 mm.
 - Spline: M5, M6, M8, M10, M12.
 - ⊕ TORX[®] Tamper Proof: T20, T25, T30, T40, T45, T50, T55, T60.
- 19 Pcs. Insert Bits: 3/8"(10mm) Hex x 75mm L
 - Hex: 4, 5, 6, 7, 8, 10,12 mm.
 - Spline: M5, M6, M8, M10, M12.
 - ⊕ TORX[®] Tamper Proof: T20, T25, T30, T40, T45, T50, T55.

■ 1/4" Drive Socket & Bit Set - 61 Pcs.

Item No.		 kgs
87-012	1/12	1.2/15.0

- 1 Pc. Flexible Ratchet Screwdriver. **Magnetic Bit Holder.
- 1 Pc. Ball-Lock Socket Adapter: 1/4"Hex x 25mm L.
- 1 Pc. Knurled Shank Magnetic Bit Holder: 1/4" Hex x 63mm L.
- 1 Pc. 3" Extension.
- 12 Pcs. Sockets (Metric Size, 6-Point):
4, 4.5, 5, 5.5, 6, 7, 8, 9, 10, 11, 12, 13 mm.
- 10 Pcs. Sockets (SAE Size, 6-Point):
5/32", 3/16", 7/32", 1/4", 9/32", 5/16", 11/32", 3/8", 7/16", 1/2".
- 35 Pcs. Insert Bits: 1/4"Hex x 25mm L
 - ⊖ Slotted: 3, 4, 5, 6, 7 mm.
 - ⊕ Phillips: PH0, PH1, PH2, PH3.
 - ◆ ⊕ Phillips: PH2 **DIAMOND TIP[®]**
 - ⊕ POZIDRIV[®] : PZ0, PZ1, PZ2, PZ3.
 - ◆ ⊕ POZIDRIV[®] : PZ2 **DIAMOND TIP[®]**
 - Hex: 1.5, 2, 2.5, 3, 4, 5, 5.5, 6 mm.
 - ⊕ TORX[®] Tamper Proof: T5, T6, T7, T8, T9, T10, T15, T20, T25, T27, T30, T40.

▲ Blow Mold Box



Fastener Drive Tool Sets

■ Screwdriver Bit Set - 100 Pcs.

Item No.		 kgs
99-061	1/20	0.8/16.0



- 1 Pc. Magnetic Bit Holder: 1/4" Hex x 60mm L.
- 2 Pcs. 1/4" Dr. Ball-Lock Socket Adapter:
1/4" Hex x 25mm L & 1/4" Hex x 50mm L.
- 1 Pc. Quick Release Bit Holder: 1/4" Dr. x 1/4" Hex.
- 1 Pc. "Y" Type Spanner.
- 95 Pcs. Insert Bits: 1/4" Hex x 25mm L
 - ⊕ Phillips: PH0, PH1, PH2 (5 pcs.), PH3.
 - ⊕ POZIDRIV® : PZ0, PZ1, PZ2 (5 pcs.), PZ3.
 - ⊖ Slotted: 3, 4, 4.5, 5, 5.5, 6, 6.5, 7, 8 mm.
 - ⊕ TORX® : T8, T10, T15, T20, T25, T27, T30, T40, T45.
 - ⊕ TORX® Tamper Proof: T8, T10, T15, T20, T25, T27, T30, T35, T40.
 - Hex: 1.5, 2, 2.5, 3, 4, 5, 5.5, 6, 8 mm.
 - Hex: 1/16", 5/64", 3/32", 7/64", 1/8", 9/64", 5/32", 3/16", 7/32", 1/4".
 - ⊕ Hex Tamper Proof: 2, 2.5, 3, 4, 5, 6 mm.
 - ⊕ Hex Tamper Proof: 5/64", 3/32", 7/64", 1/8", 9/64", 5/32".
 - ⊕ Spanner: SP4, SP6, SP8, SP10.
 - ⊕ TRI-WING® : TW1, TW2, TW3, TW4.
 - ⊕ TORQ-SET® : TS6, TS8, TS10.
 - Square Recess: S0, S1, S2, S3.
 - Spline: M5, M6, M8.
 - ⊖ Clutch C: C1, C2, C3.

▲ Blow Mold Box



HAND TOOLS



P137 High Leverage

P138 Pliers

P145 Premium Grade Locking Pliers

P146 Professional Grade Locking Pliers

P148 Hand Tools

P161 Tool Boxes / Roller Cabinet



High Leverage

Multi Lineman's Pliers

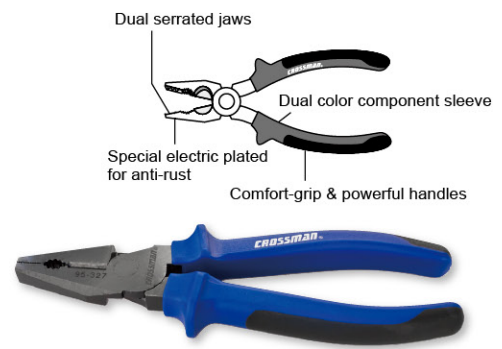

Item No.	Size		
95-326	6"	5	100
95-327	7"	5	50
95-328	8"	5	50

Long Nose Pliers

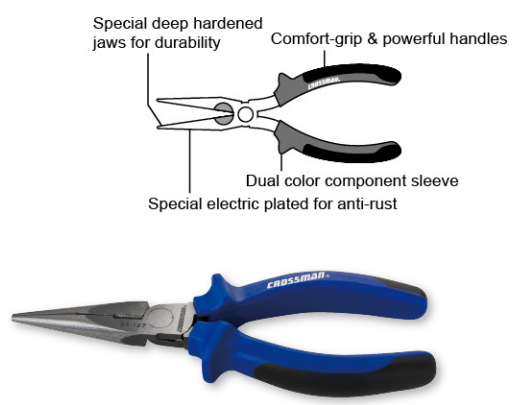

Item No.	Size		
95-127	6-1/2"	6	60

Diagonal Cutting Pliers

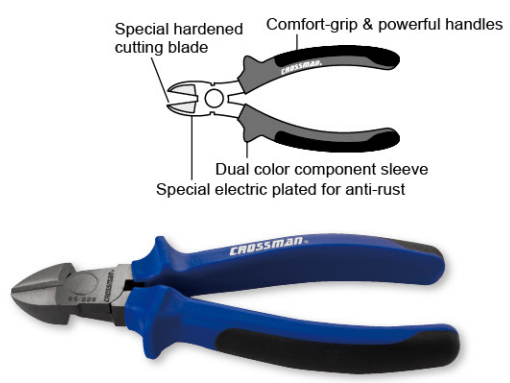

Item No.	Size		
95-228	6-1/2"	6	60

High Leverage Lineman's Pliers



Item No.	Size		
95-285	10"	6	36

- *** High leverage pivot joint generates up to 40% more cutting power than regular pliers.
- *** Hardened cutting edge for long life featuring less efforts for high performance.

Graphic

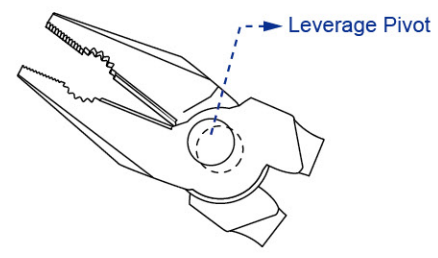

Heavy Duty Diagonal Cutting Pliers

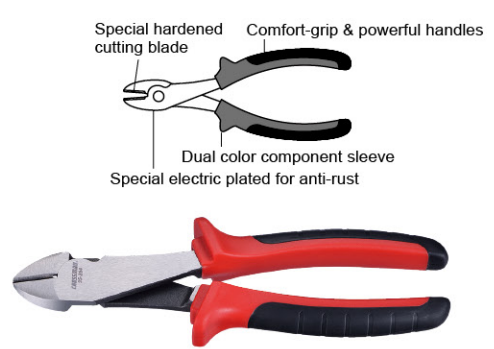

◆ Ergonomic design on handle for less muscle fatigue.

Item No.	Size		
95-264	8"	6	60

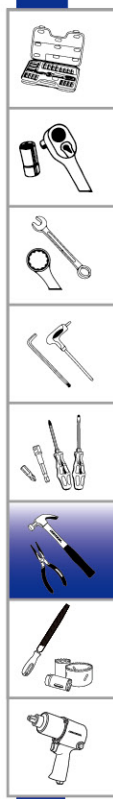

Long Nose Pliers

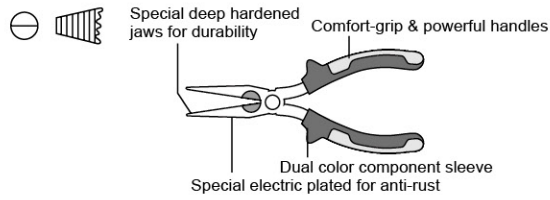

Item No.	Size		
95-115	5-1/2"	5	100
95-116	6-1/2"	5	100
95-118	7-1/2"	5	50

Lineman's Pliers

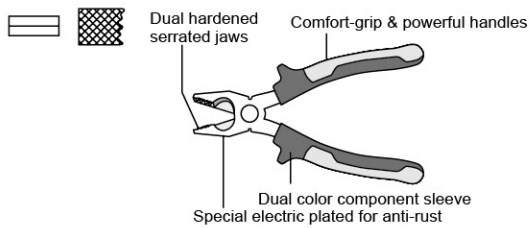

Item No.	Size		
95-316	6"	5	100
95-317	7"	5	50
95-318	8"	5	50

Slip Joint Pliers

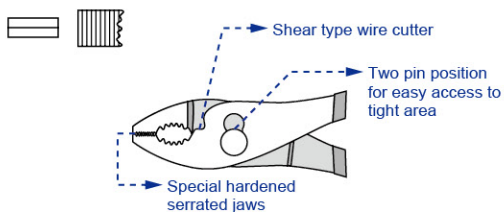

Item No.	Size		
95-406	6"	12	96
95-408	8"	12	60
95-410	10"	12	48

Diagonal Cutting Pliers

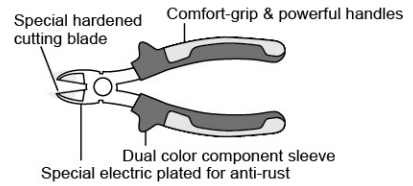

Item No.	Size		
95-215	5-1/2"	5	100
95-216	6-1/2"	5	100
95-217	7-1/2"	5	50

Multi Lineman's Pliers

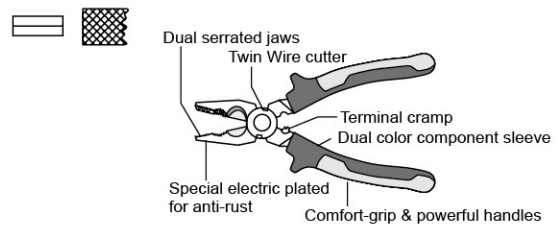

Item No.	Size		
95-519	9"	5	50

Water Pump Pliers

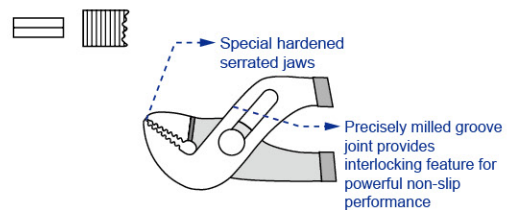

Item No.	Size		
95-808	8"	12	60
95-810	10"	12	48
95-812	12"	12	36





Pliers

Long Nose Pliers

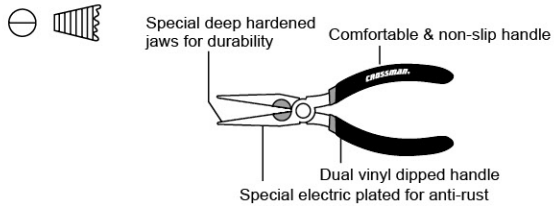

Item No.	Size		
95-105	5-1/2"		5/100
95-106	6-1/2"		5/100
95-108	7-1/2"		5/50

Lineman's Pliers

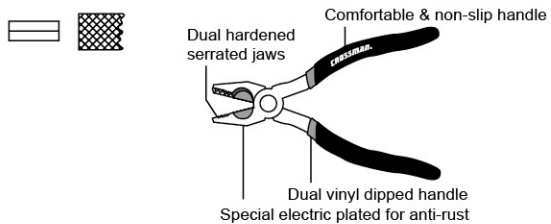

Item No.	Size		
95-306	6"		5/100
95-307	7"		5/50
95-308	8"		5/50

Multi-Function Lineman's Pliers

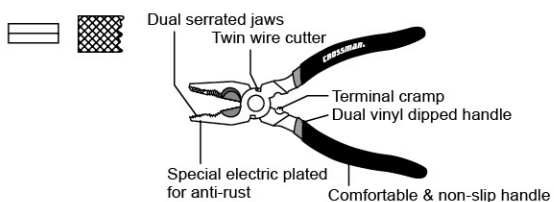

Item No.	Size		
95-509	9"		5/50

Diagonal Cutting Pliers

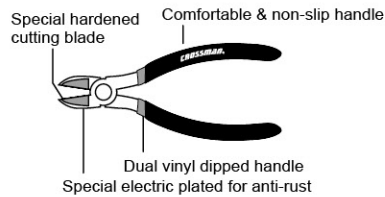

Item No.	Size		
95-205	5-1/2"		5/100
95-206	6-1/2"		5/100
95-207	7-1/2"		5/50

Diagonal Precision Cutting Pliers For Electronics (curved)

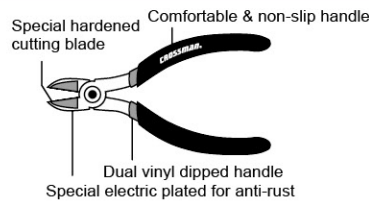

Item No.	Size		
95-235	6-1/2"		5/100

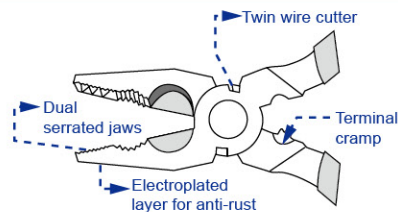

Stamped Crossman logo

Stamped Crossman logo on the handle for genuine Crossman products: 95-115, 95-116, 95-118, 95-215, 95-216, 95-217, 95-316, 95-317, 95-318, 95-519, 95-105, 95-106, 95-108, 95-205, 95-206, 95-207, 95-306, 95-307, 95-308, 95-509, 95-528, 95-538, 95-539, 95-549, 95-548, 95-558, 95-559, 95-569



Miniature Pliers

Miniature Long Nose Pliers

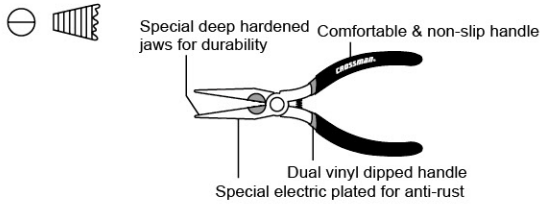

Item No.	Size		
95-104	4-3/4"	5	100

Miniature Diagonal Cutting Pliers

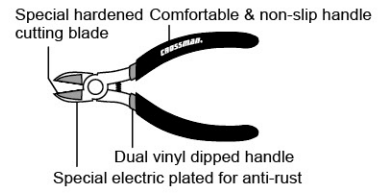

Item No.	Size		
95-204	4-1/2"	5	100

Miniature Bent Nose Pliers

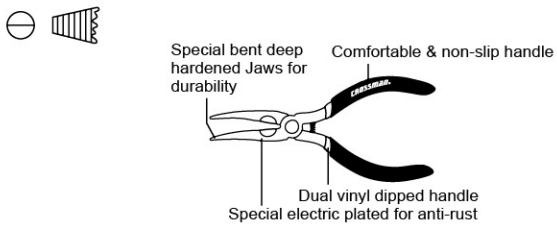

Item No.	Size		
95-411	5"	5	100

Miniature End Nipper Pliers

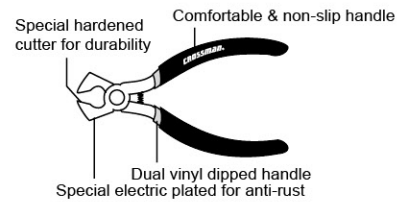

Item No.	Size		
95-412	4-1/2"	5	100

Miniature Flat Nose Pliers

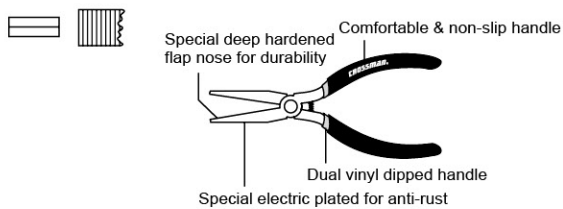

Item No.	Size		
95-413	5"	5	100

Miniature Lineman's Pliers

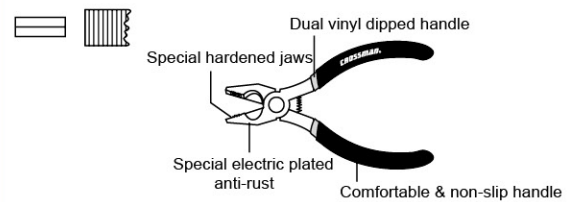

Item No.	Size		
95-414	5"	5	100



Multi-Function Electrician's Pliers with Wire Striping & Crimping Dies



Item No.	Size	
95-528	8-1/2"	5/50

Multi-Function Cutting Pliers with Crimping Dies



Item No.	Size	
95-538	8"	5/50

Multi-Function Heavy Duty Linesman Pliers for Rebar Work



Item No.	Size	
95-539	9-1/2"	5/50

Multi-Function Powerful Linesman Pliers with Crimping Dies



Item No.	Size	
95-549	9-1/2"	5/50

Graphic

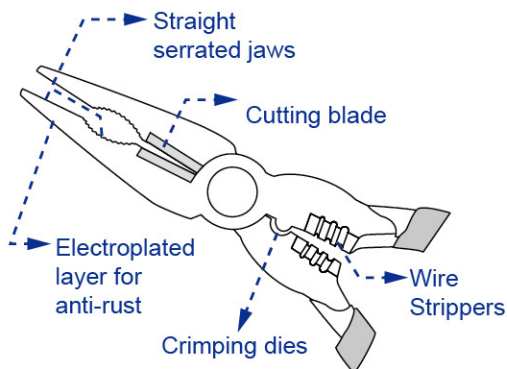

Graphic

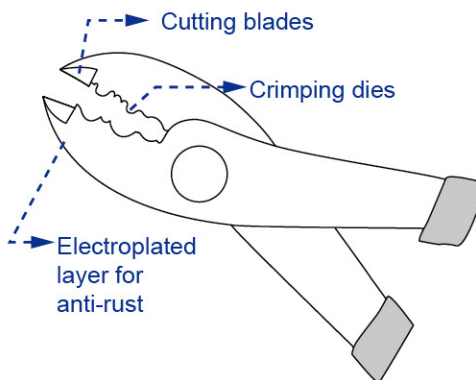

Graphic

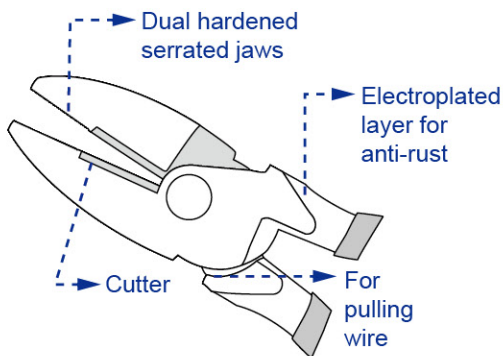

Graphic

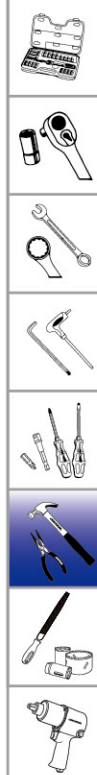
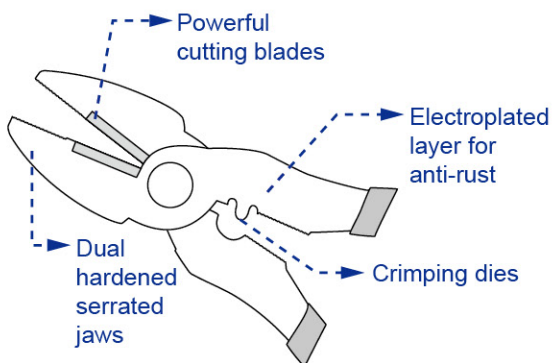

Multi-Function Electrician's Pliers with Wire Striping & Crimping Dies



- ◆ Crimping dies of 2.5~6.0 mm²
- ◆ Strippers for wire of 1.5~2.5 mm²

Item No.	Size	
95-548	8-1/2"	5/50

Graphic

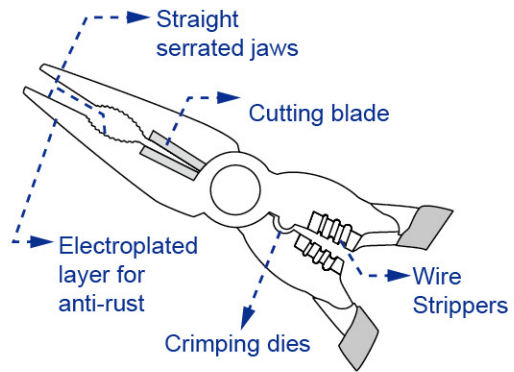

Multi-Function Cutting Pliers with Crimping Dies



- ◆ Crimping dies of 1.5~6.0 mm²

Item No.	Size	
95-558	8-1/4"	5/50

Graphic

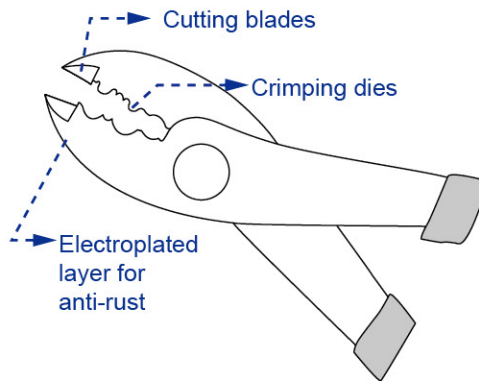

Multi-Function Heavy Duty Linesman Pliers for Rebar Work



- ◆ For pulling wire of 1.0~2.0 mm²

Item No.	Size	
95-559	9-1/2"	5/50

Graphic

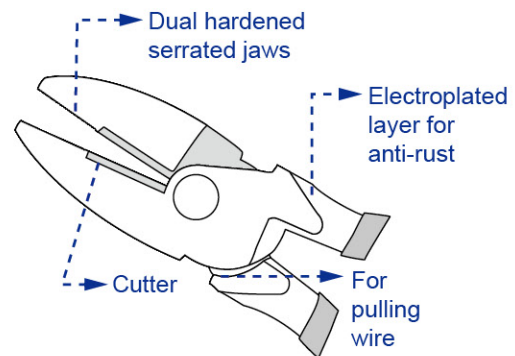

Multi-Function Powerful Linesman Pliers with Crimping Dies



- ◆ Crimping dies of 4.0~10.0 mm²

Item No.	Size	
95-569	9-1/2"	5/50

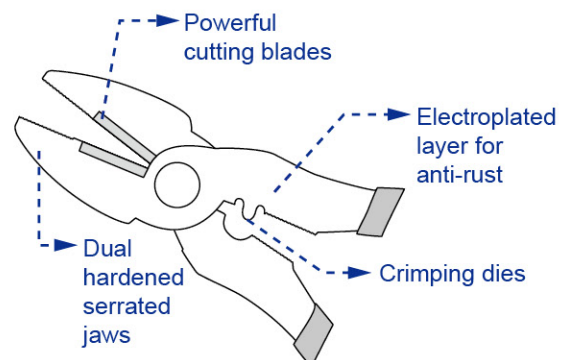

Graphic



Snap Ring Pliers



External Straight



Item No.	Size	Capacity	 
95-171	5-1/2"	10-25 mm	5/50
95-151	7"	19-60 mm	5/50
95-191	9"	40-100 mm	5/50

External 90 Degree Bent



Item No.	Size	Capacity	 
95-173	5-1/2"	10-25 mm	5/50
95-153	7"	19-60 mm	5/50
95-193	9"	40-100 mm	5/50



Multi - Function Snap Ring Plier - 6 in 1



Item No.	 
94-006	12/48



Internal Straight



Item No.	Size	Capacity	 
95-172	5-1/2"	10-25 mm	5/50
95-152	7"	10-45 mm	5/50
95-192	9"	32-80 mm	5/50

Internal 90 Degree Bent



Item No.	Size	Capacity	 
95-174	5-1/2"	10-25 mm	5/50
95-154	7"	19-60 mm	5/50
95-194	9"	40-100 mm	5/50

Graphic

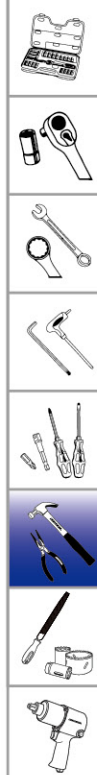
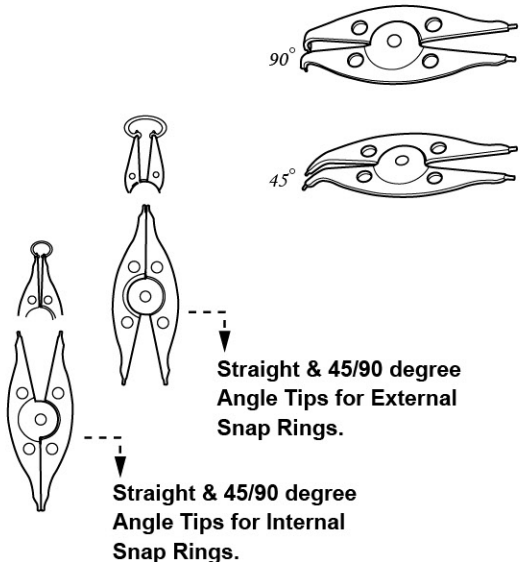

Pliers

Mini Heavy Duty Bolt Cutter



Item No.	Size		
94-390	8"	Ø2 mm	6/30

Mini Bolt Cutter



Item No.	Size		
94-391	8"	Ø2 mm	6/60

Mini Wire Rope Cutter



Item No.	Size		
94-392	8"	Ø5 mm	6/60

Precision Diagonal Cutter Pliers



Item No.	Size		
94-702	3-1/2"		10/200

Precision Diagonal Cutter Pliers



Item No.	Size		
94-701	4-1/2"		10/200

Precision Diagonal Cutter Pliers



Item No.	Size		
94-711	5"		10/200



Pliers / Premium Grade Locking Pliers

Helical Curved Jaw Locking Pliers



• Chrome vanadium steel

Item No.	Type	Size		
94-105	CRW5	5"		12/120
94-107	CRW7	7"		5/50
94-110	CRW10	10"		6/36

Long Nose Locking Pliers



• Chrome vanadium steel

Item No.	Type	Size		
94-406	CLN6	6"		12/120
94-409	CLN9	9"		12/48

Locking "C" Clamp With Regular Tips



Item No.	Type	Size		
94-436	CRC6	6"		12/72
94-441	CRC11	11"		10/30
94-448	CRC18	18"		12/24

Welding Clamp



Item No.	Type	Size		
94-429	CWC9	9"		6/36
94-431	CWC11	11"		5/30

Straight Jaw Locking Pliers



• Chrome vanadium steel

Item No.	Type	Size		
94-507	CR7	7"		5/50
94-510	CR10	10"		6/36

Metal Sheet Clamp



• Chrome vanadium steel

Item No.	Type	Size		
94-418	CRC8	8"		6/36
94-420	CRC10	10"		5/30

Locking "C" Clamp with Swivel Pads



Item No.	Type	Size		
94-454	CP4	4"		24/96
94-456	CP6	6"		12/72
94-461	CP11	11"		10/30
94-468	CP18	18"		12/24

Locking Chain Clamp





Item No.	Type	Size		
94-470	CCR20	19"		5/30



Helical Curved Jaw Locking Pliers





- Heat treatment for jaws

Item No.	Type	Size	 
94-155	5WR	5"	10/100
94-157	7WR	7"	10/50
94-150	10WR	10"	10/50

Straight Jaw Locking Pliers



- Heat treatment for jaws

Item No.	Type	Size	 
94-167	7R	7"	10/100
94-550	10R	10"	10/50



Long Nose Locking Pliers



Item No.	Type	Size	 
94-176	6P	6"	10/100



Metal Sheet Clamp



Item No.	Type	Size	 
94-188	CR8	8"	1/40



Locking "C" Clamp With Regular Tips



Item No.	Type	Size	 
94-246	CR6	6"	1/72
94-251	CR11	11"	10/30
94-258	CR18	18"	5/20

Locking "C" Clamp with Swivel Pads



Item No.	Type	Size	 
94-266	CSP6	6"	1/72
94-271	CSP11	11"	10/30
94-278	CSP18	18"	5/20



Welding Clamp



Item No.	Type	Size	 
94-239	CR9	9"	1/30

Locking Chain Clamp



Item No.	Type	Size	 
94-280	CR20	19"	12/24





Crimping Pliers



Item No.	Size	
95-281	7"	6/72
95-282	10"	6/36

FEATURES:

Idea For Terminal Types as follows:

- * Ring Terminal
- * Y Terminal
- * Pin Terminal
- * Non-Insulated Terminal
- * Copper Tube Terminal
- * Cable Lugs CI-Type1-Hole For High Voltage
- * Cable Lugs CI-Type2-Hole For High Voltage

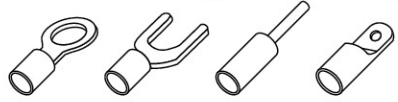

Item No.: 95-281
For Terminals: 1.25, 2, 3.5, 5.5 mm²
Item No.: 95-282
For Terminals: 1.25, 2, 5.5, 8, 14 mm²

PVC Pipe Cutter



Item No.	Length	
94-911	195mm	10/50

▲ For cutting pvc pipe up to 1-1/8" (36 mm)



Item No.	Length	
94-912	205mm	10/50

▲ For cutting pvc pipe up to 1-5/16" (42 mm)



◆ Triangle Blade

Item No.	Length	
94-913	205mm	10/50

▲ For cutting pvc pipe up to 1-5/16" (42 mm)

Multi-Purpose Modular Crimping Tools



Item No.	Size	
94-931	8P	10/40

Multi-Purpose Modular Crimping Tools



Item No.	Size	
94-941	4P	10/40

Graphic 94-931

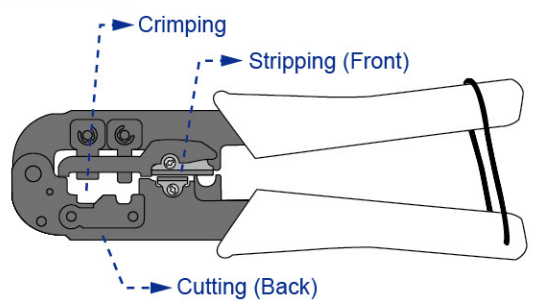

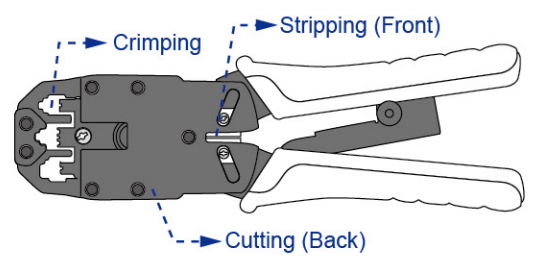

Graphic 94-941





Claw Hammer with Wood Handle



Item No.	Hand Weight	 
68-108	8 Oz	6/60
68-112	12 Oz	6/36
68-116	16 Oz	6/24
68-120	20 Oz	6/24



Claw Hammer with Fiberglass Handle



Item No.	Hand Weight	 
68-208	8 Oz	6/48
68-212	12 Oz	6/36
68-216	16 Oz	6/24
68-220	20 Oz	6/24



Ball Pein Hammer with Wood Handle



Item No.	Hand Weight	 
68-308	8 Oz	6/72
68-312	12 Oz	6/48
68-316	16 Oz	6/36
68-324	24 Oz	6/24
68-332	32 Oz	6/12
68-340	40 Oz	6/12
68-348	48 Oz	6/12

Engineer's Hammer (Machinist's Hammer)



Item No.	Hand Weight	 
68-831	100 Grams	6/72
68-832	200 Grams	6/60
68-833	300 Grams	6/48
68-834	400 Grams	6/48
68-835	500 Grams	6/36
68-836	600 Grams	6/36
68-838	800 Grams	6/24



Double-Faced Rubber Mallet Hammer



Item No.	Hand Weight	 
68-510	20 mm	6/60
68-511	25 mm	6/60
68-512	30 mm	6/36
68-514	35 mm	6/24
68-515	40 mm	6/24

Copper Hammer



Item No.	Hand Weight	 
68-708	8 Oz	6/24
68-712	12 Oz	6/24
68-716	16 Oz	6/24
68-724	24 Oz	6/12
68-732	32 Oz	2/12



Hand Tools

Sledge Hammer with Hard Wood Handle



Item No.	Hand Weight	 
68-401	1 Lbs.	6/24
68-402	2 Lbs.	6/12
68-404	4 Lbs.	1/6
68-406	6 Lbs.	1/6
68-408	8 Lbs.	1/6
68-410	10 Lbs.	1/4
68-412	12 Lbs.	1/4
68-414	14 Lbs.	1/2
68-416	16 Lbs.	1/2
68-420	20 Lbs.	1/2



Stone Hammer



Item No.	Hand Weight	 
68-431	2.20 Lbs.	4/12
68-432	2.75 Lbs.	4/12
68-433	3.30 Lbs.	4/12
68-434	4.40 Lbs.	4/12



Rubber Mallet Hammer



Item No.	Hand Weight	 
68-931	8 Oz	6/60
68-932	12 Oz	6/60
68-933	16 Oz	6/24
68-934	24 Oz	6/24
68-935	32 Oz	6/24



Bolt Cutter



Item No.	Size	 
94-314	14"	1/20
94-318	18"	1/10
94-324	24"	1/8
94-330	30"	1/5
94-336	36"	1/4
94-342	42"	1/2

Cable Cutter, Aluminium Handle



Item No.	Size	 
94-394	24"	1/10
94-395	28"	1/10
94-396	32"	1/6

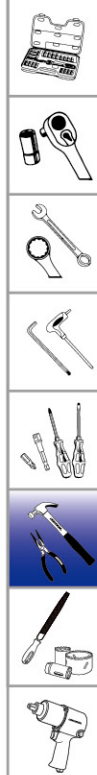

Diamond Tip® Aviation Snip (Left cutting)

 **DIAMOND TIP®**



Item No.	Size	 
49-921	10"	12/48

Aviation Snip (Left cutting)



Item No.	Size	 
94-921	10"	12/48

Diamond Tip® Aviation Snip (Right cutting)

 **DIAMOND TIP®**



Item No.	Size	 
49-922	10"	12/48

Aviation Snip (Right cutting)



Item No.	Size	 
94-922	10"	12/48

Diamond Tip® Aviation Snip (Straight cutting)

 **DIAMOND TIP®**



Item No.	Size	 
49-923	10"	12/48

Aviation Snip (Straight cutting)

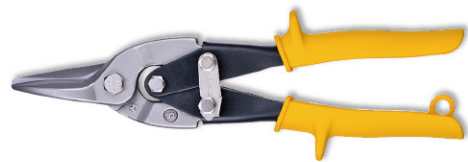

Item No.	Size	 
94-923	10"	12/48

Diamond layer on the blade



◆ Cutting edge prior to cutting.

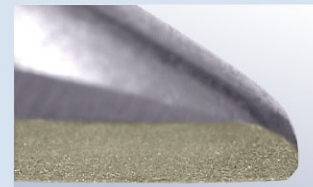

◆ Cutting edge still looks new even repeatedly cutting metal sheet 1.2mm in thickness.



Hand Tools

Quick Release Bar Clamp

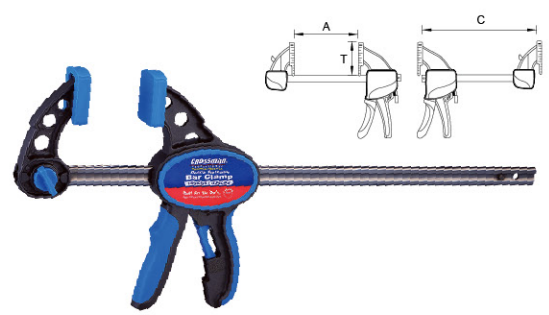

Item No.	Size(A)	Clamping Spreading	Throat depth	
68-541	6"	150~365mm	85mm	20/CTN
68-542	12"	300~518mm	85mm	12/CTN
68-543	18"	450~670mm	85mm	12/CTN
68-544	24"	600~822mm	85mm	12/CTN
68-545	36"	915~1120mm	85mm	12/CTN

Aluminum Heavy Duty Bar Clamp

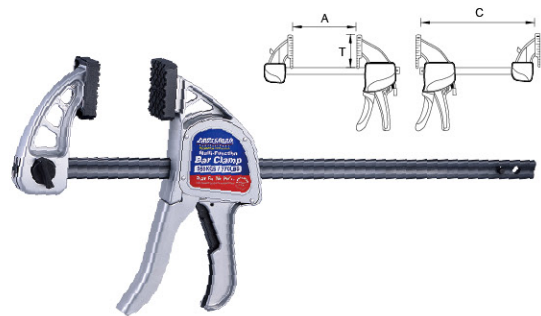

Item No.	Size(A)	Clamping Spreading	Throat depth	
68-581	6"	150~365mm	85mm	6/12
68-582	12"	300~518mm	85mm	6/12
68-583	18"	450~670mm	85mm	6/12
68-584	24"	600~822mm	85mm	6/12
68-585	36"	915~1120mm	85mm	6/12
68-586	50"	1200~1400mm	85mm	4/12

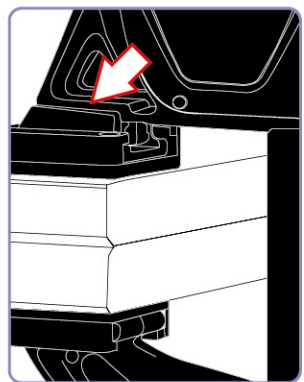
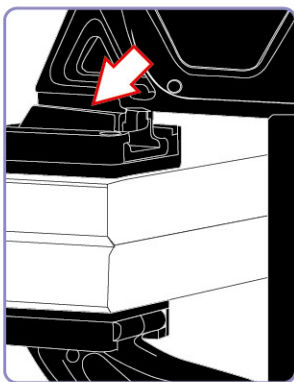

Heavy-Duty Pipe Clamp



Item No.	Throat depth	
68-538	43mm	6/12

Deep-Reach Pipe Clamp



Item No.	Throat depth	
68-539	110mm	6/12

How To Use:

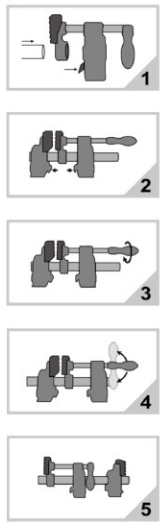

1. Press the trigger while sliding a 3/4" (27.2mm) pipe through all appointed hole.
2. Press the trigger again, then move the clamp face against the object.
3. Screw the pivot handle to make initial contact and secure the object.
4. Turn the handle into right position and continue applying pressure until desired result.
5. For spreader function, reverse clamp faces into opposite direction.

Hand Ratchet Clamp



Item No.	Throat depth	
68-571	3"	12/48



Adjustable Wrenches



Item No.	Size	
95-606	6"	6/96
95-608	8"	6/48
95-610	10"	6/36
95-612	12"	6/24
95-615	15"	1/12
95-618	18"	1/8
95-624	24"	1/4

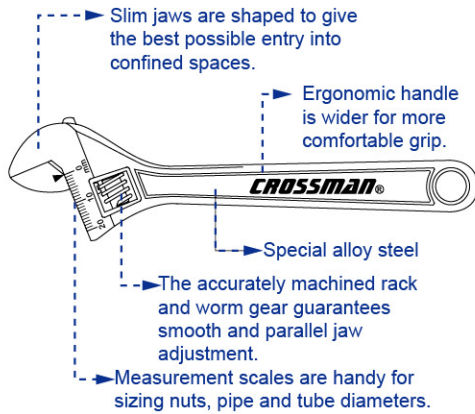

Basin Wrench



Item No.	Size	
95-901	11"	10/40

Chain Wrenches



Item No.	Size	
95-906	6"	6/36
95-909	9"	6/36
95-912	12"	6/36

Adjustable Angle Wrenches



Item No.	Size	
96-501	6"	6/96
96-502	8"	6/48
96-503	10"	6/36
96-504	12"	6/24
96-505	15"	1/16
96-506	18"	1/12
96-507	24"	1/6

Heavy Duty Pipe Wrenches



Item No.	Size	
95-708	8"	1/36
95-710	10"	1/24
95-712	12"	1/18
95-714	14"	1/12
95-718	18"	1/8
95-724	24"	1/6
95-736	36"	1/2
95-748	48"	1/2

Pipe Wrenches Aluminum Handle



Item No.	Size	
95-775	10"	1/24
95-776	12"	1/18
95-777	14"	1/12
95-779	18"	1/12
95-780	24"	1/6
95-781	36"	1/2
95-782	48"	1/2



Hand Tools

Gear Puller - 2 jaws



Item No.	Size		
82-003	3"		1/48
82-004	4"		1/24
82-006	6"		1/12
82-008	8"		1/6
82-010	10"		1/4
82-012	12"		1/2

F-Clamp

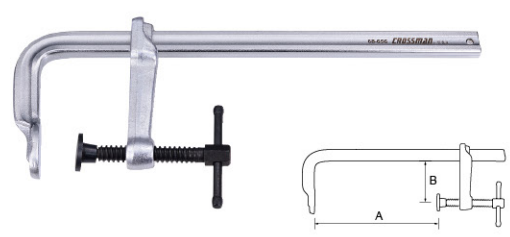

Item No.	Throat Depth (B)	Size (A)		
68-648	120 mm	8"		1/6
68-650	120 mm	10"		1/6
68-652	120 mm	12"		1/6
68-656	120 mm	16"		1/6
68-660	120 mm	20"		1/6
68-664	120 mm	24"		1/6
68-666	120 mm	36"		1/3

Oil Filter Wrench



Item No.	Size		
72-011	3"		1/36

Gear Puller - 3 jaws



Item No.	Size		
83-003	3"		1/32
83-004	4"		1/24
83-006	6"		1/6
83-008	8"		1/4
83-010	10"		1/2
83-012	12"		1/2

C-Clamp (Heavy-duty)



- High Quality Steel Screw.
- Heavy-Duty Drop Forged Steel.
- Metal-Working.

Item No.	Throat Depth (B)	Size (A)		
68-622	60 mm	2"		8/32
68-623	70 mm	3"		6/24
68-624	75 mm	4"		6/12
68-626	100 mm	6"		3/9
68-628	125 mm	8"		2/6
68-630	150 mm	10"		2/4
68-632	170 mm	12"		1/2



12Pcs. Punch Set



Item No.	84-600	1/10
----------	--------	------

Full Set Descriptions:

Item No.	Point x Hex x Length
84-701	3/32" x 1/4" x 4-1/4"
84-702	1/8" x 5/16" x 4-3/4"
84-703	5/32" x 3/8" x 5"
84-704	3/16" x 3/8" x 5-1/4"
84-705	1/4" x 7/16" x 5-3/4"
84-706	5/16" x 1/2" x 6-1/4"
84-801	3/32" x 5/16" x 5-1/2"
84-802	1/8" x 3/8" x 5-3/4"
84-803	5/32" x 3/8" x 6"
84-804	3/16" x 7/16" x 6-1/4"
84-805	1/4" x 1/2" x 6-3/4"
84-806	5/16" x 1/2" x 7-1/4"

Flaring & Tubing Cutter Tool Kits - Blue Blow Box



Item No.	95-760	1/10
----------	--------	------

- 1Pc. Flares: 1/2", 1/4", 4.75, 5, 6, 8 & 10 mm O.D.
- 1Pc. Tube Cutter: 1/8" - 1-1/8"(3 - 28mm) O.D.
- 1Pc. Steel Forged Yoke: 25/32"
- 1Pc. Swages: 1/2", 1/4", 6, 8 & 10 mm O.D.

Pin Punch



Item No.	Point x Hex x Length	1/10
84-701	3/32" x 1/4" x 4-1/4"	20/600
84-702	1/8" x 5/16" x 4-3/4"	20/600
84-703	5/32" x 3/8" x 5"	20/400
84-704	3/16" x 3/8" x 5-1/4"	20/400
84-705	1/4" x 7/16" x 5-3/4"	20/400
84-706	5/16" x 1/2" x 6-1/4"	20/200

Starting Punch (Taper Punch)



Item No.	Point x Hex x Length	1/10
84-801	3/32" x 5/16" x 5-1/2"	20/400
84-802	1/8" x 3/8" x 5-3/4"	20/400
84-803	5/32" x 3/8" x 6"	20/400
84-804	3/16" x 7/16" x 6-1/4"	20/200
84-805	1/4" x 1/2" x 6-3/4"	20/200
84-806	5/16" x 1/2" x 7-1/4"	20/200

Center Punch



Item No.	Point x Hex x Length	1/10
84-601	1/8" x 5/16" x 5"	20/400
84-602	3/16" x 7/16" x 6"	20/400

Flat Chisel (Cold Chisel)



Item No.	Point x Hex x Length	1/10
84-901	3/8" x 5/16" x 5-1/2"	20/400
84-902	1/2" x 7/16" x 6"	20/400



Hand Tools

Staple Gun

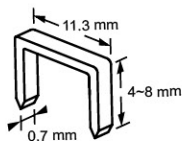

Wire: 0.7 mm
Leg Length: 4, 6, 8 mm
Crown: 10 mm Inside

Item No.	Size	
94-802	T9(JY-607A)	20/40

4-Way Staple Gun

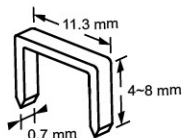

Wire: 1.2 mm
Leg Length: 6~14 mm

Item No.	
94-804	12/24

4 in 1 Staple Gun

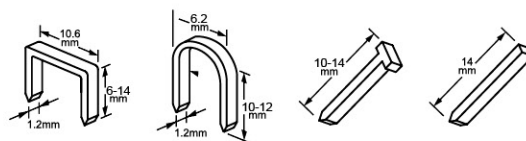

Item No.	
94-805	12/24

Hammer Staple Gun



Item No.	
94-806	10/20



Heavy-duty Hand Riveter

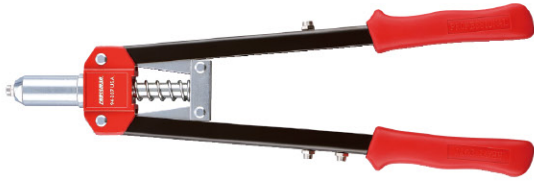

- ▶ 4 Nozzles :
2.4 mm (3/32"), 3.2mm (1/8"),
4.0 mm (5/32"), 4.8 mm (3/16")

Item No.	Size		
94-307	16"		1/12

Riveting Capacity:

	Aluminum/ Aluminium	Aluminum/ Steel	Steel/ Steel	Stainless/ Steel	Stainless/ Stainless
2.4 mm (3/32")	○	○	○	○	○
3.2mm (1/8")	○	○	○	○	○
4.0 mm (5/32")	○	○	○	○	○
4.8 mm (3/16")	○	○	○	○	×

Heavy-duty Hand Riveter



- ▶ 4 Nozzles :
3.2mm (1/8"), 4.0 mm (5/32"),
4.8 mm (3/16"), 6.4 mm (1/4")

Item No.	Size		
94-308	16"		1/12

Riveting Capacity:

	Aluminum/ Aluminium	Aluminum/ Steel	Steel/ Steel	Stainless/ Steel	Stainless/ Stainless
3.2mm (1/8")	○	○	○	○	○
4.0 mm (5/32")	○	○	○	○	○
4.8 mm (3/16")	○	○	○	○	○
6.4 mm (1/4")	○	○	○	○	×

Heavy-Duty Riveter (Steel Body)



- ▶ 4 Nozzles :
2.4 mm (3/32"), 3.2mm (1/8"),
4.0 mm (5/32"), 4.8 mm (3/16")

Item No.	Size		
94-306	10"		10/40

Heavy-Duty Riveter (Aluminum Body)



- ▶ 4 Nozzles :
2.4 mm (3/32"), 3.2mm (1/8"),
4.0 mm (5/32"), 4.8 mm (3/16")

Item No.	Size		
94-305	10"		10/40

Hand Riveter



- ▶ 4 Nozzles :
2.4 mm (3/32"), 3.2mm (1/8"),
4.0 mm (5/32"), 4.8 mm (3/16")

Item No.	Size		
94-304	10"		10/30





Hand Tools

Wood Chisel

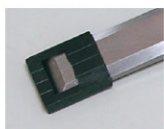

◆ Acetate handle

Item No.	Size	
67-102	1/4" (6mm)	6/60
67-103	3/8" (10mm)	6/60
67-104	1/2" (13mm)	6/60
67-105	5/8" (16mm)	6/60
67-106	3/4" (19mm)	6/60
67-107	7/8" (22mm)	6/60
67-110	1" (25mm)	6/60
67-112	1-1/4" (32mm)	6/60
67-114	1-1/2" (38mm)	6/60
67-115	2" (50mm)	6/60

Putty Knife (Scraper)



◆ Hardened stainless steel blade

Item No.	Size	
67-513	30mm	12/120
67-514	40mm	12/120
67-515	50mm	12/120
67-516	60mm	12/120
67-517	70mm	12/120
67-518	80mm	12/120
67-519	90mm	12/120
67-520	100mm	12/120
67-521	110mm	12/120
67-522	120mm	12/120
67-524	140mm	12/120
67-526	160mm	12/120

Replaceable Handle Saw



Item No.	Size	
84-731	20"	6/36
84-732	22"	6/36
84-733	24"	6/36

Hand Saw



Item No.	Size	
68-942	20"	6/36
68-943	22"	6/36
68-944	24"	6/36

HSS Bi metal Hack Saw Blade



Item No.	Size(L)	Teeth	
84-642	12"	18T	100/1000
84-643	12"	24T	100/1000
84-644	12"	32T	100/1000

Retractable Utility knife



- ◆ Spring assisted push button for quick opening.
- ◆ Self-loading design for easy replacement of fresh blades.
- ◆ Allow 8 pcs of blades max in chamber storage.

Item No.	
68-802	6/48

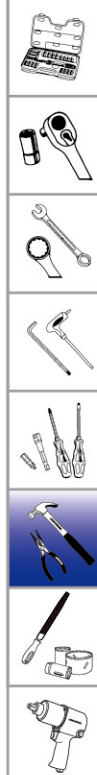

7 Pcs. Thickness Gauge



Item No.

68-557



50/400

13 Pcs. Thickness Gauge



Item No.

68-563



50/400

Measuring Tape



- ◆ ABS cover material.
- ◆ Instant stop device.

Item No.	Length	Blade Width	
68-961	3.0m/10ft	16 mm	12/144
68-963	5.0m/16ft	19 mm	12/96
* 68-964	5.0m/16ft	19 mm	12/96
68-966	5.5m/18ft	25 mm	12/72
68-967	7.5m/25ft	25 mm	12/72
68-968	8.0m/27ft	25 mm	12/72
68-969	10.0m/33ft	25 mm	12/48

* 68-964 (Chinese Letter)

Measuring Tape



- ◆ ABS cover material.

Item No.	Length	Blade Width	
68-901	3.6m/12ft	13 mm	12/120
* 68-900	5.0m/16ft	19 mm	12/120
68-903	5.5m/18ft	19 mm	12/120
68-904	5.5m/18ft	25 mm	12/120
68-905	7.5m/25ft	25 mm	12/72

* 68-900 (Chinese Letter)

Angle Finder

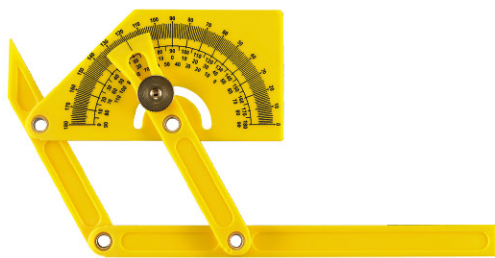

- ◆ Made of impact resistant material.
- ◆ Both interior & exterior 0° to 180° angle readout.
- ◆ Durable brass bolt & nut are included.

Item No.

68-980



6/54



Hand Tools

Spirit level with Magnetic Base



Item No.	Size		
68-921	15 cm/6"	1/120	
68-922	30 cm/12"	1/60	
68-923	40 cm/16"	1/60	
94-118	50 cm/20"	1/60	
68-924	60 cm/24"	1/50	
68-925	80 cm/32"	1/50	
68-926	120 cm/48"	1/30	

Magnetic Billet Torpedo Level



- ◆ Solid aluminum body frame w/copper bolt
- ◆ 4 bubble-free reading vials at 0°, 30°, 45°, 90°
- ◆ Powerful rare earth magnets.

Item No.	Size		
68-598	6"	6/48	

Magnetic Billet Torpedo Level



- ◆ Solid aluminum body frame.
- ◆ 4 bubble-free reading vials at 0°, 30°, 45°, 90°
- ◆ Powerful rare earth magnets.

Item No.	Size		
68-599	8"	6/48	

Grease Gun



Item No.	Size		
70-604	400c.c.	1/10	

Air Grease Gun



Item No.	Size		
70-504	400c.c.	1/6	

Spray Gun



HVLP Type			
Item No.	Nozzle Dia	With Cup	
70-780	1.3 mm	400c.c.	1/10
70-781	1.5 mm	400c.c.	1/10
70-782	1.7 mm	400c.c.	1/10
70-783	2.0 mm	400c.c.	1/10

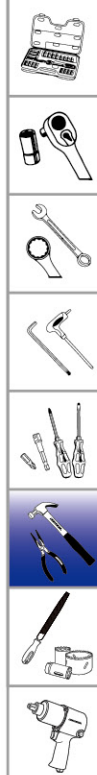

Spray Gun



400c.c. 700c.c. 1000c.c.

Gravity Type

Item No.	Nozzle Dia	With Cup	 
70-720	0.8 mm	400c.c.	1/10
70-721	1.1 mm	400c.c.	1/10
70-722	1.3 mm	400c.c.	1/10
70-723	1.4 mm	400c.c.	1/10
70-724	1.5 mm	400c.c.	1/10
70-725	1.8 mm	400c.c.	1/10
70-726	2.0 mm	400c.c.	1/10
70-727	2.5 mm	400c.c.	1/10
70-728	3.0 mm	400c.c.	1/10

Suction Type

Item No.	Nozzle Dia	With Cup	 
70-730	0.8 mm	700c.c.	1/10
70-731	1.1 mm	700c.c.	1/10
70-732	1.3 mm	700c.c.	1/10
70-733	1.4 mm	700c.c.	1/10
70-734	1.5 mm	700c.c.	1/10
70-735	1.8 mm	700c.c.	1/10
70-736	2.0 mm	700c.c.	1/10
70-737	2.5 mm	700c.c.	1/10
70-738	3.0 mm	700c.c.	1/10
70-740	0.8 mm	1000c.c.	1/10
70-741	1.1 mm	1000c.c.	1/10
70-742	1.3 mm	1000c.c.	1/10
70-743	1.4 mm	1000c.c.	1/10
70-744	1.5 mm	1000c.c.	1/10
70-745	1.8 mm	1000c.c.	1/10
70-746	2.0 mm	1000c.c.	1/10
70-747	2.5 mm	1000c.c.	1/10
70-748	3.0 mm	1000c.c.	1/10

Spray Gun



400c.c. 700c.c. 1000c.c.

Gravity Type

Item No.	Nozzle Dia	With Cup	 
70-750	0.8 mm	400c.c.	1/10
70-751	1.0 mm	400c.c.	1/10
70-752	1.3 mm	400c.c.	1/10
70-753	1.5 mm	400c.c.	1/10
70-754	1.8 mm	400c.c.	1/10
70-755	2.0 mm	400c.c.	1/10

Suction Type

Item No.	Nozzle Dia	With Cup	 
70-760	0.8 mm	700c.c.	1/10
70-761	1.0 mm	700c.c.	1/10
70-762	1.3 mm	700c.c.	1/10
70-763	1.5 mm	700c.c.	1/10
70-764	1.8 mm	700c.c.	1/10
70-765	2.0 mm	700c.c.	1/10
70-770	0.8 mm	1000c.c.	1/10
70-771	1.0 mm	1000c.c.	1/10
70-772	1.3 mm	1000c.c.	1/10
70-773	1.5 mm	1000c.c.	1/10
70-774	1.8 mm	1000c.c.	1/10
70-775	2.0 mm	1000c.c.	1/10



Tool Boxes / Roller Cabinet

7 Drawer Roll Wagon / Ball Bearing Slider



Item No.	Size			kgs
90-531	670 x 460 x 812mm	1		72kgs

Workbench equipped with a hanging board



Item No.	Size			kgs
90-533	1525 x 700 x 1520mm	1		62kgs

3 Shelf Trolley w/ 3 drawers



Item No.	Size			kgs
90-535	716 x 410 x 750 mm	1		35kgs

Tool Box



Item No.	Cuft		kgs
90-021	0.88		4.0kg
Type	W	D	H
Overall	482	180	190

7 Drawer Roll Wagon



Item No.	Size			kgs
90-532	1070 x 460 x 980mm	1		139kgs

3 Shelf Trolley



Item No.	Size			kgs
90-534	716 x 41 x 750mm	1		22kgs

6 Drawer Top Chest / Ball Bearing Slider



Item No.	Size			kgs
90-530	660 x 307 x 374 mm	1		27kgs



FILES



P164 Mill File

P164 Flat File

P165 Half Round File

P165 Round File

P166 Three Square File



File Terminology

American Pattern



- Work to be accomplished, roughing or finishing, will determine type of teeth and coarseness for each application.
- Most American pattern files are available with 3 grades of cut: bastard-cut, second-cut and smooth-cut.
- The degree of coarseness is greater in longer files, but differences between bastard, second and smooth are proportionate.

Length

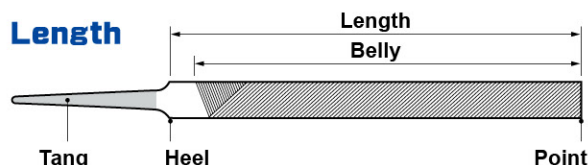

- Length is measured exclusive of tang, from point to heel, unless specified otherwise.
- Desired stroke length, type of material and size will determine length required.

Shape

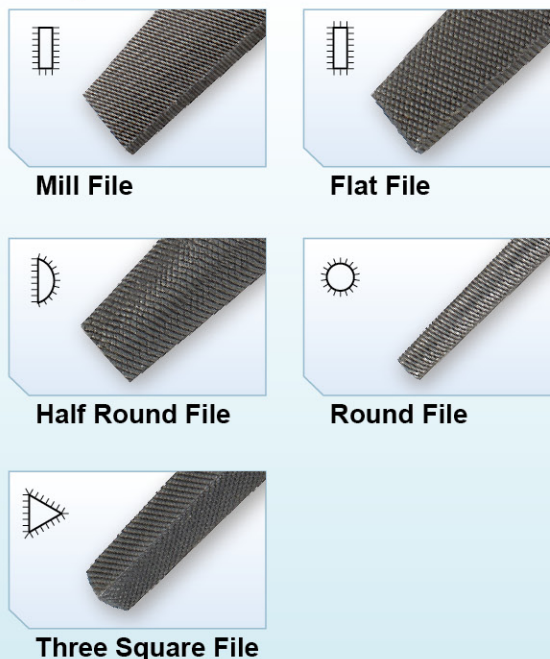

Kinds of Teeth



Single-cut

- Single set of parallel, diagonal rows of teeth.
- Single-cut files are often used with light pressure to produce a smooth surface finish or to put a keen edge on knives, shears or saws.



Double-cut

- 2 sets of diagonal rows of teeth.
- Second set of teeth cut in opposite diagonal direction and on top of the first set.
- First set of teeth is known as the overcut, second is known as upcut.
- Upcut is finer than overcut.
- Double-cut file is used with heavier pressure than the single-cut and removes material faster from the workpiece.

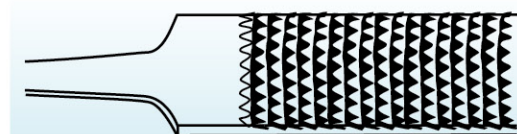

Rasp-cut

- Series of individual teeth which are formed by a single-pointed tool.
- Produces a rough cut that is used primarily on wood, hooves, aluminum and lead.

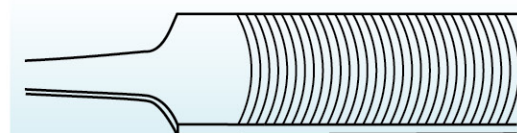

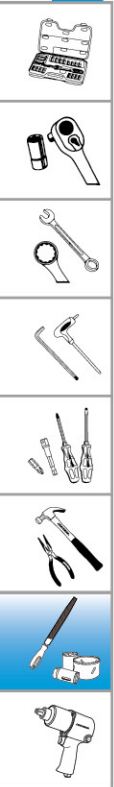

Curved-cut

- Teeth arranged in curved contours across the file face.
- Curved-cut file is normally used in automotive body shops for smoothing body panels.



Mill Files



Mill File

Item No.	Size		 kgs
Fine (Smooth Cut)			
84-121	4"	10/240	0.3/10.0
84-122	6"	10/180	0.6/13.0
84-123	8"	10/120	1.2/13.0
84-124	10"	12/72	3.0/19.0
84-125	12"	6/36	4.0/17.0

- Used for sharpening mill or circular saws.
- Single-cut on sides and edges.

Flat Files

Flat File

Item No.	Size		 kgs
Rough (Bastard Cut)			
84-201	4"	10/240	0.3/10.0
84-202	6"	10/180	0.6/13.0
84-203	8"	10/120	1.2/13.0
84-204	10"	12/72	2.3/14.5
84-205	12"	6/36	2.5/11.0
84-206	14"	6/24	3.7/16.0
Middle (Second Cut)			
84-211	4"	10/240	0.3/10.0
84-212	6"	10/180	0.6/13.0
84-213	8"	10/120	1.2/13.0
84-214	10"	12/72	2.3/14.5
84-215	12"	6/36	2.5/11.0
84-216	14"	6/24	3.7/16.0
Fine (Smooth Cut)			
84-221	4"	10/240	0.3/10.0
84-222	6"	10/180	0.6/13.0
84-223	8"	10/120	1.2/13.0
84-224	10"	12/72	2.3/14.5
84-225	12"	6/36	2.5/11.0
84-226	14"	6/24	3.7/16.0

- Double-cut on sides, single-cut on edges.
- Rectangular in cross section, taper slightly towards point in width.



Half Round Files

Half Round File



Item No.	Size		kgs
Rough (Bastard Cut)			
84-301	4"	10/240	0.4/13.0
84-302	6"	10/180	0.8/17.0
84-303	8"	10/120	1.5/16.0
84-304	10"	12/72	2.4/15.0
84-305	12"	6/36	2.5/10.0
84-306	14"	6/24	3.7/15.0
Middle (Second Cut)			
84-311	4"	10/240	0.4/13.0
84-312	6"	10/180	0.8/17.0
84-313	8"	10/120	1.5/16.0
84-314	10"	12/72	2.4/15.0
84-315	12"	6/36	2.5/10.0
84-316	14"	6/24	3.7/15.0
Fine (Smooth Cut)			
84-321	4"	10/240	0.4/13.0
84-322	6"	10/180	0.8/17.0
84-323	8"	10/120	1.5/16.0
84-324	10"	12/72	2.4/15.0
84-325	12"	6/36	2.5/10.0
84-326	14"	6/24	3.7/15.0

- Round on one side, flat on opposite.
- Use on concave, convex and flat surfaces.

Round Files

Round File





Item No.	Size		kgs
Rough (Bastard Cut)			
84-401	4"	10/240	0.2/5.5
84-402	6"	10/180	0.3/6.5
84-403	8"	10/120	0.7/8.2
84-404	10"	12/72	1.2/8.2
84-405	12"	6/36	1.2/6.0
84-406	14"	6/24	1.8/8.2
Middle (Second Cut)			
84-411	4"	10/240	0.2/5.5
84-412	6"	10/180	0.3/6.5
84-413	8"	10/120	0.7/8.2
84-414	10"	12/72	1.2/8.2
84-415	12"	6/36	1.2/6.0
84-416	14"	6/24	1.8/8.2
Fine (Smooth Cut)			
84-421	4"	10/240	0.2/5.5
84-422	6"	10/180	0.3/6.5
84-423	8"	10/120	0.7/8.2
84-424	10"	12/72	1.2/8.2
84-425	12"	6/36	1.2/6.0
84-426	14"	6/24	1.8/8.2

- Round cross section, single-cut (except for 14" bastard) and slightly tapered towards point.
- Primarily used to file circular openings or concave surfaces.

Three Square Files

■ Three Square File

Item No.	Size		 kgs
Rough (Bastard Cut)			
84-501	4"	10/240	0.2/7.5
84-502	6"	10/180	0.6/13.0
84-503	8"	10/120	1.2/13.0
84-504	10"	12/72	2.3/15.0
84-505	12"	6/36	2.5/11.0
84-506	14"	6/24	3.7/16.0
Middle (Second Cut)			
84-511	4"	10/240	0.2/7.5
84-512	6"	10/180	0.6/13.0
84-513	8"	10/120	1.2/13.0
84-514	10"	12/72	2.3/15.0
84-515	12"	6/36	2.5/11.0
84-516	14"	6/24	3.7/16.0
Fine (Smooth Cut)			
84-521	4"	10/240	0.2/7.5
84-522	6"	10/180	0.6/13.0
84-523	8"	10/120	1.2/13.0
84-524	10"	12/72	2.3/15.0
84-525	12"	6/36	2.5/11.0
84-526	14"	6/24	3.7/16.0

- Single-cut.
- Made for filing saws with 60° angle teeth, axes and machetes.



← If plastic handle were needed, please add additional "PH" to the item number.

For Example

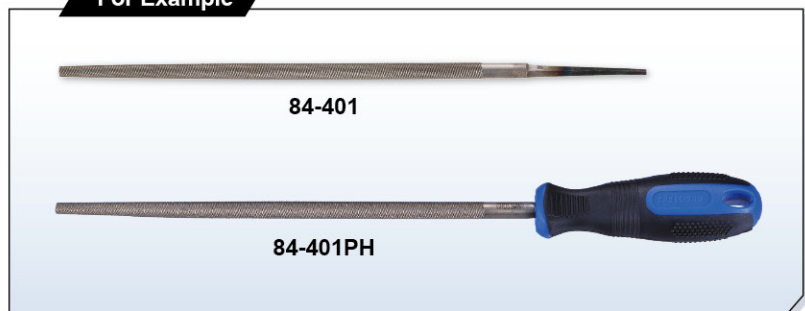

HOLE SAWS



P168 Hole Saws

P169 Hole Saws Arbor



Hole Saws

Hole Saw



Item No.	Diameter mm	Diameter inch		 kgs
84-001	14 mm	9/16"	1/60	0.02/1.2
84-002	16 mm	5/8"	1/60	0.04/2.4
84-003	17 mm	11/16"	1/60	0.04/2.4
84-004	19 mm	3/4"	1/60	0.05/2.8
84-005	20 mm	25/32"	1/60	0.05/2.8
84-006	21 mm	13/16"	1/60	0.05/3.0
84-007	22 mm	7/8"	1/60	0.05/3.2
84-008	24 mm	15/16"	1/60	0.06/3.8
84-009	25 mm	1"	1/60	0.07/4.2
84-010	27 mm	1-1/16"	1/60	0.08/4.6
84-011	29 mm	1-1/8"	1/60	0.09/5.2
84-012	30 mm	1-3/16"	1/60	0.09/5.5

Hole Saw



Item No.	Diameter mm	Diameter inch		 kgs
84-013	32 mm	1-1/4"	1/60	0.09/5.2
84-014	33 mm	1-5/16"	1/60	0.09/5.5
84-015	35 mm	1-3/8"	1/60	0.10/6.0
84-016	37 mm	1-7/16"	1/60	0.10/6.1
84-017	38 mm	1-1/2"	1/60	0.10/6.2
84-018	40 mm	1-9/16"	1/60	0.10/6.2
84-019	41 mm	1-5/8"	1/60	0.11/6.3
84-020	43 mm	1-11/16"	1/60	0.11/6.4
84-021	44 mm	1-3/4"	1/60	0.11/6.4
84-022	46 mm	1-13/16"	1/60	0.12/7.0
84-023	48 mm	1-7/8"	1/60	0.12/7.3
84-024	51 mm	2"	1/60	0.14/8.2
84-025	52 mm	2-1/16"	1/60	0.14/8.2
84-026	54 mm	2-1/8"	1/60	0.14/8.5
84-027	57 mm	2-1/4"	1/60	0.16/9.8
84-028	59 mm	2-5/16"	1/60	0.17/10.0
84-029	60 mm	2-3/8"	1/60	0.18/10.6
84-030	64 mm	2-1/2"	1/60	0.19/11.2
84-031	65 mm	2-9/16"	1/60	0.20/11.8
84-032	67 mm	2-5/8"	1/60	0.21/12.4
84-033	70 mm	2-3/4"	1/60	0.23/13.6
84-034	73 mm	2-7/8"	1/60	0.24/14.2
84-035	76 mm	3"	1/60	0.26/15.4
84-036	79 mm	3-1/8"	1/60	0.27/16.0
84-037	83 mm	3-1/4"	1/60	0.30/16.6
84-038	86 mm	3-3/8"	1/60	0.34/17.8
84-039	89 mm	3-1/2"	1/24	0.36/8.2
84-040	92 mm	3-5/8"	1/24	0.36/8.7



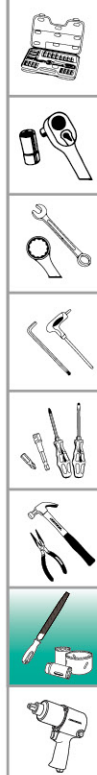











Hole Saws

Hole Saw



Item No.	Diameter mm	Diameter inch		 kgs
84-041	95 mm	3-3/4"	1/24	0.36/8.7
84-042	98 mm	3-7/8"	1/24	0.43/10.2
84-043	102 mm	4"	1/24	0.48/11.4
84-044	105 mm	4-1/8"	1/24	0.48/11.4
84-045	108 mm	4-1/4"	1/24	0.48/11.6
84-046	111 mm	4-3/8"	1/24	0.5/12.05
84-047	114 mm	4-1/2"	1/24	0.52/12.5
84-048	121 mm	4-3/4"	1/24	0.60/14.9
84-049	127 mm	5"	1/24	0.64/15.4
84-050	133 mm	5-1/4"	1/12	0.77/9.2
84-051	140 mm	5-1/2"	1/12	0.89/10.7
84-052	152 mm	6"	1/12	0.93/11.1



Applications

Metals 	INOX Stainless Steel 	Cast Iron 	Brass, Copper 	Zamak 
Aluminium 	Antimonium 	Wood 	Bakelite 	Plastic 

Hole Saw Arbors

Hole Saw Arbor



Item No.	Fits Chuck Size		Fits Hole Saw Diameter			 kgs
	mm	inch	mm	inch		
84-100	6.35	1/4"	14~30	Ø9/16"~1-3/16"	1/60	0.09/5.2

Hole Saw Arbor



Item No.	Fits Chuck Size		Fits Hole Saw Diameter			 kgs
	mm	inch	mm	inch		
84-200	9.5	3/8"	32~152	Ø1-1/4"~6"	1/60	0.23/14.2

● Quick-lock type.

PNEUMATIC TOOLS



P171 Air Impact Wrenches

P175 Air Ratchet Wrenches

P180 Air Screwdrivers & Air Riveters

P181 Air Nibblers & Angle Grinders

P182 Random Orbital Sanders

P183 Air Tools

P187 Air Impact Wrench Sets

Air Impact Wrench Features

Hammer Mechanism

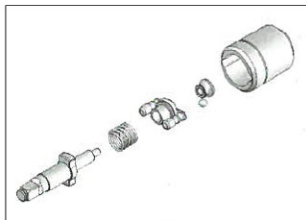
**Pin Clutch****Mechanism:**

- Smooth balance impact for operation.
- Provided with high torque and durability.
- Low vibration and noise.
- Smooth bolt starting excellent for use in industry assembly line applications.

**Pin Less****Mechanism:**

- Closet hammer cage mechanism prevents breakage from hammer pin damage.
- Special extension design of hammer cam provides smooth balance impact, low vibration level and high torque level.
- Undivided hammer pin and hammer dog mechanism prevent damage of hammer pin, increased tools lifetime.
- Simple mechanism easy for tools maintenance.

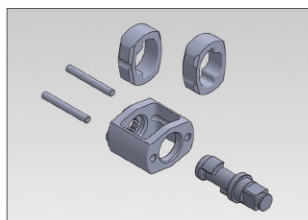
**Twin Hammer****Mechanism:**

- Two identical hammers provided with instantaneous balance blow and highest torque for blow starting.
- Durable hammer design and excellent for use in heavy-duty industrial applications.
- Simple mechanism easy for tools maintenance.

**Rocking Dog****Mechanism:**

- Simple design hammer mechanism provided great hitting power, easy maintenance.
- Simple design recommended for medium duty industrial applications.



Air Impact Wrench



Twin Hammer

7"

- For spring work, tractor pads, truck maintenance, off-road and farm equipment work.

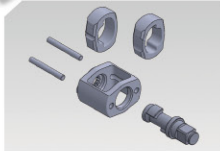

SPECIFICATION

Item No.		71-809
Square Drive		1"
Clutch Mechanism		Twin Hammer
Bolt Capacity		2" (50 mm)
Max Torque		2,500 FT-LB
Free Speed		3,000 R.P.M
Air Consumption		8.5 CFM
Air Inlet		1/2"
Air Pressure		90 Psi
Overall Length		453 mm
Air Hose		1/2" (13 mm)
Packing		1/1

Air Impact Wrench



Pin Less

7"

- For spring work, tractor pads, truck maintenance, off-road and farm equipment work.



SPECIFICATION

Item No.		71-808
Square Drive		1"
Clutch Mechanism		Pin Less
Bolt Capacity		2" (50 mm)
Max Torque		2,500 FT-LB
Free Speed		3,000 R.P.M
Air Consumption		8.5 CFM
Air Inlet		1/2"
Air Pressure		90 Psi
Overall Length		443 mm
Air Hose		1/2" (13 mm)
Packing		1/1

Air Impact Wrench



Twin Hammer

3/4"

SPECIFICATION

Item No.		71-815
Square Drive		3/4"
Clutch Mechanism		Twin Hammer
Bolt Capacity		1-1/8" (28 mm)
Max Torque		1,200 FT-LB
Free Speed		5,500 R.P.M
Air Consumption		7 CFM
Air Inlet		3/8"
Air Pressure		90 Psi
Overall Length		221 mm
Air Hose		1/2" (13 mm)
Packing		1/4

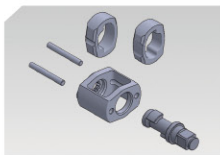

Air Impact Wrench



Twin Hammer

1/2"

SPECIFICATION

Item No.		71-816
Square Drive		1/2"
Clutch Mechanism		Twin Hammer
Bolt Capacity		5/8" (16 mm)
Max Torque		1,000 FT-LB
Free Speed		10,000 R.P.M
Air Consumption		5.4 CFM
Air Inlet		1/4"
Air Pressure		90 Psi
Overall Length		193 mm
Air Hose		3/8" (10 mm)
Packing		1/10

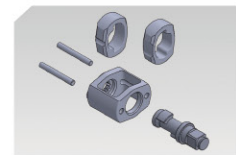

Pneumatic Tools

Air Impact Wrench



Twin Hammer

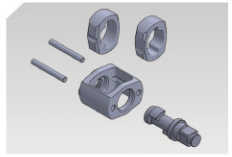

SPECIFICATION

Item No.		71-810
Square Drive		1/2"
Clutch Mechanism		Twin Hammer
Bolt Capacity		5/8" (16 mm)
Max Torque		500 FT-LB
Free Speed		10,000 R.P.M
Air Consumption		6.2 CFM
Air Inlet		1/4"
Air Pressure		90 Psi
Overall Length		122 mm
Air Hose		3/8" (10 mm)
Packing		1/10

Air Impact Wrench



Rocking Dog

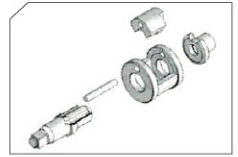

SPECIFICATION

Item No.		71-804
Square Drive		1/2"
Clutch Mechanism		Rocking Dog
Bolt Capacity		5/8" (16 mm)
Max Torque		250 FT-LB
Free Speed		7,000 R.P.M
Air Consumption		10.6 CFM
Air Inlet		1/4"
Air Pressure		90 Psi
Overall Length		190 mm
Air Hose		3/8" (10 mm)
Packing		1/10

Air Impact Wrench



Pin Clutch

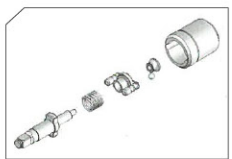

SPECIFICATION

Item No.		71-801
Square Drive		3/8"
Clutch Mechanism		Pin Clutch
Bolt Capacity		1/2" (13 mm)
Max Torque		160 FT-LB
Free Speed		10,000 R.P.M
Air Consumption		9.5 CFM
Air Inlet		1/4"
Air Pressure		90 Psi
Overall Length		163 mm
Air Hose		3/8" (10 mm)
Packing		1/10

Air Impact Wrench



Pin Clutch

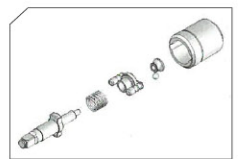

SPECIFICATION

Item No.		71-803
Square Drive		1/2"
Clutch Mechanism		Pin Clutch
Bolt Capacity		5/8" (16 mm)
Max Torque		400 FT-LB
Free Speed		7,000 R.P.M
Air Consumption		10.6 CFM
Air Inlet		1/4"
Air Pressure		90 Psi
Overall Length		197 mm
Air Hose		3/8" (10 mm)
Packing		1/10



Air Ratchet Wrench



Twin Hammer

7"

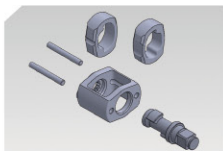

SPECIFICATION

Item No.		71-813
Square Drive		1"
Clutch Mechanism		Twin Hammer
Bolt Capacity		1-7/16" (36 mm)
Max Torque		1,600 FT-LB
Free Speed		8,000 R.P.M
Air Consumption		6.3 CFM
Air Inlet		3/8"
Air Pressure		90 Psi
Overall Length		209mm
Air Hose		3/8" (10 mm)
Packing		1/4

Air Ratchet Wrench



Twin Hammer

3/4"

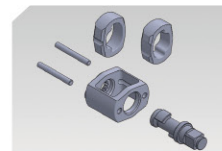

SPECIFICATION

Item No.		71-814
Square Drive		3/4"
Clutch Mechanism		Twin Hammer
Bolt Capacity		1-5/16" (32 mm)
Max Torque		1,500 FT-LB
Free Speed		8,000 R.P.M
Air Consumption		6.3 CFM
Air Inlet		3/8"
Air Pressure		90 Psi
Overall Length		209 mm
Air Hose		3/8" (10 mm)
Packing		1/4

Air Impact Wrench



Twin Hammer

1/2"

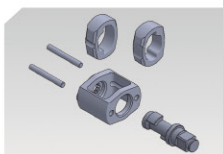

SPECIFICATION

Item No.		71-821
Square Drive		1/2"
Clutch Mechanism		Twin Hammer
Bolt Capacity		13/16" (21 mm)
Max Torque		1,000 FT-LB
Free Speed		10,000 R.P.M
Air Consumption		5.1 CFM
Air Inlet		1/4"
Air Pressure		90 Psi
Overall Length		126 mm
Air Hose		3/8" (10 mm)
Packing		1/10

Air Impact Wrench



Twin Hammer

1/2"

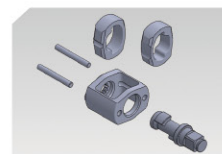

SPECIFICATION

Item No.		71-820
Square Drive		1/2"
Clutch Mechanism		Twin Hammer
Bolt Capacity		9/16" (14 mm)
Max Torque		500 FT-LB
Free Speed		10,000 R.P.M
Air Consumption		6.2 CFM
Air Inlet		1/4"
Air Pressure		90 Psi
Overall Length		98 mm
Air Hose		3/8" (10 mm)
Packing		1/10



Pneumatic Tools

Air Ratchet Wrench

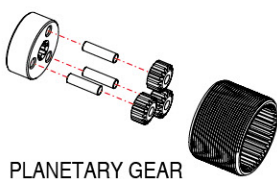

PLANETARY GEAR

SPECIFICATION

Item No.	Square Drive inch	Bolt Size inch (mm)	Max Torque FT-LB/N-m	Free Speed RPM	Air Consumption CFM	Air Inlet	Air Pressure psi	Overall Length mm	Air Hose inch (mm)	Packing
71-830	3/8"	3/8" (10)	20/27	520	2.6	1/4"	90	120	3/8" (10)	1/25
71-833	1/4"	5/16" (8)	20/27	520	2.6	1/4"	90	120	3/8" (10)	1/25
71-835	3/8"	3/8" (10)	20/27	520	2.6	1/4"	90	130	3/8" (10)	1/25
71-838	1/4"	5/16" (8)	20/27	520	2.6	1/4"	90	130	3/8" (10)	1/25

Air Ratchet Wrench

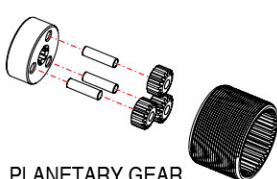

PLANETARY GEAR



360° ROTATION



LOCKED

SPECIFICATION

Item No.	Square Drive inch	Bolt Size inch (mm)	Max Torque FT-LB/N-m	Free Speed RPM	Air Consumption CFM	Air Inlet	Air Pressure psi	Overall Length mm	Air Hose inch (mm)	Packing
71-831	3/8" (15° universal)	3/8" (10)	20/27	520	2.6	1/4"	90	120	3/8" (10)	1/25
71-836	3/8" (15° universal)	3/8" (10)	20/27	520	2.6	1/4"	90	130	3/8" (10)	1/25

Air Ratchet Wrench

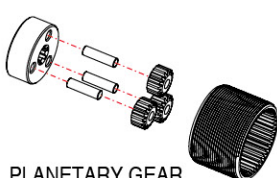

PLANETARY GEAR

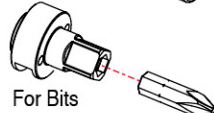
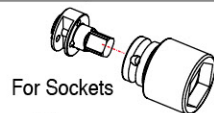

For Sockets

For Bits



SPECIFICATION

Item No.	Square Drive inch	Bolt Size inch (mm)	Max Torque FT-LB/N-m	Free Speed RPM	Air Consumption CFM	Air Inlet	Air Pressure psi	Overall Length mm	Air Hose inch (mm)	Packing
71-832	3/8" (Socket & Bits)	3/8" (10)	20/27	520	2.6	1/4"	90	120	3/8" (10)	1/25
71-837	3/8" (Socket & Bits)	3/8" (10)	20/27	520	2.6	1/4"	90	130	3/8" (10)	1/25



Air Ratchet Wrench

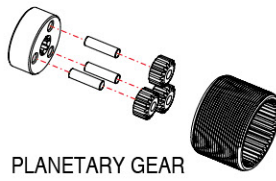

PLANETARY GEAR

SPECIFICATION

Item No.	Square Drive inch	Bolt Size inch (mm)	Max Torque FT-LB/N-m	Free Speed RPM	Air Consumption CFM	Air Inlet	Air Pressure psi	Overall Length mm	Air Hose inch (mm)	Packing
71-840	3/8"	3/8" (10)	25/34	350	2.6	1/4"	90	165	3/8" (10)	1/20
71-843	1/4"	5/16" (8)	25/34	350	2.6	1/4"	90	165	3/8" (10)	1/20

Air Ratchet Wrench

15 Degree Universal

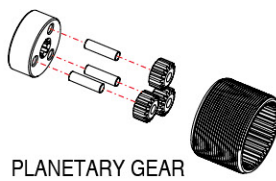

PLANETARY GEAR

Wobble Head



360° ROTATION

LOCKED

SPECIFICATION

Item No.	Square Drive inch	Bolt Size inch (mm)	Max Torque FT-LB/N-m	Free Speed RPM	Air Consumption CFM	Air Inlet	Air Pressure psi	Overall Length mm	Air Hose inch (mm)	Packing
71-841	3/8" (15° universal)	3/8" (10)	25/34	350	2.6	1/4"	90	165	3/8" (10)	1/20

Air Ratchet Wrench

Socket & Bits

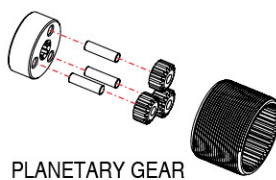

PLANETARY GEAR

Dual Purpose Anvil Assembly

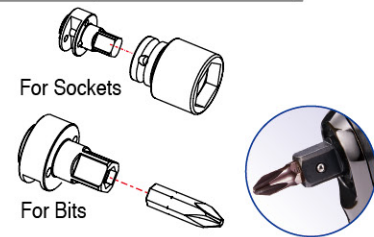

For Sockets

For Bits

SPECIFICATION

Item No.	Square Drive inch	Bolt Size inch (mm)	Max Torque FT-LB/N-m	Free Speed RPM	Air Consumption CFM	Air Inlet	Air Pressure psi	Overall Length mm	Air Hose inch (mm)	Packing
71-842	3/8" (Socket & Bits)	3/8" (10)	25/34	350	2.6	1/4"	90	165	3/8" (10)	1/20



Pneumatic Tools

Air Ratchet Wrench

PLANETARY GEAR

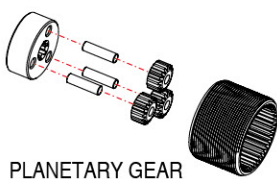

PLANETARY GEAR

SPECIFICATION

Item No.	Square Drive inch	Bolt Size inch (mm)	Max Torque FT-LB/N-m	Free Speed RPM	Air Consumption CFM	Air Inlet	Air Pressure psi	Overall Length mm	Air Hose inch (mm)	Packing
71-855	1/2"	1/2" (13)	70/95	350	3.8	1/4"	90	240	3/8" (10)	1/20
71-858	3/8"	3/8" (10)	70/95	350	3.8	1/4"	90	240	3/8" (10)	1/20

Air Ratchet Wrench

15 Degree Universal

PLANETARY GEAR

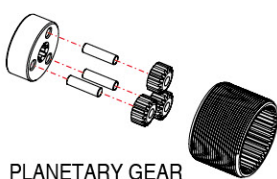

PLANETARY GEAR

Wobble Head



360° ROTATION

LOCKED

SPECIFICATION

Item No.	Square Drive inch	Bolt Size inch (mm)	Max Torque FT-LB/N-m	Free Speed RPM	Air Consumption CFM	Air Inlet	Air Pressure psi	Overall Length mm	Air Hose inch (mm)	Packing
71-856	1/2" (15° universal)	1/2" (13)	70/95	350	3.8	1/4"	90	240	3/8" (10)	1/20

Air Ratchet Wrench

Socket & Bits

PLANETARY GEAR

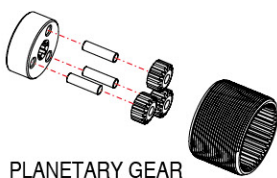

PLANETARY GEAR

Dual Purpose Anvil Assembly

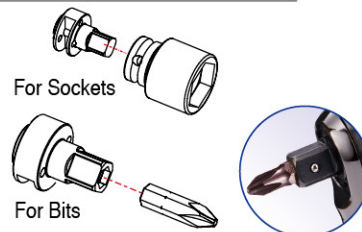

For Sockets

For Bits

SPECIFICATION

Item No.	Square Drive inch	Bolt Size inch (mm)	Max Torque FT-LB/N-m	Free Speed RPM	Air Consumption CFM	Air Inlet	Air Pressure psi	Overall Length mm	Air Hose inch (mm)	Packing
71-857	1/2" (Socket & Bits)	1/2" (13)	70/95	350	3.8	1/4"	90	240	3/8" (10)	1/20

Pneumatic Tools

Air Ratchet Wrench

PLANETARY GEAR



SPECIFICATION

Item No.	Square Drive inch	Bolt Size inch (mm)	Max Torque FT-LB/N-m	Free Speed RPM	Air Consumption CFM	Air Inlet	Air Pressure psi	Overall Length mm	Air Hose inch (mm)	Packing
71-845	1/2"	1/2" (13)	65/88	320	3.5	1/4"	90	260	3/8" (10)	1/20
71-848	3/8"	3/8" (10)	65/88	320	3.5	1/4"	90	260	3/8" (10)	1/20
71-850	1/2"	1/2" (13)	65/88	320	3.5	1/4"	90	240	3/8" (10)	1/20
71-853	3/8"	3/8" (10)	65/88	320	3.5	1/4"	90	240	3/8" (10)	1/20

Air Ratchet Wrench

15 Degree Universal

PLANETARY GEAR



Wobble Head

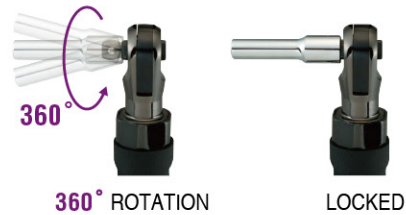

SPECIFICATION

Item No.	Square Drive inch	Bolt Size inch (mm)	Max Torque FT-LB/N-m	Free Speed RPM	Air Consumption CFM	Air Inlet	Air Pressure psi	Overall Length mm	Air Hose inch (mm)	Packing
71-846	1/2" (15° universal)	1/2" (13)	65/88	320	3.5	1/4"	90	260	3/8" (10)	1/20
71-851	1/2" (15° universal)	1/2" (13)	65/88	320	3.5	1/4"	90	240	3/8" (10)	1/20

Air Ratchet Wrench

Socket & Bits

PLANETARY GEAR



Dual Purpose Anvil Assembly

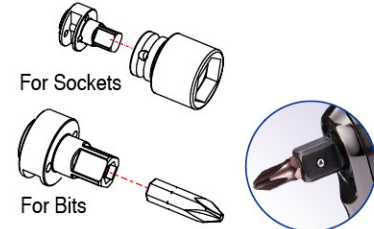

SPECIFICATION

Item No.	Square Drive inch	Bolt Size inch (mm)	Max Torque FT-LB/N-m	Free Speed RPM	Air Consumption CFM	Air Inlet	Air Pressure psi	Overall Length mm	Air Hose inch (mm)	Packing
71-847	1/2" (Socket & Bits)	1/2" (13)	65/88	320	3.5	1/4"	90	260	3/8" (10)	1/20
71-852	1/2" (Socket & Bits)	1/2" (13)	65/88	320	3.5	1/4"	90	240	3/8" (10)	1/20

Pneumatic Tools

Air Ratchet Wrench **FULL RANGE GEAR**

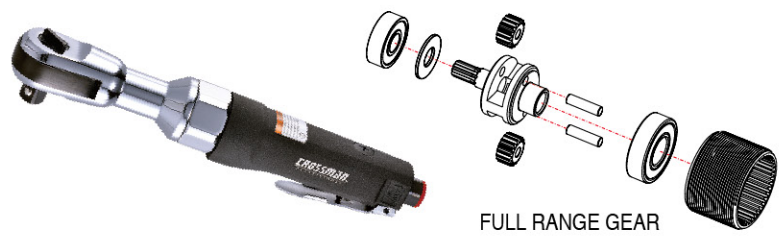

SPECIFICATION

Item No.	Square Drive inch	Bolt Size inch (mm)	Max Torque FT-LB/N-m	Free Speed RPM	Air Consumption CFM	Air Inlet	Air Pressure psi	Overall Length mm	Air Hose inch (mm)	Packing
71-860	1/2"	1/2" (13)	70/95	320	3.5	1/4"	90	260	3/8" (10)	1/20
71-863	3/8"	3/8" (10)	70/95	320	3.5	1/4"	90	260	3/8" (10)	1/20

Air Ratchet Wrench **15 Degree Universal** **FULL RANGE GEAR**

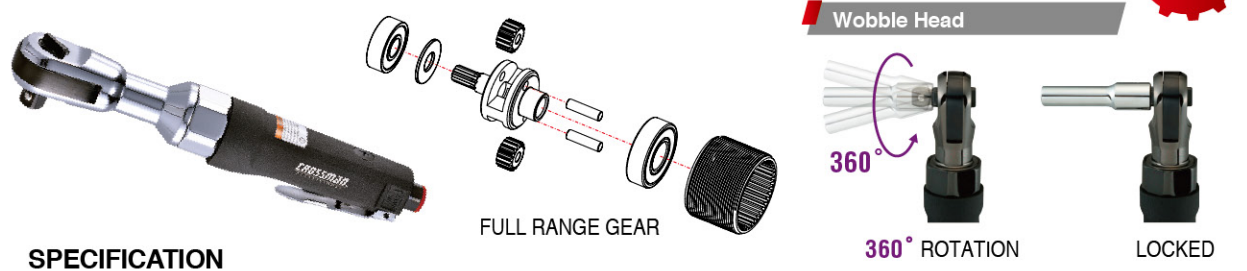

SPECIFICATION

Item No.	Square Drive inch	Bolt Size inch (mm)	Max Torque FT-LB/N-m	Free Speed RPM	Air Consumption CFM	Air Inlet	Air Pressure psi	Overall Length mm	Air Hose inch (mm)	Packing
71-861	1/2" (15° universal)	1/2" (13)	70/95	320	3.5	1/4"	90	260	3/8" (10)	1/20

Air Ratchet Wrench **Socket & Bits** **FULL RANGE GEAR**

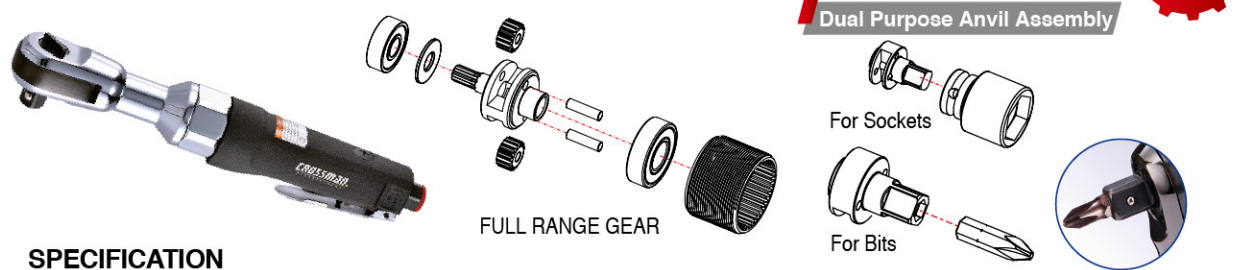

SPECIFICATION

Item No.	Square Drive inch	Bolt Size inch (mm)	Max Torque FT-LB/N-m	Free Speed RPM	Air Consumption CFM	Air Inlet	Air Pressure psi	Overall Length mm	Air Hose inch (mm)	Packing
71-862	1/2" (Socket & Bits)	1/2" (13)	70/95	320	3.5	1/4"	90	260	3/8" (10)	1/20



Air Screwdriver



71-870

Twin Dog Clutch



71-871

Twin Dog Clutch

SPECIFICATION

Item No.	Clutch Mechanism	Chuck Size mm	Max Torque ft-lb/N-m	Free Speed RPM	Air Consumption CFM	Air Inlet	Air Pressure psi	Overall Length mm	Air Hose inch (mm)	Packing
71-870	Twin Dog	4~6mm	73/100	13,000	2.4	1/4"	90	185	3/8" (10)	1/20
71-871	Twin Dog	6~10mm	103/140	11,000	3.4	1/4"	90	205	3/8" (10)	1/12

Air Hydraulic Riveter



71-930



71-931

SPECIFICATION

Item No.	Blind Rivet Setting Capacity inch	Traction Power (Lbs)	Air Inlet	Length mm	Air Hose inch (mm)	Packing
71-930	Stainless 3/32", 1/8", 5/32", 3/16"	2,680	1/4"	275	3/8" (10)	1/10
	Aluminum 3/32", 1/8", 5/32", 3/16"					
71-931	Aluminum 3/32", 1/8", 5/32", 3/16"	4,166	1/4"	285	3/8" (10)	1/10
	Steel 5/32", 3/16", 7/32", 1/4"					

Pneumatic Tools

Air Nibbler



**** 30 % Quicker Cutting Speed
Derived from Our Diamond Tip
Cutting Edge.**



**71-901
Pull Type**

SPECIFICATION

Item No.	Type	Cutting Capability mm		Noise Level db(A)	Free Speed RPM	Air Consumption CFM	Air Inlet	Air Pressure psi	Overall Length mm	Air Hose inch (mm)	Packing
		Steel	Stainless Steel								
71-901	Pull	1.0	0.8	90	3,500	2	1/4"	90	195	3/8" (10)	1/20

Angle Grinder



**71-925
71-926**

Angle Polisher



**71-927
71-928**

SPECIFICATION

Item No.	Grinding Wheel inch	Free Speed RPM	Air Consumption CFM	Air Inlet	Air Pressure psi	Overall Length mm	Air Hose inch (mm)	Packing
71-926	5"	11,000	6	1/4"	90	242	3/8" (10)	1/10

SPECIFICATION

Item No.	Pad Size inch	Spindle Thread Size THD	Free Speed RPM	Air Consumption CFM	Air Inlet	Air Pressure psi	Overall Length mm	Air Hose inch (mm)	Packing
71-928	7"	5/8"-11	2,500	12	1/4"	90	406	3/8" (10)	1/6

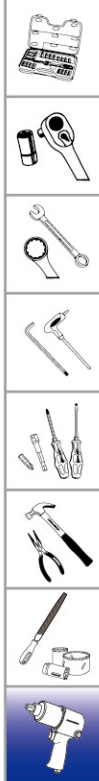

Random Orbital Sanders

- Low vibration for swirl-free finishes.
- Durable, lightweight composite housing design.
- Include low profile balance sanding pad.



71-934

3"

■ Non-Vacuum
2.5mm Random



71-935

5"

■ Non-Vacuum
5mm Random Orbital Sanders



71-936

6"

■ Non-Vacuum
5mm Random Orbital Sanders



71-937

5"

■ Self-Generated Vacuum
5mm Random Orbital Sanders

Hose & Bag



71-938

6"

■ Self-Generated Vacuum
5mm Random Orbital Sanders

Hose & Bag

SPECIFICATION

Item No.	Dust Disposal	Pad Dia. inch (mm)	Dia. Orbit mm	Noise Level db(A)	Vibration m/s ²	Free Speed RPM	Air Consumption CFM	Air Inlet	Air Hose inch (mm)	Packing
71-934	NON-VACUUM	3" (75)	2.5	80	0.8	11,000	1.6	1/4"	3/8" (10)	1/10
71-935	NON-VACUUM	5" (125)	5	80	0.8	11,000	1.6	1/4"	3/8" (10)	1/10
71-936	NON-VACUUM	6" (150)	5	80	0.8	11,000	1.6	1/4"	3/8" (10)	1/10
71-937	SELF-GENERATED VACUUM	5" (125)	5	80	0.8	11,000	1.6	1/4"	3/8" (10)	1/10
71-938	SELF-GENERATED VACUUM	6" (150)	5	80	0.8	11,000	1.6	1/4"	3/8" (10)	1/10

Pneumatic Tools

Air Body Saw



71-875
Rear Exhaust



71-876
Rear Exhaust

SPECIFICATION

Item No.	Stroke Length mm	Cutting Capacity (Steele)mm	Air Exhaust	Sound Level db(A)	Stroke Per Minute RPM	Air Consumption CFM	Air Inlet	Air Pressure psi	Overall Length mm	Air Hose inch (mm)	Packing
71-875	10	3	Rear	86	9,000	4	1/4"	90	235	3/8" (10)	1/20
71-876	10	3	Rear	82	5,000	4	1/4"	90	250	3/8" (10)	1/10

Cut-off Tool



71-880
Rear Exhaust

SPECIFICATION

Item No.	Cutting Blade inch	Motor HP	Air Exhaust	Sound Level db(A)	Free Speed RPM	Air Consumption CFM	Air Inlet	Air Pressure psi	Overall Length mm	Air Hose inch (mm)	Packing
71-880	3"	0.5	Rear	88	17,000	4	1/4"	90	210	3/8" (10)	1/10

Air Belt Sander



71-885
Rear Exhaust



71-886
Rear Exhaust



71-887
Rear Exhaust

SPECIFICATION

Item No.	Size of Belt mm	Motor HP	Air Exhaust	Sound Level db(A)	Free Speed RPM	Air Consumption CFM	Air Inlet	Air Pressure psi	Overall Length mm	Air Hose inch (mm)	Packing
71-885	10x330	0.6	Rear	88	16,000	4	1/4"	90	320	3/8" (10)	1/10
71-886	10x457	0.6	Rear	88	16,000	4	1/4"	90	320	3/8" (10)	1/10
71-887	20x520	0.6	Rear	88	16,000	4	1/4"	90	320	3/8" (10)	1/10



Die Grinder



71-890, 71-891

Rear Exhaust



71-892, 71-893

Rear Exhaust

Mini Die Grinder



71-894, 71-895

Rear Exhaust

Angle Die Grinder



71-896, 71-897

Rear Exhaust

Mini Angle Die Grinder



71-898, 71-899

Rear Exhaust

Die Grinder



71-900

Handle Exhaust

SPECIFICATION

Item No.	Collet Size	Motor HP	Air Exhaust	Sound Level db(A)	Free Speed RPM	Air Consumption CFM	Air Inlet	Air Pressure psi	Overall Length mm	Air Hose inch (mm)	Packing
71-890	6 mm	0.45	Rear	84	2,500	4	1/4"	90	210	3/8" (10)	1/10
71-891	6 mm	0.45	Rear	84	3,500	4	1/4"	90	210	3/8" (10)	1/10
71-892	1/4"	0.45	Rear	89	22,000	4	1/4"	90	170	3/8" (10)	1/20
71-893	6 mm	0.45	Rear	89	22,000	4	1/4"	90	170	3/8" (10)	1/20
71-894	1/4"	0.3	Rear	89	25,000	2.7	1/4"	90	150	3/8" (10)	1/20
71-895	6 mm	0.3	Rear	89	25,000	2.7	1/4"	90	150	3/8" (10)	1/20
71-896	1/4"	0.45	Rear	89	18,000	4	1/4"	90	170	3/8" (10)	1/20
71-897	6 mm	0.45	Rear	89	18,000	4	1/4"	90	170	3/8" (10)	1/20
71-898	1/4"	0.3	Rear	89	22,000	2.7	1/4"	90	158	3/8" (10)	1/20
71-899	6 mm	0.3	Rear	89	22,000	2.7	1/4"	90	158	3/8" (10)	1/20
71-900	1/4"	0.45	Handle	84	18,000	3.5	1/4"	90	155	3/8" (10)	1/10

Pneumatic Tools

Air Tire Buffer



71-905, 71-906
Rear Exhaust

Air Composite Polisher



71-910
Handle Exhaust

Air Composite Random Orbital Sander



71-911
Handle Exhaust

Air Surface Preparation Tool



71-912
Handle Exhaust

SPECIFICATION

Item No.	Motor HP	Air Exhaust	Sound Level db(A)	Free Speed RPM	Air Consumption CFM	Air Inlet	Air Pressure psi	Overall Length mm	Air Hose inch (mm)	Packing
71-905	0.45	Rear	89	2,500	4	1/4"	90	210	3/8" (10)	1/20
71-906	0.45	Rear	89	4,000	4	1/4"	90	210	3/8" (10)	1/20

SPECIFICATION

Item No.	Pad Size	Motor HP	Air Exhaust	Sound Level db(A)	Free Speed RPM	Spindle Size T	Air Consumption CFM	Air Inlet	Air Pressure psi	Overall Length mm	Air Hose inch (mm)	Packing
71-910	3"	0.45	Handle	84	2,200	5/16"-24	3.5	1/4"	90	135	3/8" (10)	1/10
71-911	3"	0.45	Handle	84	1,800	5/16"-24	3.5	1/4"	90	125	3/8" (10)	1/10
71-912	3"	0.45	Handle	84	1,800	1/4"-20	3.5	1/4"	90	145	3/8" (10)	1/10

Air Metal Shear

**** 30 % Quicker Cutting Speed**
Derived from Our Diamond Tip Cutting Edge.



71-882
Handle Exhaust

SPECIFICATION

Item No.	Cutting Capability mm	Motor HP	Air Exhaust	Sound Level db(A)	Free Speed RPM	Air Consumption CFM	Air Inlet	Air Pressure psi	Overall Length mm	Air Hose inch (mm)	Packing
71-882	Steel	1.2	0.45	88	2,500	4	1/4"	90	215	3/8" (10)	1/10
	Stainless Steel	0.8									

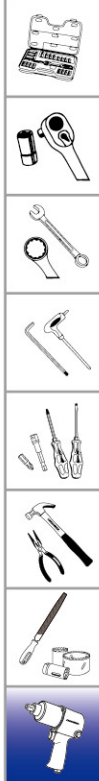

Adjustable Clutch Screwdriver



71-916

Handle Exhaust

Adjustable Clutch Screwdriver



71-917

Handle Exhaust

SPECIFICATION

Item No.	Capacity (Bore Size) inch	Motor HP	Air Exhaust	Sound Level db(A)	Free Speed RPM	Hex Shank Size inch	Air Consumption CFM	Max. Torque (In-Lb)	Air Inlet	Air Pressure psi	Overall Length mm	Air Hose inch (mm)	Packing
71-916	1/4"	0.45	Handle	88	2,000	1/4"	4	45-125	1/4"	90	195	3/8" (10)	1/10
71-917	1/4"	0.45	Handle	88	800	1/4"	4	45-160	1/4"	90	210	3/8" (10)	1/10

3/8" Air Reversible Drill



71-920

Handle Exhaust

1/2" Air Reversible Drill



71-921

Handle Exhaust



71-922

Handle Exhaust

SPECIFICATION

Item No.	Drilling Cap inch	Motor HP	Air Exhaust	Sound Level db(A)	Free Speed RPM	Air Consumption CFM	Air Inlet	Air Pressure psi	Overall Length mm	Air Hose inch (mm)	Packing
71-920	3/8"	0.45	Handle	88	2,000	4	1/4"	90	185	3/8" (10)	1/10
71-921	1/2"	0.45	Handle	88	550	4	1/4"	90	230	3/8" (10)	1/10
71-922	1/2"	0.45	Handle	88	800	4	1/4"	90	210	3/8" (10)	1/10

Pneumatic Tools



1/2" Drive Metric Air Impact Wrench Set - 15 Pcs.

Item No.		 kgs
74-010	1/2	5.5/12.0

- 1 Pc. Air Impact Wrench.
- 11 Pcs. Impact Sockets (Metric):
8, 10, 11, 12, 13, 14, 17, 19, 21, 22, 24 mm.
- 1 Pc. 2-1/2" (63mm) Impact Universal Joint .
- 1 Pc. 3" Impact Extension.
- 1 Pc. Air Inlet (1/4"PT or 1/4"NPT).
- 1 Pc. Blow Mold Box.

▲ Blow Mold Box



1/2" Drive Metric Air Impact Wrench Set - 15 Pcs.

Item No.		 kgs
74-011	1/4	4.1/17.4

- 1 Pc. Stubby Air Impact Wrench.
- 11 Pcs. Impact Sockets (Metric):
9, 10, 11, 12, 13, 14, 17, 19, 21, 22, 24 mm.
- 1 Pc. 2-1/2" (63mm) Impact Universal Joint.
- 1 Pc. 3" Impact Extension.
- 1 Pc. Air Inlet (1/4"PT or 1/4"NPT).

▲ Blow Mold Box



1/2" Drive Metric Air Impact Wrench Set - 26 Pcs.

Item No.		 kgs
74-012	1/2	5.4/11.2

- 1 Pc. Stubby Air Impact Wrench.
- 11 Pcs. Impact Sockets (Metric):
8, 10, 11, 12, 13, 14, 17, 19, 21, 22, 24 mm.
- 6 Pcs. Hex Head Impact Sockets 2-3/8" (60mm L):
5, 6, 8, 10, 12, 14 mm.
- 5 Pcs. TORX® Head Impact Sockets 2-3/8" (60mm L):
T30, T40, T45, T50, T55.
- 1 Pc. 2-1/2" (63mm) Impact Universal Joint.
- 1 Pc. 3" Impact Extension.
- 1 Pc. Air Inlet (1/4"PT or 1/4"NPT).

▲ Blow Mold Box



Pneumatic Tools

1/2" Drive Metric Air Impact Wrench Set - 44 Pcs.

Item No.		 kgs
74-013	1/2	5.5/11.8



- 1 Pc. Stubby Air Impact Wrench.
- 11 Pcs. Impact Sockets (Metric):
8, 10, 11, 12, 13, 14, 17, 19, 21, 22, 24 mm.
- 11 Pcs. Insert Bits (10mm x 75mm L):
 - Hex: 5, 6, 8, 10, 12 mm.
 - ⊕ TORX[®] Tamper Proof:
T30, T40, T45, T50, T55, T60.
- 17 Pcs. Insert Bits (10mm x 30mm L):
 - Hex: 5, 6, 8, 10, 12 mm.
 - ⊕ TORX[®] Tamper Proof:
T30, T40, T45, T50, T55, T60.
 - ⊖ Slotted: 10, 12, 14 mm.
 - ⊕ Phillips: PH2, PH3, PH4.
- 5 Pcs. Torx Hex Head Impact Sockets: T30, T40, T45, T50, T55
- 1 Pc. 10mm Hex Air Impact Quick Release Coupler.
- 1 Pc. 2-1/2" (63mm) Impact Universal Joint.
- 1 Pc. 3" Impact Extension.
- 1 Pc. Air Inlet (1/4"PT or 1/4"NPT).

▲ Blow Mold Box



DIAMOND TIP



P190 Screwdrivers

P202 Fastener Drive Tools

P205 Hex Key Wrenches

P208 Aviation Snips





10X LONGER LIFE



Phillips



Slotted

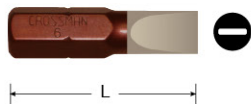

Hex



Insert Bits

DIAMOND TIP[®]

**** Microscope shows well-dispersed microcrystalline diamond in array all over the tip surface.**

Diamond Tip is always there

**** Powerful gripping force derived from our crystalline diamond grit that are constantly extruding & exposed.**

■ **Phillips Insert Bits - 1/4" Hex x 25mm L**

Item No.	Pt. Size	Shank Dia.	Overall Length		kgs
42-200	PH0	6.35mm(1/4")	25mm L	100/1000	0.7/8.0
42-201	PH1	6.35mm(1/4")	25mm L	100/1000	0.7/8.0
42-202	PH2	6.35mm(1/4")	25mm L	100/1000	0.7/8.0
42-203	PH3	6.35mm(1/4")	25mm L	100/1000	0.7/8.0
42-204	PH4	6.35mm(1/4")	25mm L	100/1000	0.7/8.0

■ **Slotted Insert Bits (Metric) - 1/4" Hex x 25mm L**

Item No.	Pt. Size	Shank Dia.	Overall Length		kgs
42-213	3mm	6.35mm(1/4")	25mm L	100/1000	0.7/8.0
42-214	4mm	6.35mm(1/4")	25mm L	100/1000	0.7/8.0
42-215	4.5mm	6.35mm(1/4")	25mm L	100/1000	0.7/8.0
42-216	5mm	6.35mm(1/4")	25mm L	100/1000	0.7/8.0
42-217	5.5mm	6.35mm(1/4")	25mm L	100/1000	0.7/8.0
42-218	6mm	6.35mm(1/4")	25mm L	100/1000	0.7/8.0
42-219	6.5mm	6.35mm(1/4")	25mm L	100/1000	0.7/8.0
42-220	7mm	6.35mm(1/4")	25mm L	100/1000	0.8/9.0
42-221	8mm	6.35mm(1/4")	25mm L	100/1000	0.9/10.0
42-222	10mm	6.35mm(1/4")	25mm L	100/1000	1.1/12.0

■ **Hex Insert Bits (SAE) - 1/4" Hex x 25mm L**

Item No.	Pt. Size	Shank Dia.	Overall Length		kgs
42-231	1/16"	6.35mm(1/4")	25mm L	100/1000	0.7/8.0
42-232	5/64"	6.35mm(1/4")	25mm L	100/1000	0.7/8.0
42-233	3/32"	6.35mm(1/4")	25mm L	100/1000	0.7/8.0
42-234	7/64"	6.35mm(1/4")	25mm L	100/1000	0.7/8.0
42-235	1/8"	6.35mm(1/4")	25mm L	100/1000	0.7/8.0
42-236	9/64"	6.35mm(1/4")	25mm L	100/1000	0.7/8.0
42-237	5/32"	6.35mm(1/4")	25mm L	100/1000	0.8/9.0
42-238	3/16"	6.35mm(1/4")	25mm L	100/1000	0.8/9.0
42-239	7/32"	6.35mm(1/4")	25mm L	100/1000	0.8/9.0
42-240	1/4"	6.35mm(1/4")	25mm L	100/1000	0.8/9.0
42-242	5/16"	6.35mm(1/4")	25mm L	100/1000	0.8/9.0
42-243	3/8"	6.35mm(1/4")	25mm L	100/1000	1.4/15.0



Insert Bits

DIAMOND TIP®

■ Hex Insert Bits (Metric) - 1/4" Hex x 25mm L

Item No.	Pt. Size	Shank Dia.	Overall Length			kgs
42-245	1.5mm	6.35mm(1/4")	25mm L	100/1000		0.7/8.0
42-246	2mm	6.35mm(1/4")	25mm L	100/1000		0.7/8.0
42-247	2.5mm	6.35mm(1/4")	25mm L	100/1000		0.7/8.0
42-248	3mm	6.35mm(1/4")	25mm L	100/1000		0.7/8.0
42-249	4mm	6.35mm(1/4")	25mm L	100/1000		0.7/8.0
42-250	5mm	6.35mm(1/4")	25mm L	100/1000		0.8/9.0
42-251	5.5mm	6.35mm(1/4")	25mm L	100/1000		0.8/9.0
42-252	6mm	6.35mm(1/4")	25mm L	100/1000		0.8/9.0
42-253	7mm	6.35mm(1/4")	25mm L	100/1000		0.8/9.0
42-254	8mm	6.35mm(1/4")	25mm L	100/1000		0.8/9.0
42-255	10mm	6.35mm(1/4")	25mm L	100/1000		1.4/15.0

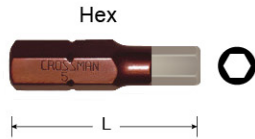

■ TORX® Insert Bits - 1/4" Hex x 25mm L

Item No.	Pt. Size	Shank Dia.	Overall Length			kgs
42-301	T-5	6.35mm(1/4")	25mm L	100/1000		0.4/5.0
42-302	T-6	6.35mm(1/4")	25mm L	100/1000		0.4/5.0
42-303	T-7	6.35mm(1/4")	25mm L	100/1000		0.4/5.0
42-304	T-8	6.35mm(1/4")	25mm L	100/1000		0.4/5.0
42-305	T-9	6.35mm(1/4")	25mm L	100/1000		0.4/5.0
42-306	T-10	6.35mm(1/4")	25mm L	100/1000		0.4/5.0
42-307	T-15	6.35mm(1/4")	25mm L	100/1000		0.4/5.0
42-308	T-20	6.35mm(1/4")	25mm L	100/1000		0.5/6.0
42-309	T-25	6.35mm(1/4")	25mm L	100/1000		0.5/6.0
42-310	T-27	6.35mm(1/4")	25mm L	100/1000		0.5/6.0
42-311	T-30	6.35mm(1/4")	25mm L	100/1000		0.5/6.0
42-312	T-35	6.35mm(1/4")	25mm L	100/1000		0.6/7.0
42-313	T-40	6.35mm(1/4")	25mm L	100/1000		0.6/7.0
42-314	T-45	6.35mm(1/4")	25mm L	100/1000		0.7/8.0
42-315	T-50	6.35mm(1/4")	25mm L	100/1000		0.8/9.0



■ POZIDRIV® Insert Bits - 1/4" Hex x 25mm L

Item No.	Pt. Size	Shank Dia.	Overall Length			kgs
42-340	PZ0	6.35mm(1/4")	25mm L	100/1000		0.7/8.0
42-341	PZ1	6.35mm(1/4")	25mm L	100/1000		0.7/8.0
42-342	PZ2	6.35mm(1/4")	25mm L	100/1000		0.7/8.0
42-343	PZ3	6.35mm(1/4")	25mm L	100/1000		0.7/8.0
42-344	PZ4	6.35mm(1/4")	25mm L	100/1000		0.8/9.0

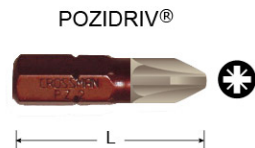

■ Square Recess Insert Bits - 1/4" Hex x 25mm L

Item No.	Pt. Size	Shank Dia.	Overall Length			kgs
42-370	S0	6.35mm(1/4")	25mm L	100/1000		0.7/8.0
42-371	S1	6.35mm(1/4")	25mm L	100/1000		0.7/8.0
42-372	S2	6.35mm(1/4")	25mm L	100/1000		0.7/8.0
42-373	S3	6.35mm(1/4")	25mm L	100/1000		0.7/8.0

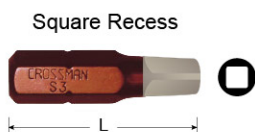



Power Bits



■ Phillips Power Bits - 1/4" Hex x 50mm L

Item No.	Pt. Size	Shank Dia.	Overall Length			kgs
42-400	PH0	6.35mm(1/4")	50mm L	100/1000		1.5/16.0
42-401	PH1	6.35mm(1/4")	50mm L	100/1000		1.5/16.0
42-402	PH2	6.35mm(1/4")	50mm L	100/1000		1.5/16.0
42-403	PH3	6.35mm(1/4")	50mm L	100/1000		1.6/17.0
42-404	PH4	6.35mm(1/4")	50mm L	100/1000		1.7/18.0

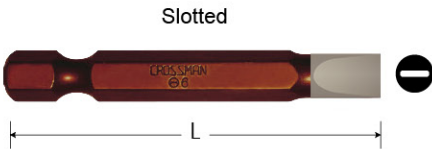

■ Slotted Power Bits (Metric) - 1/4" Hex x 50mm L

Item No.	Pt. Size	Shank Dia.	Overall Length			kgs
42-413	3mm	6.35mm(1/4")	50mm L	100/1000		1.4/15.0
42-414	4mm	6.35mm(1/4")	50mm L	100/1000		1.4/15.0
42-415	4.5mm	6.35mm(1/4")	50mm L	100/1000		1.4/15.0
42-416	5mm	6.35mm(1/4")	50mm L	100/1000		1.4/15.0
42-417	5.5mm	6.35mm(1/4")	50mm L	100/1000		1.4/15.0
42-418	6mm	6.35mm(1/4")	50mm L	100/1000		1.4/15.0
42-419	6.5mm	6.35mm(1/4")	50mm L	100/1000		1.5/16.0
42-420	7mm	6.35mm(1/4")	50mm L	100/1000		1.5/16.0
42-421	8mm	6.35mm(1/4")	50mm L	100/1000		1.6/17.0
42-422	10mm	6.35mm(1/4")	50mm L	100/1000		2.3/24.0



■ Hex Power Bits (SAE) - 1/4" Hex x 50mm L

Item No.	Pt. Size	Shank Dia.	Overall Length			kgs
42-431	1/16"	6.35mm(1/4")	50mm L	100/1000		1.4/15.0
42-432	5/64"	6.35mm(1/4")	50mm L	100/1000		1.4/15.0
42-433	3/32"	6.35mm(1/4")	50mm L	100/1000		1.4/15.0
42-434	7/64"	6.35mm(1/4")	50mm L	100/1000		1.4/15.0
42-435	1/8"	6.35mm(1/4")	50mm L	100/1000		1.4/15.0
42-436	9/64"	6.35mm(1/4")	50mm L	100/1000		1.4/15.0
42-437	5/32"	6.35mm(1/4")	50mm L	100/1000		1.4/15.0
42-438	3/16"	6.35mm(1/4")	50mm L	100/1000		1.4/15.0
42-439	7/32"	6.35mm(1/4")	50mm L	100/1000		1.4/15.0
42-440	1/4"	6.35mm(1/4")	50mm L	100/1000		1.5/16.0
42-441	9/32"	6.35mm(1/4")	50mm L	100/1000		1.5/16.0
42-442	5/16"	6.35mm(1/4")	50mm L	100/1000		1.6/17.0
42-443	3/8"	6.35mm(1/4")	50mm L	100/1000		2.4/25.0



Power Bits

DIAMOND TIP®

■ Hex Power Bits (Metric) - 1/4" Hex x 50mm L

Item No.	Pt. Size	Shank Dia.	Overall Length			kgs
42-445	1.5mm	6.35mm(1/4")	50mm L	100/1000		1.4/15.0
42-446	2mm	6.35mm(1/4")	50mm L	100/1000		1.4/15.0
42-447	2.5mm	6.35mm(1/4")	50mm L	100/1000		1.4/15.0
42-448	3mm	6.35mm(1/4")	50mm L	100/1000		1.4/15.0
42-449	4mm	6.35mm(1/4")	50mm L	100/1000		1.4/15.0
42-450	5mm	6.35mm(1/4")	50mm L	100/1000		1.4/15.0
42-451	5.5mm	6.35mm(1/4")	50mm L	100/1000		1.4/15.0
42-452	6mm	6.35mm(1/4")	50mm L	100/1000		1.4/15.0
42-453	7mm	6.35mm(1/4")	50mm L	100/1000		1.5/16.0
42-454	8mm	6.35mm(1/4")	50mm L	100/1000		1.6/17.0
42-455	10mm	6.35mm(1/4")	50mm L	100/1000		2.4/25.0



■ TORX® Power Bits - 1/4" Hex x 50mm L

Item No.	Pt. Size	Shank Dia.	Overall Length			kgs
42-506	T-10	6.35mm(1/4")	50mm L	100/1000		1.4/15.0
42-507	T-15	6.35mm(1/4")	50mm L	100/1000		1.4/15.0
42-508	T-20	6.35mm(1/4")	50mm L	100/1000		1.4/15.0
42-509	T-25	6.35mm(1/4")	50mm L	100/1000		1.4/15.0
42-510	T-27	6.35mm(1/4")	50mm L	100/1000		1.5/16.0
42-511	T-30	6.35mm(1/4")	50mm L	100/1000		1.5/16.0
42-513	T-40	6.35mm(1/4")	50mm L	100/1000		1.6/17.0
42-514	T-45	6.35mm(1/4")	50mm L	100/1000		2.1/22.0
42-515	T-50	6.35mm(1/4")	50mm L	100/1000		2.1/22.0



■ POZIDRIV® Power Bits - 1/4" Hex x 50mm L

Item No.	Pt. Size	Shank Dia.	Overall Length			kgs
42-540	PZ0	6.35mm(1/4")	50mm L	100/1000		1.4/15.0
42-541	PZ1	6.35mm(1/4")	50mm L	100/1000		1.4/15.0
42-542	PZ2	6.35mm(1/4")	50mm L	100/1000		1.5/16.0
42-543	PZ3	6.35mm(1/4")	50mm L	100/1000		1.5/16.0
42-544	PZ4	6.35mm(1/4")	50mm L	100/1000		1.7/18.0



■ Square Recess Power Bits - 1/4" Hex x 50mm L

Item No.	Pt. Size	Shank Dia.	Overall Length			kgs
42-570	S0	6.35mm(1/4")	50mm L	100/1000		1.4/15.0
42-571	S1	6.35mm(1/4")	50mm L	100/1000		1.4/15.0
42-572	S2	6.35mm(1/4")	50mm L	100/1000		1.5/16.0
42-573	S3	6.35mm(1/4")	50mm L	100/1000		1.6/17.0

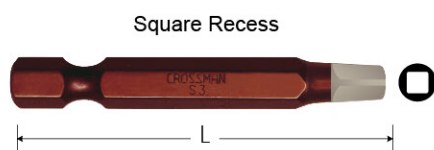



■ Phillips Power Bits - 1/4" Hex x 75mm L

Item No.	Pt. Size	Shank Dia.	Overall Length			kgs
42-780	PH0	6.35mm(1/4")	75mm L	100/1000		1.8/18.5
42-781	PH1	6.35mm(1/4")	75mm L	100/1000		1.8/18.5
42-782	PH2	6.35mm(1/4")	75mm L	100/1000		1.8/18.5
42-783	PH3	6.35mm(1/4")	75mm L	100/1000		1.8/18.5
42-784	PH4	6.35mm(1/4")	75mm L	100/1000		1.8/18.5



■ Slotted Power Bits (Metric) - 1/4" Hex x 75mm L

Item No.	Pt. Size	Shank Dia.	Overall Length			kgs
42-785	3mm	6.35mm(1/4")	75mm L	100/1000		1.8/18.5
42-786	4mm	6.35mm(1/4")	75mm L	100/1000		1.8/18.5
42-787	4.5mm	6.35mm(1/4")	75mm L	100/1000		1.8/18.5
42-788	5mm	6.35mm(1/4")	75mm L	100/1000		1.8/18.5
42-789	5.5mm	6.35mm(1/4")	75mm L	100/1000		1.8/18.5
42-790	6mm	6.35mm(1/4")	75mm L	100/1000		1.8/18.5
42-791	6.5mm	6.35mm(1/4")	75mm L	100/1000		1.8/18.5
42-792	7mm	6.35mm(1/4")	75mm L	100/1000		1.9/19.0
42-793	8mm	6.35mm(1/4")	75mm L	100/1000		1.9/19.0
42-794	10mm	6.35mm(1/4")	75mm L	100/1000		1.9/19.0



■ Hex Power Bits (SAE) - 1/4" Hex x 75mm L

Item No.	Pt. Size	Shank Dia.	Overall Length			kgs
42-801	1/16"	6.35mm(1/4")	75mm L	100/1000		1.8/18.5
42-802	5/64"	6.35mm(1/4")	75mm L	100/1000		1.8/18.5
42-803	3/32"	6.35mm(1/4")	75mm L	100/1000		1.8/18.5
42-804	7/64"	6.35mm(1/4")	75mm L	100/1000		1.8/18.5
42-805	1/8"	6.35mm(1/4")	75mm L	100/1000		1.8/18.5
42-806	9/64"	6.35mm(1/4")	75mm L	100/1000		1.8/18.5
42-807	5/32"	6.35mm(1/4")	75mm L	100/1000		1.9/19.0
42-808	3/16"	6.35mm(1/4")	75mm L	100/1000		1.9/19.0
42-809	7/32"	6.35mm(1/4")	75mm L	100/1000		1.9/19.0
42-810	1/4"	6.35mm(1/4")	75mm L	100/1000		1.9/19.0
42-811	9/32"	6.35mm(1/4")	75mm L	100/1000		1.9/19.0
42-812	5/16"	6.35mm(1/4")	75mm L	100/1000		1.9/19.0
42-813	3/8"	6.35mm(1/4")	75mm L	100/1000		1.9/19.0



Power Bits

DIAMOND TIP®

■ Hex Power Bits (Metric) - 1/4" Hex x 75mm L

Item No.	Pt. Size	Shank Dia.	Overall Length	 	 kgs
42-820	1.5mm	6.35mm(1/4")	75mm L	100/1000	1.8/18.5
42-821	2mm	6.35mm(1/4")	75mm L	100/1000	1.8/18.5
42-822	2.5mm	6.35mm(1/4")	75mm L	100/1000	1.8/18.5
42-823	3mm	6.35mm(1/4")	75mm L	100/1000	1.8/18.5
42-824	4mm	6.35mm(1/4")	75mm L	100/1000	1.8/18.5
42-825	5mm	6.35mm(1/4")	75mm L	100/1000	1.8/18.5
42-826	5.5mm	6.35mm(1/4")	75mm L	100/1000	1.8/18.5
42-827	6mm	6.35mm(1/4")	75mm L	100/1000	1.8/18.5
42-828	7mm	6.35mm(1/4")	75mm L	100/1000	1.9/19.0
42-829	8mm	6.35mm(1/4")	75mm L	100/1000	1.9/19.0
42-830	10mm	6.35mm(1/4")	75mm L	100/1000	1.9/19.0





■ TORX® Power Bits - 1/4" Hex x 75mm L

Item No.	Pt. Size	Shank Dia.	Overall Length	 	 kgs
42-871	T-10	6.35mm(1/4")	75mm L	100/1000	1.8/18.5
42-872	T-15	6.35mm(1/4")	75mm L	100/1000	1.8/18.5
42-873	T-20	6.35mm(1/4")	75mm L	100/1000	1.8/18.5
42-874	T-25	6.35mm(1/4")	75mm L	100/1000	1.8/18.5
42-875	T-27	6.35mm(1/4")	75mm L	100/1000	1.8/18.5
42-876	T-30	6.35mm(1/4")	75mm L	100/1000	1.8/18.5
42-877	T-40	6.35mm(1/4")	75mm L	100/1000	1.8/18.5
42-878	T-45	6.35mm(1/4")	75mm L	100/1000	1.8/18.5
42-879	T-50	6.35mm(1/4")	75mm L	100/1000	1.9/19.0





■ POZIDRIV® Power Bits - 1/4" Hex x 75mm L

Item No.	Pt. Size	Shank Dia.	Overall Length	 	 kgs
42-890	PZ0	6.35mm(1/4")	75mm L	100/1000	1.8/18.5
42-891	PZ1	6.35mm(1/4")	75mm L	100/1000	1.8/18.5
42-892	PZ2	6.35mm(1/4")	75mm L	100/1000	1.8/18.5
42-893	PZ3	6.35mm(1/4")	75mm L	100/1000	1.8/18.5
42-894	PZ4	6.35mm(1/4")	75mm L	100/1000	1.8/18.5



■ Square Recess Power Bits - 1/4" Hex x 75mm L

Item No.	Pt. Size	Shank Dia.	Overall Length	 	 kgs
42-896	S0	6.35mm(1/4")	75mm L	100/1000	1.8/18.5
42-897	S1	6.35mm(1/4")	75mm L	100/1000	1.8/18.5
42-898	S2	6.35mm(1/4")	75mm L	100/1000	1.8/18.5
42-899	S3	6.35mm(1/4")	75mm L	100/1000	1.8/18.5

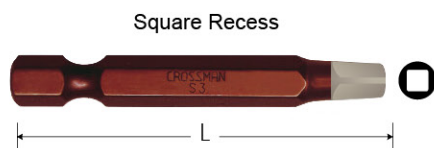

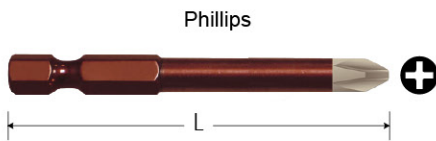

Phillips

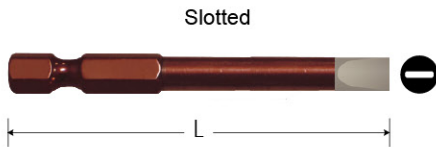

Slotted

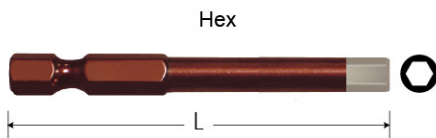

Hex

Power Bits



■ Round Shank Phillips Power Bits - 1/4" Hex x 75mm L

Item No.	Pt. Size	Shank Dia.	Overall Length			kg
43-101	PH0	6.35mm(1/4")	75mm L	100/1000		1.6/16.5
43-102	PH1	6.35mm(1/4")	75mm L	100/1000		1.6/16.5
43-103	PH2	6.35mm(1/4")	75mm L	100/1000		1.6/16.5
43-104	PH3	6.35mm(1/4")	75mm L	100/1000		1.6/16.5
43-105	PH4	6.35mm(1/4")	75mm L	100/1000		1.6/16.5

■ Round Shank Slotted Power Bits (Metric) - 1/4" Hex x 75mm L

Item No.	Pt. Size	Shank Dia.	Overall Length			kg
43-110	3mm	6.35mm(1/4")	75mm L	100/1000		1.6/16.5
43-111	4mm	6.35mm(1/4")	75mm L	100/1000		1.6/16.5
43-112	4.5mm	6.35mm(1/4")	75mm L	100/1000		1.6/16.5
43-113	5mm	6.35mm(1/4")	75mm L	100/1000		1.6/16.5
43-114	5.5mm	6.35mm(1/4")	75mm L	100/1000		1.6/16.5
43-115	6mm	6.35mm(1/4")	75mm L	100/1000		1.6/16.5
43-116	6.5mm	6.35mm(1/4")	75mm L	100/1000		1.7/17.5
43-117	7mm	6.35mm(1/4")	75mm L	100/1000		1.7/17.5
43-118	8mm	6.35mm(1/4")	75mm L	100/1000		1.7/17.5
43-119	10mm	6.35mm(1/4")	75mm L	100/1000		1.7/17.5

■ Round Shank Hex Power Bits (SAE) - 1/4" Hex x 75mm L

Item No.	Pt. Size	Shank Dia.	Overall Length			kg
43-120	1/16"	6.35mm(1/4")	75mm L	100/1000		1.6/16.5
43-121	5/64"	6.35mm(1/4")	75mm L	100/1000		1.6/16.5
43-122	3/32"	6.35mm(1/4")	75mm L	100/1000		1.6/16.5
43-123	7/64"	6.35mm(1/4")	75mm L	100/1000		1.6/16.5
43-124	1/8"	6.35mm(1/4")	75mm L	100/1000		1.6/16.5
43-125	9/64"	6.35mm(1/4")	75mm L	100/1000		1.6/16.5
43-126	5/32"	6.35mm(1/4")	75mm L	100/1000		1.6/16.5
43-127	3/16"	6.35mm(1/4")	75mm L	100/1000		1.7/17.5
43-128	7/32"	6.35mm(1/4")	75mm L	100/1000		1.7/17.5
43-129	1/4"	6.35mm(1/4")	75mm L	100/1000		1.7/17.5
43-130	9/32"	6.35mm(1/4")	75mm L	100/1000		1.7/17.5
43-131	5/16"	6.35mm(1/4")	75mm L	100/1000		1.7/17.5
43-132	3/8"	6.35mm(1/4")	75mm L	100/1000		1.7/17.5



Power Bits

DIAMOND TIP®

■ Round Shank Hex Power Bits (Metric) - 1/4" Hex x 75mm L

Item No.	Pt. Size	Shank Dia.	Overall Length	 	 kgs
43-140	1.5mm	6.35mm(1/4")	75mm L	100/1000	1.6/16.5
43-141	2mm	6.35mm(1/4")	75mm L	100/1000	1.6/16.5
43-142	2.5mm	6.35mm(1/4")	75mm L	100/1000	1.6/16.5
43-143	3mm	6.35mm(1/4")	75mm L	100/1000	1.6/16.5
43-144	4mm	6.35mm(1/4")	75mm L	100/1000	1.6/16.5
43-145	5mm	6.35mm(1/4")	75mm L	100/1000	1.6/16.5
43-146	5.5mm	6.35mm(1/4")	75mm L	100/1000	1.6/16.5
43-147	6mm	6.35mm(1/4")	75mm L	100/1000	1.6/16.5
43-148	7mm	6.35mm(1/4")	75mm L	100/1000	1.7/17.5
43-149	8mm	6.35mm(1/4")	75mm L	100/1000	1.7/17.5
43-150	10mm	6.35mm(1/4")	75mm L	100/1000	1.7/17.5

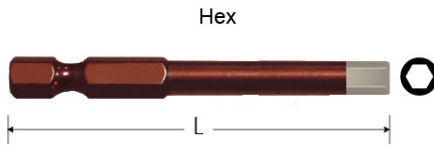

■ Round Shank TORX® Power Bits - 1/4" Hex x 75mm L

Item No.	Pt. Size	Shank Dia.	Overall Length	 	 kgs
43-151	T-10	6.35mm(1/4")	75mm L	100/1000	1.6/16.5
43-152	T-15	6.35mm(1/4")	75mm L	100/1000	1.6/16.5
43-153	T-20	6.35mm(1/4")	75mm L	100/1000	1.6/16.5
43-154	T-25	6.35mm(1/4")	75mm L	100/1000	1.6/16.5
43-155	T-27	6.35mm(1/4")	75mm L	100/1000	1.6/16.5
43-156	T-30	6.35mm(1/4")	75mm L	100/1000	1.6/16.5
43-157	T-40	6.35mm(1/4")	75mm L	100/1000	1.6/16.5
43-158	T-45	6.35mm(1/4")	75mm L	100/800	1.6/16.5
43-159	T-50	6.35mm(1/4")	75mm L	100/800	1.7/17.5

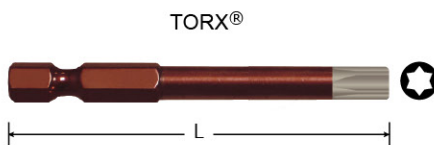

■ Round Shank POZIDRIV® Power Bits - 1/4" Hex x 75mm L

Item No.	Pt. Size	Shank Dia.	Overall Length	 	 kgs
43-170	PZ0	6.35mm(1/4")	75mm L	100/1000	1.6/16.5
43-171	PZ1	6.35mm(1/4")	75mm L	100/1000	1.6/16.5
43-172	PZ2	6.35mm(1/4")	75mm L	100/1000	1.6/16.5
43-173	PZ3	6.35mm(1/4")	75mm L	100/1000	1.6/16.5
43-174	PZ4	6.35mm(1/4")	75mm L	100/1000	1.6/16.5



■ Round Shank Square Recess Power Bits - 1/4" Hex x 75mm L

Item No.	Pt. Size	Shank Dia.	Overall Length	 	 kgs
43-180	S0	6.35mm(1/4")	75mm L	100/1000	1.6/16.5
43-181	S1	6.35mm(1/4")	75mm L	100/1000	1.6/16.5
43-182	S2	6.35mm(1/4")	75mm L	100/1000	1.6/16.5
43-183	S3	6.35mm(1/4")	75mm L	100/1000	1.6/16.5

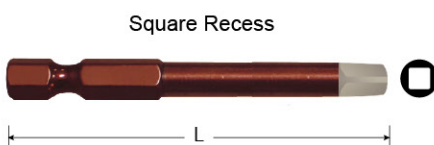

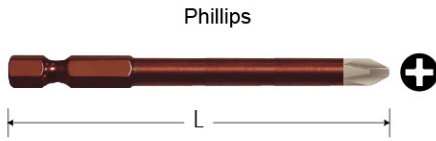

Phillips

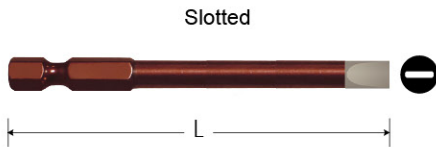

Slotted

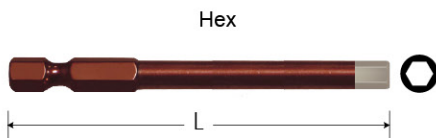

Hex

Power Bits



■ Round Shank Phillips Power Bits - 1/4" Hex x 100mm L

Item No.	Pt. Size	Shank Dia.	Overall Length			kgs
43-201	PH0	6.35mm(1/4")	100mm L	100/1000		2.2/22.0
43-202	PH1	6.35mm(1/4")	100mm L	100/1000		2.2/22.0
43-203	PH2	6.35mm(1/4")	100mm L	100/1000		2.2/22.0
43-204	PH3	6.35mm(1/4")	100mm L	100/1000		2.2/22.0
43-205	PH4	6.35mm(1/4")	100mm L	100/1000		2.2/22.0

■ Round Shank Slotted Power Bits (Metric) - 1/4" Hex x 100mm L

Item No.	Pt. Size	Shank Dia.	Overall Length			kgs
43-210	3mm	6.35mm(1/4")	100mm L	100/1000		2.2/22.0
43-211	4mm	6.35mm(1/4")	100mm L	100/1000		2.2/22.0
43-212	4.5mm	6.35mm(1/4")	100mm L	100/1000		2.2/22.0
43-213	5mm	6.35mm(1/4")	100mm L	100/1000		2.2/22.0
43-214	5.5mm	6.35mm(1/4")	100mm L	100/1000		2.2/22.0
43-215	6mm	6.35mm(1/4")	100mm L	100/1000		2.2/22.0
43-216	6.5mm	6.35mm(1/4")	100mm L	100/1000		2.3/23.0
43-217	7mm	6.35mm(1/4")	100mm L	100/1000		2.3/23.0
43-218	8mm	6.35mm(1/4")	100mm L	100/1000		2.3/23.0
43-219	10mm	6.35mm(1/4")	100mm L	100/1000		2.3/23.0

■ Round Shank Hex Power Bits (SAE) - 1/4" Hex x 100mm L

Item No.	Pt. Size	Shank Dia.	Overall Length			kgs
43-220	1/16"	6.35mm(1/4")	100mm L	100/1000		2.2/22.0
43-221	5/64"	6.35mm(1/4")	100mm L	100/1000		2.2/22.0
43-222	3/32"	6.35mm(1/4")	100mm L	100/1000		2.2/22.0
43-223	7/64"	6.35mm(1/4")	100mm L	100/1000		2.2/22.0
43-224	1/8"	6.35mm(1/4")	100mm L	100/1000		2.2/22.0
43-225	9/64"	6.35mm(1/4")	100mm L	100/1000		2.2/22.0
43-226	5/32"	6.35mm(1/4")	100mm L	100/1000		2.2/22.0
43-227	3/16"	6.35mm(1/4")	100mm L	100/1000		2.3/23.0
43-228	7/32"	6.35mm(1/4")	100mm L	100/1000		2.3/23.0
43-229	1/4"	6.35mm(1/4")	100mm L	100/1000		2.3/23.0
43-230	9/32"	6.35mm(1/4")	100mm L	100/1000		2.3/23.0
43-231	5/16"	6.35mm(1/4")	100mm L	100/1000		2.3/23.0
43-232	3/8"	6.35mm(1/4")	100mm L	100/1000		2.3/23.0



Power Bits

DIAMOND TIP®

■ Round Shank Hex Power Bits (Metric) - 1/4" Hex x 100mm L

Item No.	Pt. Size	Shank Dia.	Overall Length			kgs
43-240	1.5mm	6.35mm(1/4")	100mm L	100/1000		2.2/22.0
43-241	2mm	6.35mm(1/4")	100mm L	100/1000		2.2/22.0
43-242	2.5mm	6.35mm(1/4")	100mm L	100/1000		2.2/22.0
43-243	3mm	6.35mm(1/4")	100mm L	100/1000		2.2/22.0
43-244	4mm	6.35mm(1/4")	100mm L	100/1000		2.2/22.0
43-245	5mm	6.35mm(1/4")	100mm L	100/1000		2.2/22.0
43-246	5.5mm	6.35mm(1/4")	100mm L	100/1000		2.2/22.0
43-247	6mm	6.35mm(1/4")	100mm L	100/1000		2.2/22.0
43-248	7mm	6.35mm(1/4")	100mm L	100/1000		2.3/23.0
43-249	8mm	6.35mm(1/4")	100mm L	100/1000		2.3/23.0
43-250	10mm	6.35mm(1/4")	100mm L	100/1000		2.3/23.0

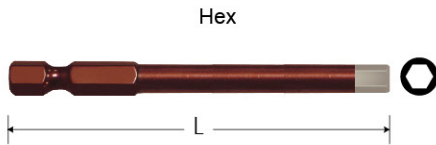

■ Round Shank TORX® Power Bits - 1/4" Hex x 100mm L

Item No.	Pt. Size	Shank Dia.	Overall Length			kgs
43-251	T-10	6.35mm(1/4")	100mm L	100/1000		2.2/22.0
43-252	T-15	6.35mm(1/4")	100mm L	100/1000		2.2/22.0
43-253	T-20	6.35mm(1/4")	100mm L	100/1000		2.2/22.0
43-254	T-25	6.35mm(1/4")	100mm L	100/1000		2.2/22.0
43-255	T-27	6.35mm(1/4")	100mm L	100/1000		2.2/22.0
43-256	T-30	6.35mm(1/4")	100mm L	100/1000		2.2/22.0
43-257	T-40	6.35mm(1/4")	100mm L	100/1000		2.2/22.0
43-258	T-45	6.35mm(1/4")	100mm L	100/800		2.2/22.0
43-259	T-50	6.35mm(1/4")	100mm L	100/800		2.3/23.0



■ Round Shank POZIDRIV® Power Bits - 1/4" Hex x 100mm L

Item No.	Pt. Size	Shank Dia.	Overall Length			kgs
43-270	PZ0	6.35mm(1/4")	100mm L	100/1000		2.2/22.0
43-271	PZ1	6.35mm(1/4")	100mm L	100/1000		2.2/22.0
43-272	PZ2	6.35mm(1/4")	100mm L	100/1000		2.2/22.0
43-273	PZ3	6.35mm(1/4")	100mm L	100/1000		2.2/22.0
43-274	PZ4	6.35mm(1/4")	100mm L	100/1000		2.2/22.0



■ Round Shank Square Recess Power Bits - 1/4" Hex x 100mm L

Item No.	Pt. Size	Shank Dia.	Overall Length			kgs
43-280	S0	6.35mm(1/4")	100mm L	100/1000		2.2/22.0
43-281	S1	6.35mm(1/4")	100mm L	100/1000		2.2/22.0
43-282	S2	6.35mm(1/4")	100mm L	100/1000		2.2/22.0
43-283	S3	6.35mm(1/4")	100mm L	100/1000		2.2/22.0

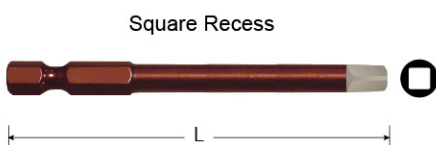

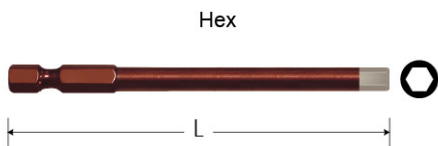
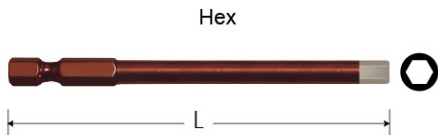
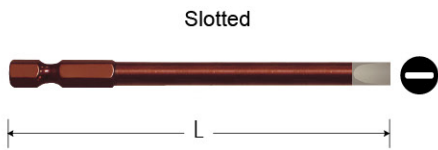
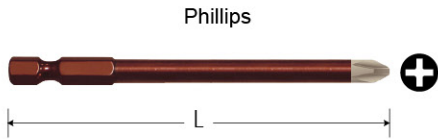

Power Bits



Round Shank Phillips Power Bits - 1/4" Hex x 150mm L

Item No.	Pt. Size	Shank Dia.	Overall Length			kgs
43-301	PH0	6.35mm(1/4")	150mm L	100/600		3.3/19.8
43-302	PH1	6.35mm(1/4")	150mm L	100/600		3.3/19.8
43-303	PH2	6.35mm(1/4")	150mm L	100/600		3.3/19.8
43-304	PH3	6.35mm(1/4")	150mm L	100/600		3.3/19.8
43-305	PH4	6.35mm(1/4")	150mm L	100/600		3.3/19.8

Round Shank Slotted Power Bits (Metric) - 1/4" Hex x 150mm L

Item No.	Pt. Size	Shank Dia.	Overall Length			kgs
43-310	3mm	6.35mm(1/4")	150mm L	100/600		3.3/19.8
43-311	4mm	6.35mm(1/4")	150mm L	100/600		3.3/19.8
43-312	4.5mm	6.35mm(1/4")	150mm L	100/600		3.3/19.8
43-313	5mm	6.35mm(1/4")	150mm L	100/600		3.3/19.8
43-314	5.5mm	6.35mm(1/4")	150mm L	100/600		3.3/19.8
43-315	6mm	6.35mm(1/4")	150mm L	100/600		3.3/19.8
43-316	6.5mm	6.35mm(1/4")	150mm L	100/600		3.4/20.4
43-317	7mm	6.35mm(1/4")	150mm L	100/600		3.4/20.4
43-318	8mm	6.35mm(1/4")	150mm L	100/600		3.4/20.4
43-319	10mm	6.35mm(1/4")	150mm L	100/600		3.4/20.4

Round Shank Hex Power Bits (SAE) - 1/4" Hex x 150mm L

Item No.	Pt. Size	Shank Dia.	Overall Length			kgs
43-320	1/16"	6.35mm(1/4")	150mm L	100/600		3.3/19.8
43-321	5/64"	6.35mm(1/4")	150mm L	100/600		3.3/19.8
43-322	3/32"	6.35mm(1/4")	150mm L	100/600		3.3/19.8
43-323	7/64"	6.35mm(1/4")	150mm L	100/600		3.3/19.8
43-324	1/8"	6.35mm(1/4")	150mm L	100/600		3.3/19.8
43-325	9/64"	6.35mm(1/4")	150mm L	100/600		3.3/19.8
43-326	5/32"	6.35mm(1/4")	150mm L	100/600		3.3/19.8
43-327	3/16"	6.35mm(1/4")	150mm L	100/600		3.3/19.8
43-328	7/32"	6.35mm(1/4")	150mm L	100/600		3.4/20.4
43-329	1/4"	6.35mm(1/4")	150mm L	100/600		3.4/20.4
43-330	9/32"	6.35mm(1/4")	150mm L	100/600		3.4/20.4
43-331	5/16"	6.35mm(1/4")	150mm L	100/600		3.4/20.4
43-332	3/8"	6.35mm(1/4")	150mm L	100/600		3.4/20.4

Round Shank Hex Power Bits (Metric) - 1/4" Hex x 150mm L

Item No.	Pt. Size	Shank Dia.	Overall Length			kgs
43-340	1.5mm	6.35mm(1/4")	150mm L	100/600		3.3/19.8
43-341	2mm	6.35mm(1/4")	150mm L	100/600		3.3/19.8
43-342	2.5mm	6.35mm(1/4")	150mm L	100/600		3.3/19.8
43-343	3mm	6.35mm(1/4")	150mm L	100/600		3.3/19.8
43-344	4mm	6.35mm(1/4")	150mm L	100/600		3.3/19.8
43-345	5mm	6.35mm(1/4")	150mm L	100/600		3.3/19.8
43-346	5.5mm	6.35mm(1/4")	150mm L	100/600		3.3/19.8
43-347	6mm	6.35mm(1/4")	150mm L	100/600		3.3/19.8
43-348	7mm	6.35mm(1/4")	150mm L	100/600		3.4/20.4
43-349	8mm	6.35mm(1/4")	150mm L	100/600		3.4/20.4
43-350	10mm	6.35mm(1/4")	150mm L	100/600		3.4/20.4



Power Bits



■ Round Shank TORX® Power Bits - 1/4" Hex x 150mm L

Item No.	Pt. Size	Shank Dia.	Overall Length			kgs
43-351	T-10	6.35mm(1/4")	150mm L	100/600		3.3/19.8
43-352	T-15	6.35mm(1/4")	150mm L	100/600		3.3/19.8
43-353	T-20	6.35mm(1/4")	150mm L	100/600		3.3/19.8
43-354	T-25	6.35mm(1/4")	150mm L	100/600		3.3/19.8
43-355	T-27	6.35mm(1/4")	150mm L	100/600		3.3/19.8
43-356	T-30	6.35mm(1/4")	150mm L	100/600		3.3/19.8
43-357	T-40	6.35mm(1/4")	150mm L	100/600		3.3/19.8
43-358	T-45	6.35mm(1/4")	150mm L	100/600		3.3/19.8
43-359	T-50	6.35mm(1/4")	150mm L	100/600		3.4/20.4



■ Round Shank POZIDRIV® Power Bits - 1/4" Hex x 150mm L

Item No.	Pt. Size	Shank Dia.	Overall Length			kgs
43-370	PZ0	6.35mm(1/4")	150mm L	100/600		3.3/19.8
43-371	PZ1	6.35mm(1/4")	150mm L	100/600		3.3/19.8
43-372	PZ2	6.35mm(1/4")	150mm L	100/600		3.3/19.8
43-373	PZ3	6.35mm(1/4")	150mm L	100/600		3.3/19.8
43-374	PZ4	6.35mm(1/4")	150mm L	100/600		3.3/19.8



■ Round Shank Square Recess Power Bits - 1/4" Hex x 150mm L

Item No.	Pt. Size	Shank Dia.	Overall Length			kgs
43-380	S0	6.35mm(1/4")	150mm L	100/600		3.3/19.8
43-381	S1	6.35mm(1/4")	150mm L	100/600		3.3/19.8
43-382	S2	6.35mm(1/4")	150mm L	100/600		3.3/19.8
43-383	S3	6.35mm(1/4")	150mm L	100/600		3.3/19.8

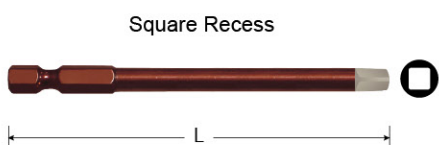

■ Phillips Double End Bits- 1/4" Hex

Item No.	Pt. Size	Shank Dia.	Overall Length			kgs
42-910	PH2	6.35mm(1/4")	65mm L	100/600		1.6/16.0
42-911	PH3	6.35mm(1/4")	65mm L	100/600		1.6/16.0
42-916	PH2	6.35mm(1/4")	90mm L	100/600		2.2/22.0
42-917	PH3	6.35mm(1/4")	90mm L	100/600		2.2/22.0
42-920	PH2	6.35mm(1/4")	120mm L	100/600		2.9/17.4
42-921	PH3	6.35mm(1/4")	120mm L	100/600		2.9/17.4
42-926	PH2	6.35mm(1/4")	150mm L	100/600		3.7/22.3
42-927	PH3	6.35mm(1/4")	150mm L	100/600		3.7/22.3





10X LONGER LIFE



Screwdrivers **DIAMOND TIP®**

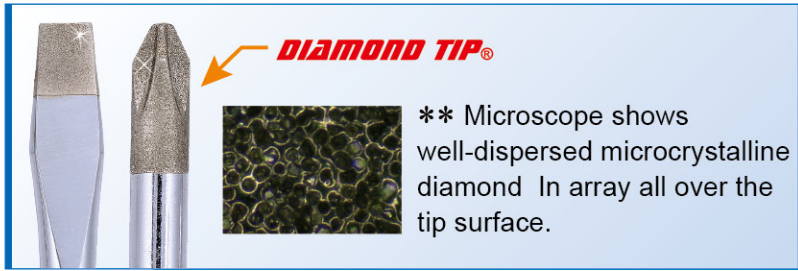

Diamond Tip is always there

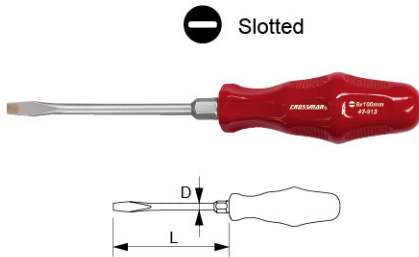

■ Diamond Tip® Hex Acetate Handle Screwdrivers - Slotted w/Hex Bolster

Item No.	Pt. Size	Size (DxL)		📦	⚖️ kgs
		inch	mm		
47-911	5 mm	3/16" x 3"	5 x 75	12/300	0.8/20.0
47-912	5 mm	3/16" x 4"	5 x 100	12/300	0.9/22.1
47-913	6 mm	1/4" x 4"	6 x 100	12/240	1.2/23.0
47-914	6 mm	1/4" x 6"	6 x 150	12/120	1.3/13.0
47-915	8 mm	5/16" x 6"	8 x 150	12/120	2.1/21.8
47-916	8 mm	5/16" x 8"	8 x 200	12/120	2.4/24.4

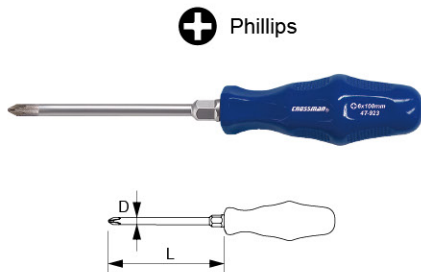

■ Diamond Tip® Hex Acetate Handle Screwdrivers - Phillips w/Hex Bolster

Item No.	Pt. Size	Size (DxL)		📦	⚖️ kgs
		inch	mm		
47-921	PH1	3/16" x 3"	5 x 75	12/300	0.8/20.0
47-922	PH1	3/16" x 4"	5 x 100	12/300	0.9/22.1
47-923	PH2	1/4" x 4"	6 x 100	12/240	1.2/23.0
47-924	PH2	1/4" x 6"	6 x 150	12/240	1.3/13.0
47-925	PH3	5/16" x 6"	8 x 150	12/120	2.1/21.8
47-926	PH3	5/16" x 8"	8 x 200	12/120	2.4/24.4

- ** Crossman platinum shaft; hardened but high ductility.
- ** Handle is made of eco-friendly acetate w/fiber.
- ** Ideal for auto, agricultural machinery & equipments etc.



Screwdrivers **DIAMOND TIP[®]**

■ Diamond Tip[®] Line Color Acetate Handle Screwdrivers - Slotted w/Hex Bolster

Item No.	Pt. Size	Size (DxL)		Pkg	kgs
		inch	mm		
47-630	5 mm	3/16" x 3"	5 x 75	12/300	0.8/20.0
47-631	5 mm	3/16" x 4"	5 x 100	12/300	0.9/22.1
47-632	6 mm	1/4" x 4"	6 x 100	12/240	1.2/23.0
47-633	6 mm	1/4" x 6"	6 x 150	12/240	1.2/24.0
47-634	8 mm	5/16" x 6"	8 x 150	6/120	0.7/13.5
47-635	8 mm	5/16" x 8"	8 x 200	6/120	0.7/14.5
47-636	10 mm	3/8" x 8"	10 x 200	6/60	2.4/24.0
47-637	10 mm	3/8" x 10"	10 x 250	6/48	2.6/20.8

⊖ Slotted

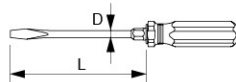

■ Diamond Tip[®] Line Color Acetate Handle Screwdrivers - Phillips w/Hex Bolster

Item No.	Pt. Size	Size (DxL)		Pkg	kgs
		inch	mm		
47-640	PH1	3/16" x 3"	5 x 75	12/300	0.8/20.0
47-641	PH1	3/16" x 4"	5 x 100	12/300	0.9/22.1
47-642	PH2	1/4" x 4"	6 x 100	12/240	1.2/23.0
47-643	PH2	1/4" x 6"	6 x 150	12/240	1.2/24.0
47-644	PH3	5/16" x 6"	8 x 150	6/120	0.7/13.5
47-645	PH3	5/16" x 8"	8 x 200	6/120	0.7/14.5
47-646	PH4	3/8" x 8"	10 x 200	6/60	2.4/24.0
47-647	PH4	3/8" x 10"	10 x 250	6/48	2.6/20.8

⊕ Phillips

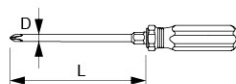

- ** Crossman platinum shaft; hardened but high ductility.
- ** Handle is made of eco-friendly acetate w/fiber.
- ** Ideal for auto repairing & mechanical & machinery etc.

■ Diamond Tip[®] Advanced Cushion Grip/Acetate Handle Screwdriver - Slotted w/Hex Bolster

Item No.	Pt. Size	Size (DxL)		Pkg	kgs
		inch	mm		
47-740	5 mm	3/16" x 3"	5 x 75	12/240	1.0/20.1
47-741	5 mm	3/16" x 4"	5 x 100	12/240	1.0/21.0
47-742	6 mm	1/4" x 4"	6 x 100	12/120	1.2/12.4
47-743	6 mm	1/4" x 6"	6 x 150	12/120	1.3/14.0
47-744	8 mm	5/16" x 6"	8 x 150	12/120	1.8/18.0
47-745	8 mm	5/16" x 8"	8 x 200	12/96	1.8/19.5
47-746	10 mm	3/8" x 8"	10 x 200	6/60	2.1/21.0
47-747	10 mm	3/8" x 10"	10 x 250	6/60	2.3/23.0

⊖ Slotted

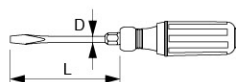

- ** Crossman platinum shaft; hardened but high ductility.
- ** Handle is made of cushion-grip material for more powerful drive.
- ** Ideal for construction or furnishing work etc.



Screwdrivers **DIAMOND TIP®**

■ **Diamond Tip® Advanced Cushion Grip/Acetate Handle Screwdriver - Phillips w/Hex Bolster**

Item No.	Pt. Size	Size (DxL)			
		inch	mm		
47-780	PH1	3/16" x 3"	5 x 75	12/240	1.0/20.1
47-781	PH1	3/16" x 4"	5 x 100	12/240	1.0/21.0
47-782	PH2	1/4" x 4"	6 x 100	12/120	1.2/12.4
47-783	PH2	1/4" x 6"	6 x 150	12/120	1.3/14.0
47-784	PH3	5/16" x 6"	8 x 150	12/120	1.8/18.0
47-785	PH3	5/16" x 8"	8 x 200	12/96	1.8/19.5
47-786	PH4	3/8" x 8"	10 x 200	6/60	2.1/21.0
47-787	PH4	3/8" x 10"	10 x 250	6/60	2.3/23.0

Phillips

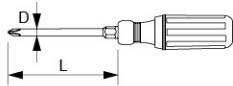

- ** Crossman platinum shaft; hardened but high ductility.
- ** Handle is made of cushion-grip material for more powerful drive.
- ** Ideal for construction or furnishing work etc.

■ **Diamond Tip® Sheffield Acetate Handle Screwdrivers - Slotted w/Hex Bolster**

Item No.	Pt. Size	Size (DxL)			
		inch	mm		
47-309	5 mm	3/16" x 3"	5 x 75	12/300	0.8/20.0
47-419	5 mm	3/16" x 4"	5 x 100	12/300	0.9/22.1
47-315	6 mm	1/4" x 4"	6 x 100	12/240	1.2/23.0
47-316	6 mm	1/4" x 6"	6 x 150	12/240	1.2/24.0
47-319	8 mm	5/16" x 6"	8 x 150	6/120	0.7/13.5
47-320	8 mm	5/16" x 8"	8 x 200	6/120	0.7/14.5
47-322	10 mm	3/8" x 8"	10 x 200	6/60	2.4/24.0
47-328	10 mm	3/8" x 10"	10 x 250	6/48	2.6/20.8

Slotted

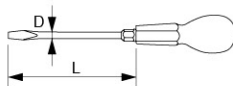

■ **Diamond Tip® Sheffield Acetate Handle Screwdrivers - Phillips w/Hex Bolster**

Item No.	Pt. Size	Size (DxL)			
		inch	mm		
47-339	PH1	3/16" x 3"	5 x 75	12/300	0.8/20.0
47-429	PH1	3/16" x 4"	5 x 100	12/300	0.9/22.1
47-345	PH2	1/4" x 4"	6 x 100	12/240	1.2/23.0
47-346	PH2	1/4" x 6"	6 x 150	12/240	1.2/24.0
47-349	PH3	5/16" x 6"	8 x 150	6/120	0.7/13.5
47-350	PH3	5/16" x 8"	8 x 200	6/120	0.7/14.5
47-352	PH4	3/8" x 8"	10 x 200	6/60	2.4/24.0
47-358	PH4	3/8" x 10"	10 x 250	6/48	2.6/20.8

Phillips

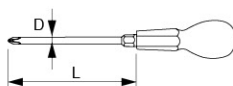

- ** Crossman platinum shaft; hardened but high ductility.
- ** Handle is made of eco-friendly acetate w/fiber.
- ** Ideal for mechanical machine, mining or engineering sites etc.

Hex Key Wrenches **DIAMOND TIP[®]**



10X LONGER LIFE





Diamond Tip is always there





** Powerful gripping force derived from our crystalline diamond grit that are constantly extruding & exposed.

■ **Diamond Tip[®] Ball-Speed[®] Hex Key Wrenches - Long Length (Metric)**

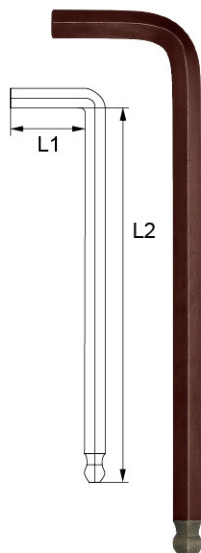
Item No.	Size	L1	L2		 kgs
65-404	1.5	14	77	200/2,000	0.35/3.76
65-405	2.0	16	83	200/2,000	0.55/5.86
65-406	2.5	18	90	200/2,000	0.97/10.07
65-407	3.0	20	98	100/1,000	0.75/7.76
65-408	4.0	25	106	50/500	0.72/7.51
65-410	5.0	28	118	50/500	1.27/13.07
65-412	6.0	32	137	25/250	1.06/10.99
65-414	8.0	36	156	20/200	1.71/17.47
65-416	10.0	40	170	12/120	1.77/18.11



■ **Diamond Tip[®] Ball-Speed[®] Hex Key Wrenches - Long Length (SAE)**

Item No.	Size	L1	L2		 kgs
65-431	1/16	14	77	200/2,000	0.35/3.76
65-432	5/64	16	82	200/2,000	0.55/5.86
65-433	3/32	18	88	200/2,000	0.97/10.07
65-435	1/8	20	96	100/1,000	0.75/7.76
65-437	5/32	25	105	50/500	0.72/7.51
65-438	3/16	28	114	50/500	1.27/13.07
65-440	1/4	32	135	25/250	1.06/10.99
65-441	5/16	36	156	20/200	1.71/17.47
65-442	3/8	40	170	20/200	1.77/18.11

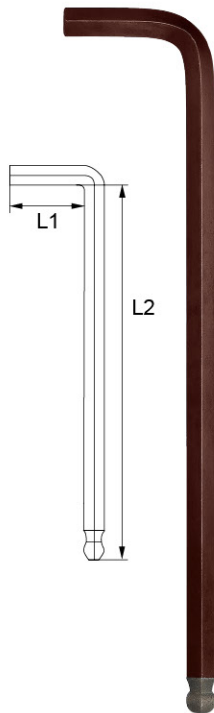
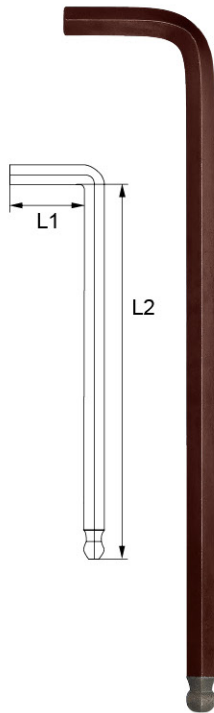

Hex Key Wrenches **DIAMOND TIP®**

■ Diamond Tip® Ball-Speed® Hex Key Wrenches - Extra Long Length (Metric)

Item No.	Size	L1	L2		kgs
65-501	1.5	14	90	200/2,000	0.35/3.76
65-502	2.0	16	100	200/2,000	0.67/7.07
65-503	2.5	18	112	200/2,000	1.17/12.07
65-504	3.0	20	126	100/1,000	0.92/9.57
65-505	4.0	25	140	50/500	0.92/9.57
65-506	5.0	28	160	50/500	1.67/17.07
65-508	6.0	32	180	25/250	1.37/14.07
65-510	8.0	36	200	20/200	2.09/21.35
65-511	10.0	40	224	12/72	2.3/14.44

■ Diamond Tip® Ball-Speed® Hex Key Wrenches - Extra Long Length (SAE)

Item No.	Size	L1	L2		kgs
65-531	1/16	14	90	200/2,000	0.35/3.76
65-532	5/64	16	100	200/2,000	0.67/7.07
65-533	3/32	18	112	200/2,000	1.17/12.07
65-534	1/8	20	126	100/1,000	0.92/9.57
65-535	5/32	25	140	50/500	0.92/9.57
65-536	3/16	28	160	50/500	1.67/17.07
65-538	1/4	32	180	25/250	1.37/14.07
65-539	5/16	36	200	20/200	2.09/21.35
65-540	3/8	40	224	12/72	2.3/14.44



Hex Key Wrenches **DIAMOND TIP®**

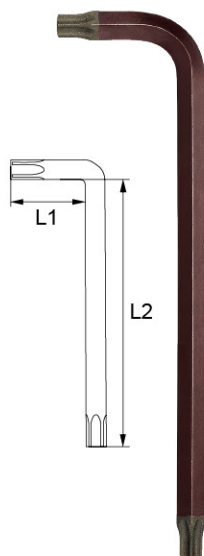

■ Diamond Tip® TORX® Tamper Proof Key Wrenches - Long Length

Item No.	Size	L1	L2		kgs
65-601	T10	14	77	200/2,000	1.05/10.76
65-602	T15	16	83	200/2,000	1.2/13.0
65-603	T20	18	90	200/2,000	2.27/23.07
65-604	T25	20	98	100/1,000	1.3/13.5
65-605	T27	25	106	50/500	1.1/11.5
65-606	T30	28	118	50/500	1.32/13.57
65-607	T40	32	137	25/250	1.12/11.57
65-608	T45	36	156	20/200	1.71/17.47
65-609	T50	40	170	12/120	1.75/17.87

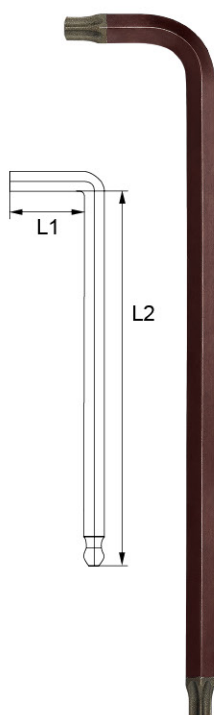

■ Diamond Tip® TORX® Tamper Proof Key Wrenches - Extra Long Length

Item No.	Size	L1	L2		kgs
65-631	T10	14	90	200/2,000	1.27/13.0
65-632	T15	16	100	200/2,000	1.47/15.07
65-633	T20	18	112	200/2,000	2.67/27.0
65-634	T25	20	126	100/1,000	1.57/16.0
65-635	T27	25	140	50/500	1.4/15.0
65-636	T30	28	160	50/500	1.62/16.57
65-637	T40	32	180	25/250	1.3/14.0
65-638	T45	36	200	20/200	2.0/21.0
65-639	T50	40	224	12/120	2.3/23.62



10X LONGER LIFE

5X MORE GRIPPING POWER

Diamond Tip is always there



** Powerful gripping force derived from our crystalline diamond grit that are constantly extruding & exposed.

Diamond Tip[®] Aviation Snip (Left cutting)



Item No.	Size		
49-921	10"	12	48

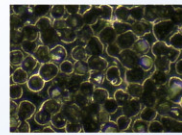

** Microscope shows well-dispersed microcrystalline diamond In array all over the tip surface.

Diamond Tip[®] Aviation Snip (Right cutting)



Item No.	Size		
49-922	10"	12	48

Diamond Tip[®] Aviation Snip (Straight cutting)



Item No.	Size		
49-923	10"	12	48

Diamond layer on the blade

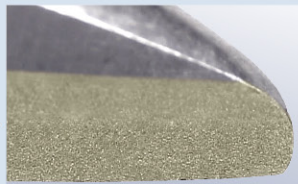

◆ Cutting edge prior to cutting.

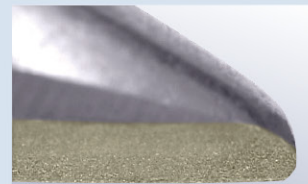

◆ Cutting edge still looks new even repeatedly cutting metal sheet 1.2mm in thickness.



CROSSMAN[®]
PROFESSIONAL